

Instructions for Assembling the Sweet Sorter. (SS/05-06)

You will need the following tools/equipment.

- Soldering iron, solder, safety goggles.
- Small cross-head screwdriver, small pliers/spanners.
- Wire cutters/strippers.

Before you start.

Check that you have all the parts listed below. (Diagrams not to scale)

All the acrylic pieces have a protective covering that must be removed before attempting to assemble any pieces.

The colour sensor needs assembling using the separate instructions included.

The sorter is designed to sort flat, round sweets. Smarties™ and M&M's™ have been used as the default sweets. Different components/settings are required for each, and these are noted within the instructions.

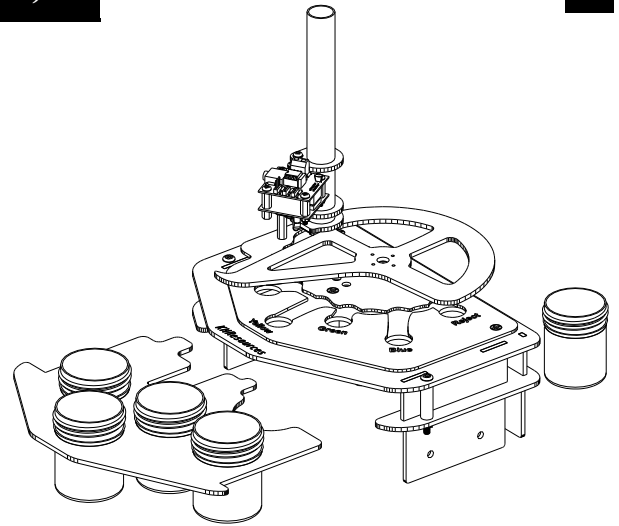

Components included in this kit.

Servo Arm.

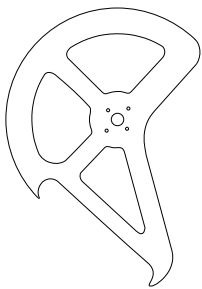

Sorting Plate.

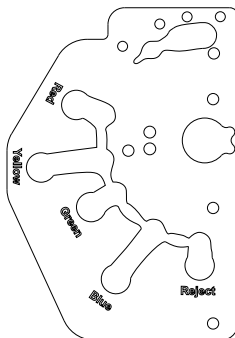

Top Plate.

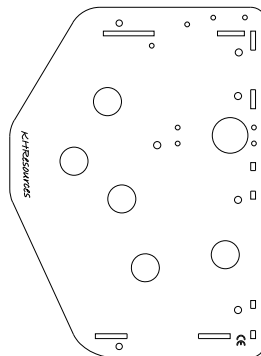

Container Plate.

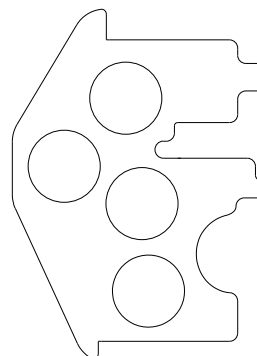

Mid Plate.

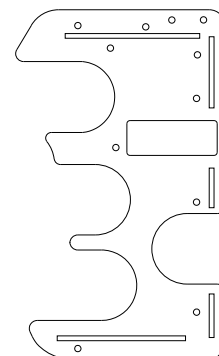

Sweet Tube.



Side leg supports.

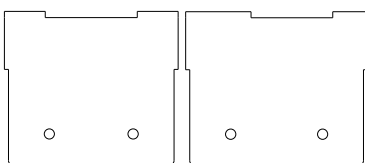

Rear leg supports.

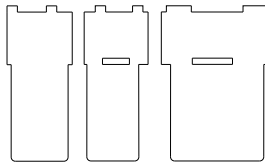

Upper & Middle Tube supports.

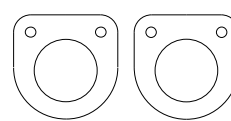

Base plates.

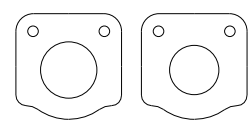

Grey spacer (x 7)

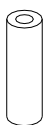

3x6 mm threaded post. (x8)

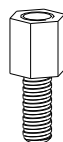

You should also find:

- 5 - 4x40 mm Pan-head screws.
- 2 - 4x40 mm Countersunk screws.
- 10 - 3x6 mm Pan-head screws.
- 4 - N0.2x3/16 Self tapping screws.
- 2 - Velcro™ Loop pads.

- 7 - 4 mm flat washers.
- 7 - 4 mm locking washers.
- 7 - 4 mm nuts.
- 20 - 3 mm flat washers.
- 4 - 3 mm locking washers.
- 6 - 3 mm nuts.

Servo & servo horn.

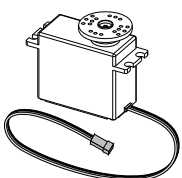

Colour sensor kit.

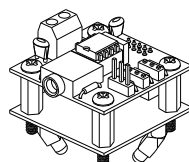

The above components are in *addition* to those found in the sensor kit.

Attaching the servo to the top plate.

1.

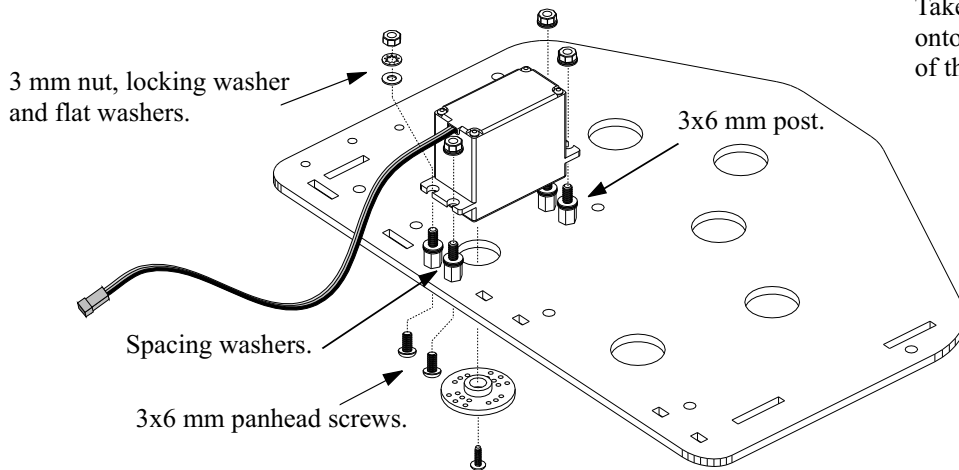

Take 4 of the 3x6 mm threaded posts, screw them onto the top plate, then use washers to set the height of the servo for Smarties™ or M&M's™.

For Smarties™ use 3 washers between each post & servo.
For M&M's™ use just one washer.

Attaching the legs to the top plate.

2.

Keep the top plate upside down and slot the side and rear legs into place.

Note: each leg will only fit into its correct slot. If it does not fit properly it is in the wrong slot.

Lower the middle plate over the legs as shown, then turn over to attach the screws and spacers.

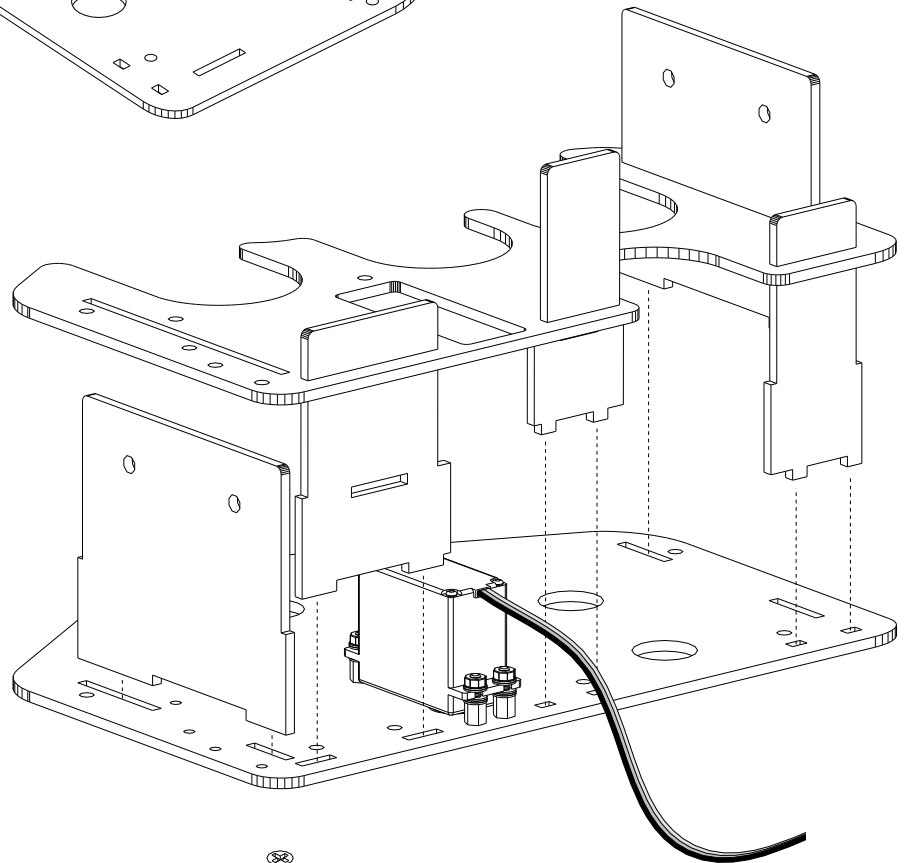

Securing the chassis with screws & spacers.

3.

4x40 mm pan-head screw.

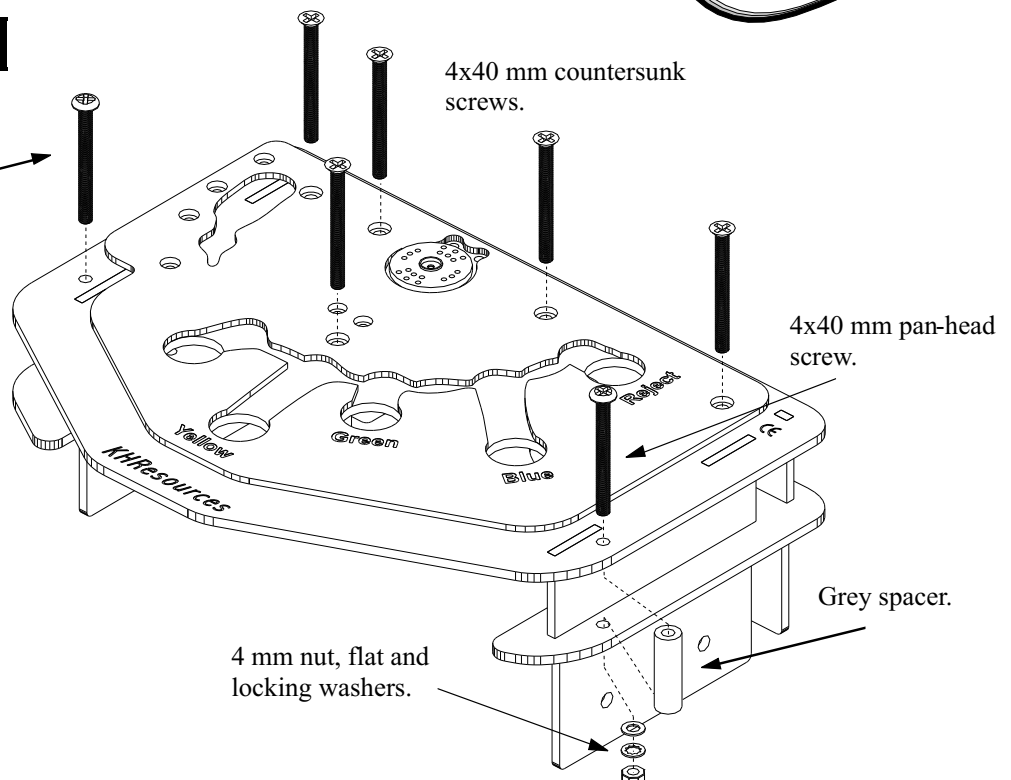

The sorting plate needs to be placed onto the top plate before the countersunk screws can be added. These screws hold the Sorting plate in place.

Each of the 7 screws should be fitted with a grey spacer, as the screws are passed through the chassis.

Assembling the tube holder.

4.

Two base plates have been supplied; one with a 14 mm Ø centre hole, the second with a 16 mm Ø centre.

If sorting Smarties™ use the 16 mm plate, for M&M's™ use the 14 mm plate.

Each plate needs 2 strips of Velcro™ loops as shown, this holds the sweets in place ready for the arm to select them. Cut two strips from the Velcro™ supplied.

Base plate shown upside-down.

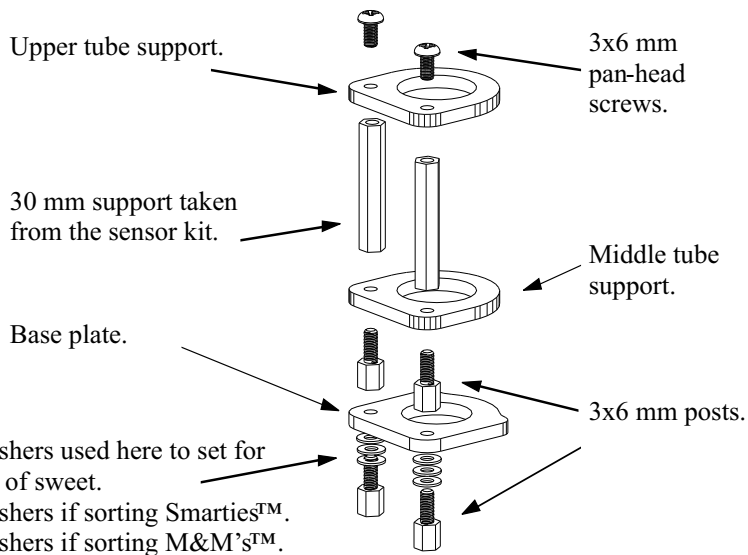
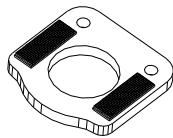

Completing the colour sensor.

5.

Assemble the PICAXE-08M servo driver and colour sensor boards according to the instructions provided in the colour sensor kit and then add the threaded posts as shown here.

3x6 mm threaded posts.

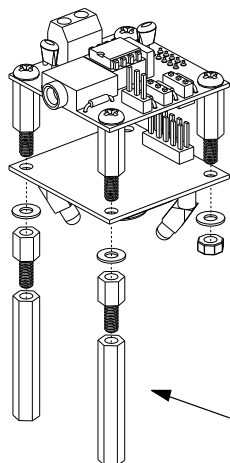

3x12 mm posts from sensor kit.

3 mm nuts & washers.

3x30 mm threaded posts from sensor kit.

Sweet tube should drop down through the upper & middle supports and rest on the base plate.

Fitting the colour sensor, tube holder and sorting arm.

6.

No.2x3/16 self tapping screws used to secure sorting arm onto servo horn.

Note: Do not over tighten screws as only a short length of screw protrudes into the horn.

The position of the servo horn will need to be adjusted to give a full sweep of the sorting arm. Point (a) should be able to sweep beyond the 'reject' hole. Point (b) should be able to come back as far as the 1st sensor support.

Point (a) should be able to sweep beyond the 'reject' hole. Point (b) should be able to come back as far as the 1st sensor support.

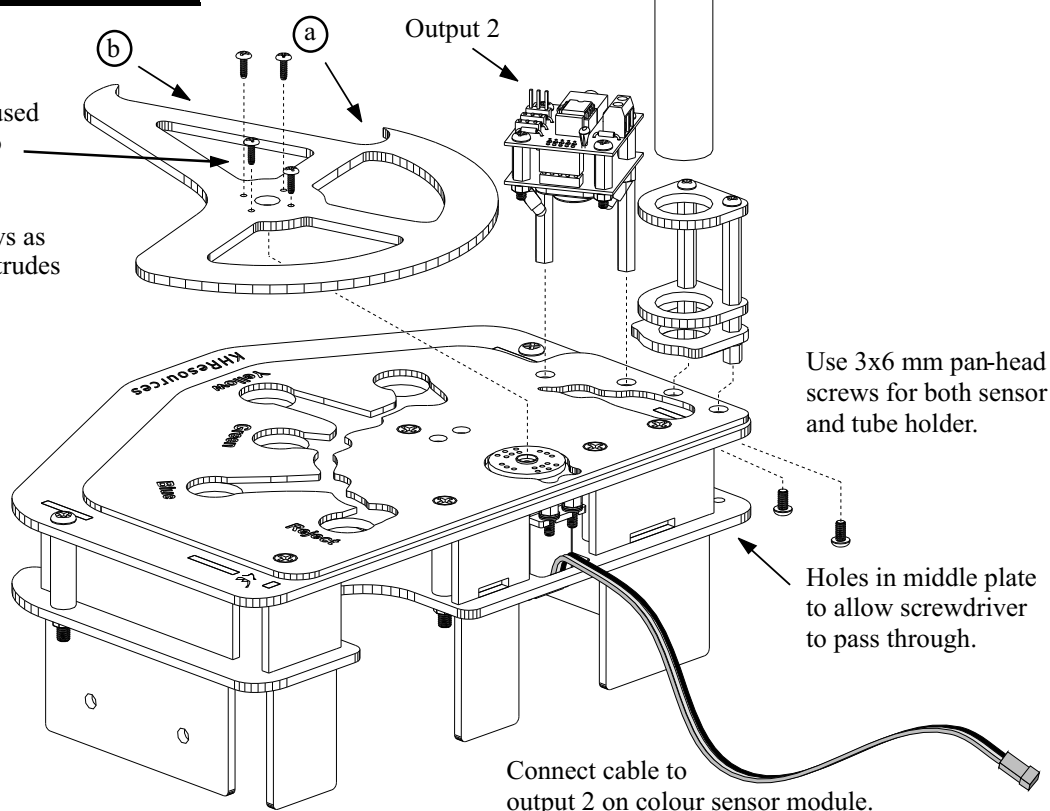

The sensor can be powered from the 4xAA battery holder supplied, or from a 6 volt power supply (not supplied).

The power needs to be on when downloading/connecting to a PC.

A basic program for the sweet sorter can be down loaded from www.picaxe.co.uk, or found on the colour sensor data sheet.

Within your program it is important to set the positions of each coloured drop-hole together with the sweet tube position and the sensor position. Some rough positions are given but these will need amending to suit the servo and the position of the servo horn.

The two white LED's should be positioned to give a single 'oval' area of light on top of the sweet to be read, if you have a 'figure of 8' shape you will not reflect enough light back up to the sensor.

Both Smarties™ and M&M's™ reflect different amounts of light, so two programs will have to be set up to work with each type of sweet.

When loading the sweets into the tube, ensure that they are sat on top of each other and not side by side. If not they will jam as they get to the base plate.

On starting up the sorting arm should rotate around until under the sweet tube as shown, allowing one sweet to drop. After a short pause it should vibrate to ensure the sweet has actually dropped, then move the sweet under the sensor and back off slightly. The LED's will flash, the sensor reads the colour of the sweet and then the sorting arm should rotate around to the correct colour position. The arm will now return, pushing the sweet into its chosen pot.

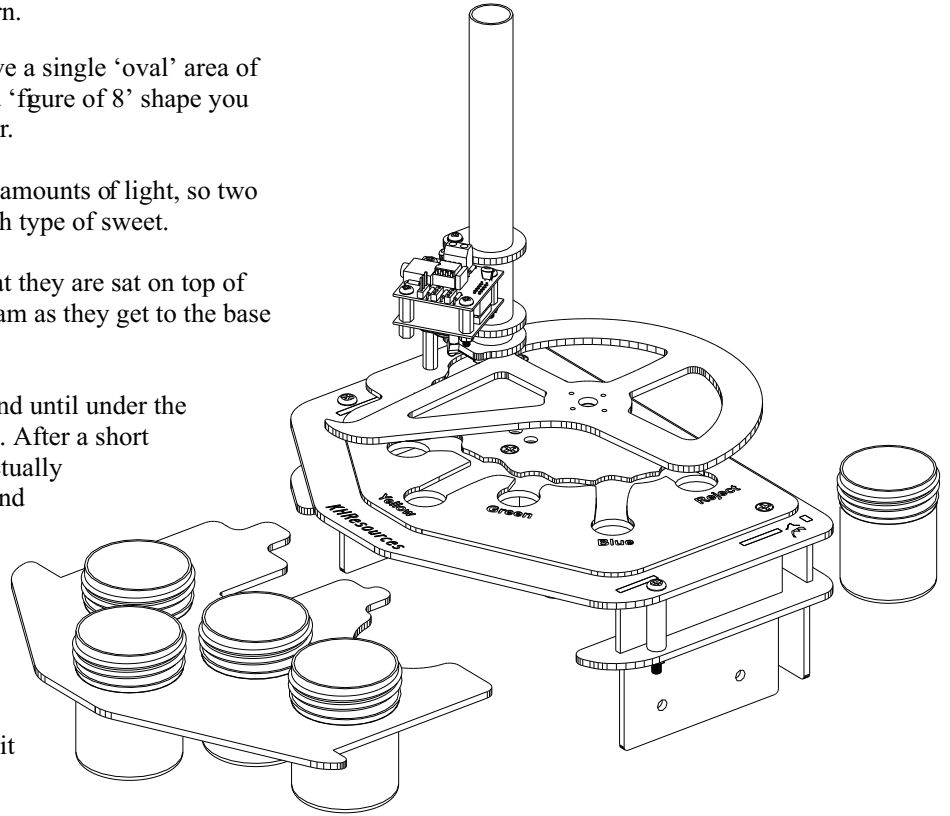

CAUTION: Keep fingers away from the arm as it sweeps around, to avoid injury.

We respect all the Trademarks used within this document and do not intend to infer that this product is in any way endorsed by the Trademark owners.



REPRODUCED WITH PERMISSION FROM THE BRITISH BATTERY MANUFACTURERS ASSOCIATION.

ALWAYS	ALWAYS	NEVER	ALWAYS
Store unused batteries in their packaging and away from metal objects which may cause a short-circuit.	Remove dead batteries from equipment and all batteries from equipment you know you are not going to use for a long time.	Never dispose of batteries in fire as this may cause them to explode. Please put dead batteries in with the normal household waste.	Take care to fit your batteries correctly, observing the plus and minus marks on the battery and appliance.
NEVER	ALWAYS	ALWAYS	ALWAYS
Never attempt to recharge ordinary batteries, either in a charger or by applying heat to them. There are special rechargeable batteries which are marked as such.	Supervise children if they are replacing batteries themselves in order to ensure these guidelines are followed.	Make sure battery compartments are secure.	Replace the whole set of batteries at one time, taking care not to mix old and new batteries or batteries of different types.

PICAXE™ name used with permission of :
 Revolution Education Ltd.
www.picaxe.co.uk

PICAXE™ programming/editing software available free from the above website.

For further information on other products in our range, contact:
 KHResources Ltd. www.khresources.co.uk
 P.O. Box. 161 email: khresourcesltd@onetel.com
 Stockport Cheshire SK12 1WE



```

'AXE112 Colour module using PICAXE-08M
'Sorts coloured Smarties(TM) into correct position bin

' This file is saved within the samples folder of the Programming Editor
' software as file <MOD020 Sweet Sorter.bas>

' *****
' Servo Position Constants

' Predefined servo positions - will require editing for your setup!
' These positions need to be found by experimentation

symbol pos_tube = 22      ' tube position
symbol pos_scan = 55     ' scan position

symbol pos_red = 90      ' red bin
symbol pos_green = 136   ' green bin
symbol pos_blue = 167    ' blue bin
symbol pos_yellow = 117  ' yellow bin
symbol pos_reject = 193  ' reject bin

' *****
' PICAXE-08M input/output pins

symbol LED = 0 ' Colour sensor white LEDs   (output 0)
symbol S2 = 1 ' Colour sensor select S2     (output 1)
symbol ser = 2 ' Servo                       (output 2)
symbol CSI = 3 ' Colour sensor pulse        (input 3)
symbol S3 = 4 ' Colour sensor select S3     (output 4)

' *****
' Variables

symbol counter = b0      ' Counters for loops
symbol counter2 = b1
symbol start_pos = b2    ' Servo start position
symbol end_pos = b3      ' Servo end position

symbol red_value = w4    ' Colour sensor red content
symbol blue_value = w5   ' Colour sensor blue content
symbol green_value = w6  ' Colour sensor green content
                          ' Remember w4-w6 uses b8-b13!

' *****
'initialise LED and move servo to tbe tube position

init:  low LED           ' make LED pin an output
        start_pos = pos_tube ' set start position
        servo ser, pos_tube ' move servo
        pause 300        ' delay for servo to move

```

```

' *****
' scan and sort a sweet every 3 seconds

main:
  low ser      ' servo off to save power
  pause 3000   ' wait three seconds

' vibrate sweet out of tube

  for counter2 = 1 to 3
    end_pos = pos_tube + 4
    gosub move
    end_pos = pos_tube
    gosub move_back
  next counter2

' move to scanning position

  end_pos = pos_scan
  gosub move

' scan the colour

  gosub colour

' move to correct bin

  gosub move
  pause 100

' back to start

  end_pos = pos_tube
  gosub move_back

  goto main

' *****
' sub to move servo slowly forwards
' moving one servo step every 18ms
' makes servo move slower than normal

move:
  for counter = start_pos to end_pos
    servo ser, counter
    pause 18
  next counter
  start_pos = end_pos
  return

' *****
' sub to move servo slowly back

move_back:
  for counter = start_pos to end_pos step -1
    servo ser, counter
    pause 18
  next counter
  start_pos = end_pos
  return

```



```

' now identify correct colour using these values

    ' at this point can be any colour

    if blue_value > red_b_min and blue_value < red_b_max then test_red
    'only can be red
    if blue_value > blue_b_min and blue_value < blue_b_max then test_blue
    'only can be blue

    'now either green yellow or reject

    if red_value > yellow_r_min and red_value < yellow_r_max then test_yellow
    'only can be yellow
    if red_value > green_r_min and red_value < green_r_max then test_green
    'only can be green

    ' only reject left so return

is_reject:
    return

' blue
test_blue:
    if red_value < blue_r_min or red_value > blue_r_max then is_reject
    if green_value < blue_g_min or green_value > blue_g_max then is_reject
    'if blue_value < blue_b_min or blue_value > blue_b_max then is_reject
    end_pos = pos_blue
    return

' red
test_red:
    if red_value < red_r_min or red_value > red_r_max then is_reject
    if green_value < red_g_min or green_value > red_g_max then is_reject
    'if blue_value < red_b_min or blue_value > red_b_max then is_reject
    end_pos = pos_red
    return

' green
test_green:
    'if red_value < green_r_min or red_value > green_r_max then is_reject
    if green_value < green_g_min or green_value > green_g_max then is_reject
    if blue_value < green_b_min or blue_value > green_b_max then is_reject
    end_pos = pos_green
    return

' yellow
test_yellow:
    'if red_value < yellow_r_min or red_value > yellow_r_max then is_reject
    if green_value < yellow_g_min or green_value > yellow_g_max then is_reject
    if blue_value < yellow_b_min or blue_value > yellow_b_max then is_reject
    end_pos = pos_yellow
    return

```