

CHI030A PICAXE-18 STANDARD PROJECT BOARD

Introduction

The CHI030A standard board uses a darlington driver IC to provide power to 8 digital (on/off) outputs (PICAXE pins B.0 to B.7). Each output is rated at 500mA. 6 digital (or 4 digital/2analogue) inputs are also available (PICAXE pins C.0 to C.7), all prefitted with a 10k pull down resistor for ease of use.

A high power board is also available (part CHI035A) separately. This uses 4 FETs to provide 4 high power digital outputs (rated at 1.5A each), and the option of a L293D motor driver IC to provide 2 reversible motor outputs, rated at 1A each.

Both boards are supplied ready for immediate use with the PICAXE-18M2 chip. The inputs (portC) are on the left and buffered outputs (portB) are on the right. The direct (non-buffered) portB PICAXE outputs are also available in the centre of the board for connection to logic level devices (e.g. an AXE033 Serial LCD).

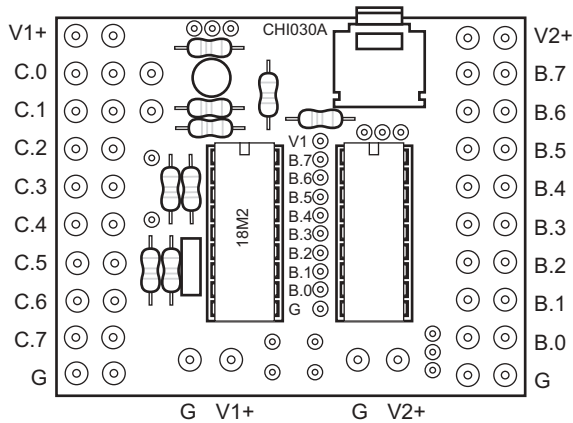

To use the board with an older (now discontinued) 18/18A/18M/18X PICAXE part an extra 1k resistor ***MUST*** be soldered to the board in the 'RST' resistor position. If desired an optional reset switch (part SEN030) may also be fitted in position 'S1'. Note that the current release PICAXE-18M2 does not have a reset pin, so does not require the RST resistor or the reset switch to be fitted.

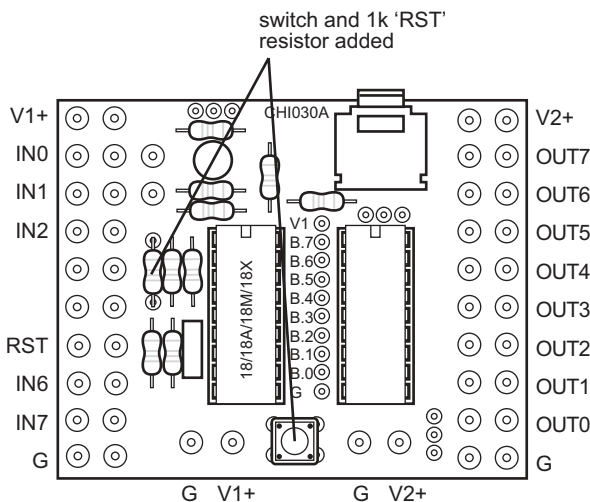

For the full datasheet for this product please see www.rev-ed.co.uk/docs/chi030a.pdf

Circuit Board Preparation

Many Revolution Education project boards including the CHI030A are supplied with a protective ‘peelable’ layer over the user solder pads on the rear of the PCB. This layer may be red or green in colour and can be easily peeled off with your finger nail before soldering.



This peelable layer protects the user solderable pads during manufacture and storage, to keep the pads clean and grease free.

Note also that the solder pads on the PCBs may now appear as a dull white “milky” colour, not “shiny silver” as in the past. This is due to the more “environmentally friendly” lead-free chemicals now used for plating RoHS compliant PCBs.

This is not a fault and the pad can still be hand soldered just as easily as the older style ‘shiny’ solder pads. No cleaning is generally required prior to soldering.

Project Board Power Supply

The CHI030A project board can be powered in 3 separate different ways:

- Via a single 4.5V battery pack for both PICAXE & outputs
- Via two separate battery packs for PICAXE and outputs
- Via a higher voltage battery pack, with 5V regulator fitted for the PICAXE

Single Battery Pack.

The board requires a single 3-5V power supply to operate, a 4.5V supply is recommended via a 3xAA cell battery pack, connected to the V2+ (PWR) terminal connections. This pack will then power both the microcontroller and the output devices. The black wire is connected to the G (ground) connection and the red wire to the V2+ connection.

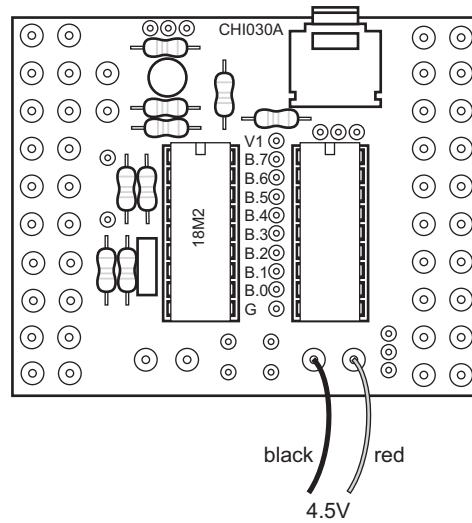

Dual Battery Pack.

If a higher voltage (e.g. 12V) is required to drive the outputs, two separate power supplies may be used. In this case the second power supply only powers the output devices. The 4.5V power supply is connected to V1+ (PIC) and the second 12V power supply is connected to V2+ (PWR). When using two power supplies the wire link (resistor with single black band) shown **MUST** be cut off the board to separate the two supplies.

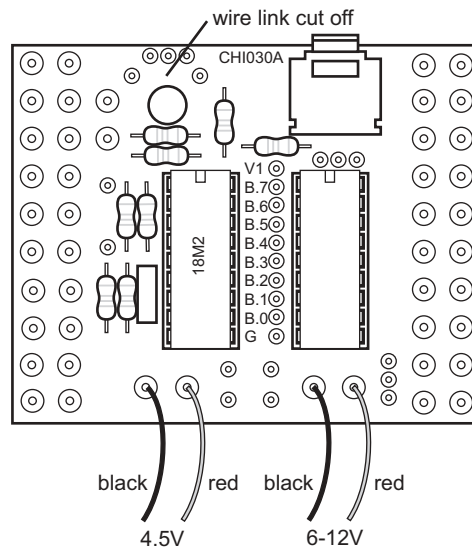

Single Battery Pack with Regulator

If a higher voltage (e.g. 12V) is required to drive the outputs, one power supply plus a 78L05 voltage regulator may be used. In this case the power supply powers the output devices directly, and the voltage regulator provides a 5V supply to the PICAXE microcontroller. The power supply is connected to the V2+ (PWR) terminal connections. When using this system the wire link (resistor with single black band) **MUST** be cut off the board to separate the two supplies, then a 78L05 voltage regulator must be fitted as shown.

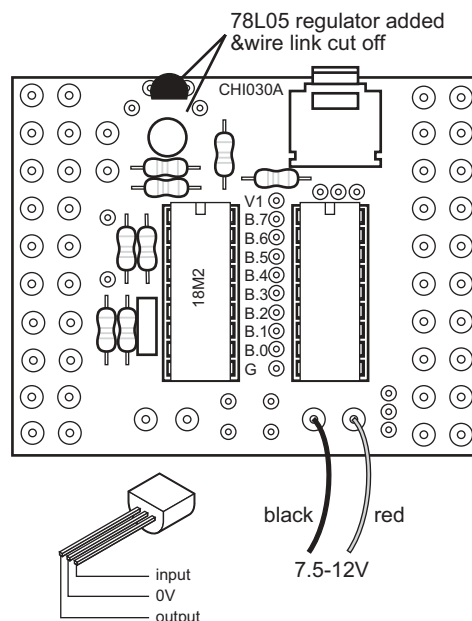

Output Devices

Output devices are connected between the pairs of holes on the pcb (pin and V2+) as shown below.

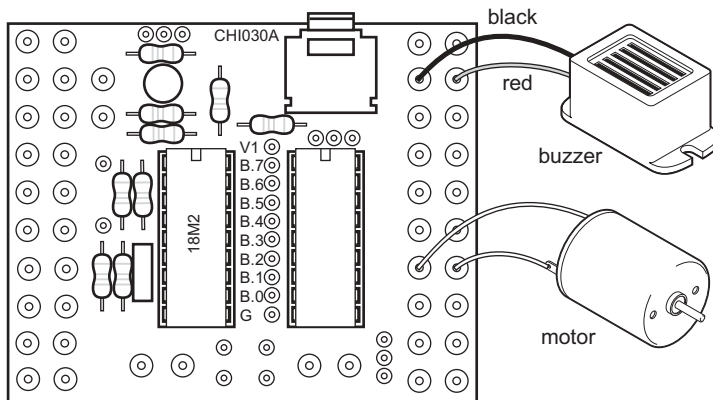

Note that motors should be suppressed by soldering a 220nF polyester capacitor (part CAP002) across the motor terminals to prevent electrical noise affecting the circuit.

On the standard project board only on/off control of the motor is possible. It cannot be 'reversed', for this type of movement the CH1035A board is required instead.

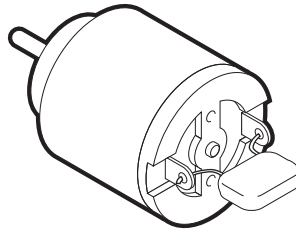

Input Devices

Digital inputs are connected between V1+ and the pin as shown below.

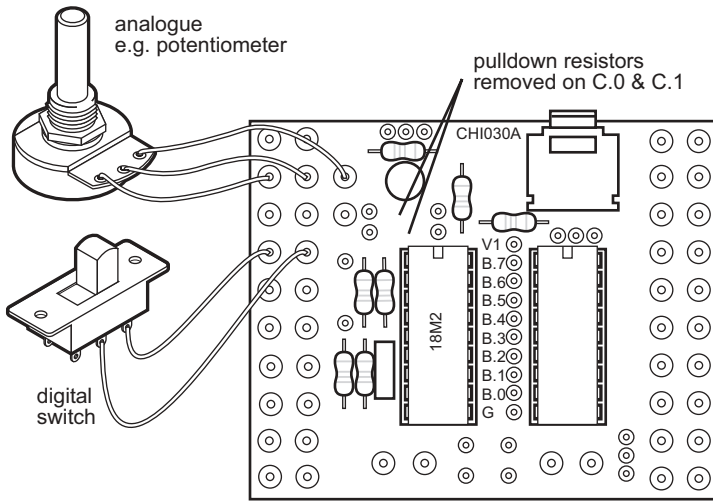

The connections marked C.3 and C.4 should not generally be used with the PICAXE system. These are used by the PICAXE chip as the ‘serial in’ and ‘serial out’ PC download connection.

All inputs are provided with a 10k pull down resistor pre fitted to the board.

However the board is also configured to allow use of inputs C.0 and C.1 as analogue inputs. Some analogue sensors, such as a potentiometer, will require the on-board 10k resistor to be cut off from the positions marked R8 (upper resistor, input C.0) and R7 (lower resistor, input C.1) as shown above.

Connecting to the Project Boards

Inputs and outputs may be soldered via wires directly to the board. Alternately you may wish to purchase screw terminal blocks (5mm pitch) and solder these to the boards as shown below. This allows wires to be temporarily connected via the screw terminals. For one board 6 sets of part CON005 (2x2 pole connector) are required.

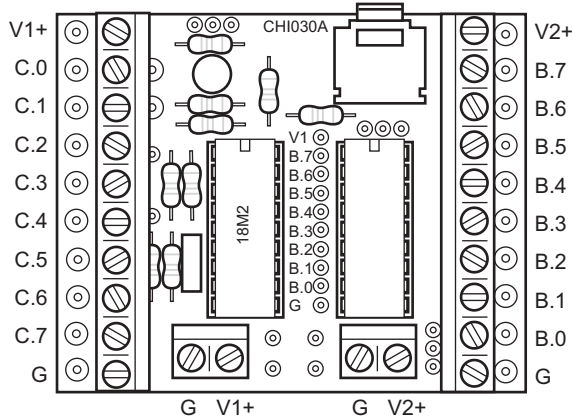

Note that when using terminal blocks it is necessary to ‘share’ the V2+ connector with all output pins and to ‘share’ the V1+ connector with all inputs. Remember that with the darlington driver output buffer the output devices are connected between V2+ and the output (NOT output to 0V). Like wise the inputs are connected between V1+ and the input.

