

BOT115 PICAXE CREATE

The PICAXE Create System is based around a PICAXE-18M2 motherboard and various input/output modules which connect to the motherboard using patented 'micro-bric' connectors. These connectors, tightened and loosened with the supplied Allen key, are used to connect the various input/output modules to the 13 available motherboard connectors. When the bolts are tightened the plastic bricks create both a strong mechanical and electrical joint, so that various circuit configurations can easily be built and adjusted by just swapping modules around - no soldering required to reconfigure the system!

The starter pack contains:

- PICAXE-18M2 Motherboard
- Microbric connectors and Allen Key

- Touch sensor input
- Push switch input
- Slide switch input
- DS18B20 Temperature Sensor input
- LDR input
- Infra-red Input
- Terminal block generic connector

- Infra-red output
- Piezo output
- LED output
- Darlington transistor output (e.g. for buzzer)
- L293D reversible motor driver output
- Servo Output connector
(purchase GBX013 servo separately)
- SRF005 Ultrasonic Range Finder connector
(purchase SRF005 sensor separately)
- Serial LCD connector
(purchase AXE133 or AXE133Y Serial LCD separately)

The motherboard is supplied fully assembled, the input/output modules require soldering before first use. Once initially assembled (by the teacher) the students do not need to do any soldering to assemble, disassemble or reconfigure the system.

All modules are also compatible with the BOT120 Microrobot.

PICAXE Programming System

The 'brain' of PICAXE Create is a powerful PICAXE-18M2 micro-controller that can be reprogrammed by the end user. Therefore the motherboard can be easily reconfigured and then updated with new control programs as required. For further details about using the PICAXE system please see the PICAXE manuals, which are available as a free download from www.picaxe.com

This manual includes side by side examples of both 'PICAXE BASIC' and 'Logicator flowchart' programs. Either can be used to program the PICAXE Create system.

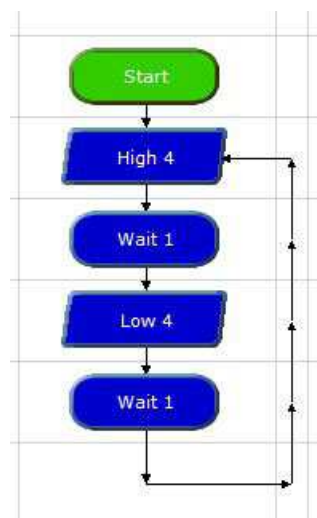
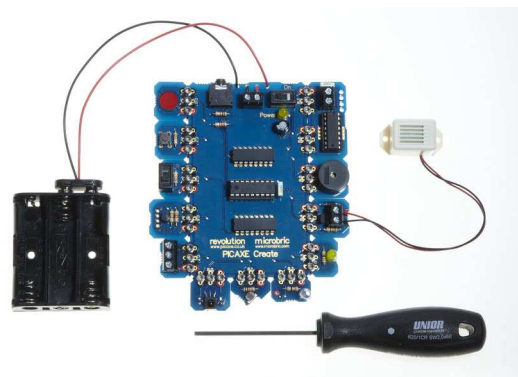

Contents

PICAXE Programming System	1
BOT115 PICAXE Create Contents List	3
PICAXE Create Power Supply	4
The Microbric Connector	4
Programming Software	5
Programming Cable	5
Download Hard Reset	6
PICAXE-18M2 Pin Connections	6
Assembly Guide - BOT116 Outputs PCB Panel	7
Assembly Guide - BOT123 Servo Outputs Pack	9
Assembly Guide - BOT117 Inputs PCB Panel	10
Assembly Guide - BOT121 Sensors PCB Panel	12
BOT127 (optional) Line Tracker / LED Upgrade Pack	14
TVR010A (optional) Infra-red TV Style Remote	15
Programming Example 1 - LED Module	16
Programming Example 2 - Push Button Switch	17
Programming Example 3 - Piezo Sounder	18
Programming Example 4 - Motors	19
Programming Example 5 - Infra-red Receiver	22
Programming Example 6 - Infra-red Transmitter	23
Programming Example 7 - LDR Light Sensor	24
Programming Example 8 - (optional) SRF005 Ultrasonic	25
Programming Example 9 - Servo	26
Appendix 1 - Making your own sensors	27
Appendix 2 - BOT115 Motherboard Schematic	28
Appendix 3 - BOT116 Output Modules Schematic	29
Appendix 4 - BOT117 Input Modules Schematic	30
Appendix 5 - BOT121 Sensors Pack Schematic	31
Appendix 6 - BOT123 Servo Pack Schematic	32
Appendix 7 - Copyright and Trademarks	33
BOT120 Microbot - the robot version motherboard!	33

BOT115 PICAXE Create Contents List

Qty	Description	Replacement order code
1	PICAXE Create Motherboard	BOT115
1	Hex screwdriver	TOO063
1	Battery Clip	BAT016
1	Battery Holder	BAT013
40	M2 hex head bolts	BOT125
40	M2 domed nuts	BOT125
13	brics	BOT125
<i>Input / Output Components</i>		
1	Outputs PCB Panel	BOT116
1	Inputs PCB Panel	BOT117
1	Sensor PCB Panel	BOT121
1	Servo PCB Panel	BOT123
1	100nF capacitor	CAP001
1	4 way terminal block	CON006
1	3 way terminal block	CON005
1	10 way header	CON037
1	5 way socket	CON041
2	Infrared LED	LED021
1	Infrared Sensor	LED020
1	Yellow LED	LED003
1	1N4001 Diode	RES041
1	BCX38C Transistor	TRT002
1	DS18B20 Temperature Sensor	ICO011
1	Miniature LDR	SEN002
1	Miniature Switch	SEN030
1	Minatrure Slide Switch	SEN039
1	PCB Piezo	SPE001
3	Resistor 33	RES-33R
1	Resistor 100	RES-100R
4	Resistor 220	RES-220R
1	Resistor 330	RES-330R
1	Resistor 4k7	RES-4k7
4	Resistor 10k	RES-10k
1	16 pin IC Socket	ICH016
1	L293D motor Driver	ICO030
1	Buzzer	SPE005
1	LCD Cable	DAG002
1	Servo Cable	DAG001

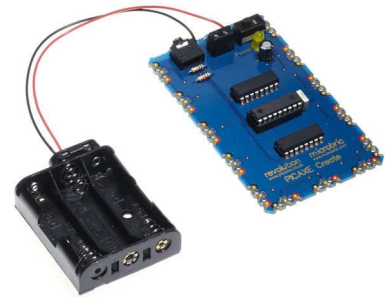

The full assembly instructions and program examples are found in the manual which is a free download from:

<http://www.picaxe.com/docs/bot115.pdf>

PICAXE Create Power Supply

The motherboard is designed to run at 4.5V from 3 x AA size batteries (not supplied). Good quality alkaline batteries are recommended. Always ensure the batteries are connected the correct way around and do not mix new and old, or different types, of batteries together.

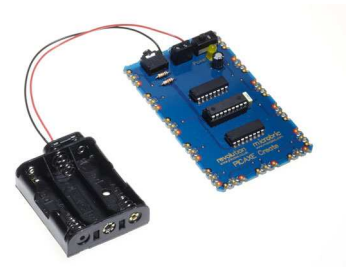

Alternately a regulated 5V DC supply may be used.

If the motherboard fails to operate or works erratically try replacing the batteries. Please dispose of old batteries by taking to a recycling centre.

The Microbric Connector

The motherboard is delivered as a pre-assembled panel, whilst the input/output modules are a set of self-assembly mechanical parts.

A unique aspect of the Create system is that, once the modules have been initially assembled, all reconfiguration of the system can be completed without requiring a soldering iron or other tools apart from an Allen key. All parts of the Create starter pack either bolt or clip together so can be quickly and easily connected, rearranged, or removed as required.

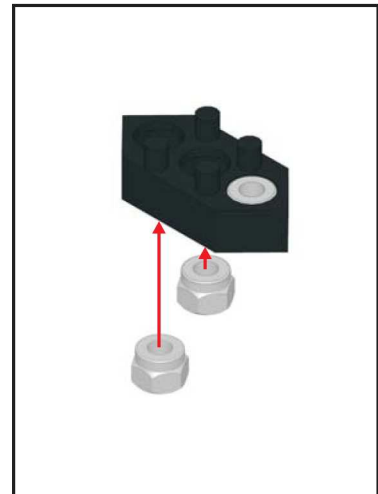

The circuit boards are connected to each other using a patented plastic 'microbric' system. The bric has two purposes, firstly it physically holds the modules together and secondly it provides electrical connection between the modules.

Each bric has three holes into which nuts should be inserted to form a complete bric assembly



Each bric has four locating posts which mount with corresponding holes in the circuit board modules; two posts go into one board and two into the other.

Note that the posts only allow the bric to be connected in one way. When correctly oriented the connecting bric will fit flush to the circuit board. If incorrectly fitted the connecting bric will be angled to the circuit board; in this case remove the connecting bric, rotate it through 180 degrees and then refit.

When aligned correctly, bolts are then used to clamp the two modules together and to form electrical contact from one board to the other.



Download Hard Reset

If your PICAXE-18M2 is busy doing something such as waiting for an IR Remote Control key press it may not notice you are attempting to perform a new download and the download may subsequently fail.

If this happens it is necessary to perform what is known as a 'Hard Reset'.

A Hard Reset is performed by turning your boards power off using the slide switch on the motherboard, starting the download, and then turning the power back on. As the PICAXE-18M2 wakes-up it will always check for a download request and allow the new program to be downloaded, regardless of the program in memory.

PICAXE-18M2 Pin Connections

All circuit board modules are connected via the connector bric; bolting the bric into place completes the electrical connection from one board to the other.

There are 13 positions on the motherboard to which the bric can be connected. Each position is connected to a particular PICAXE-18M2 pin.

In order to control your system you need to interact with its hardware via programming the appropriate PICAXE-18M2 pins.

Note that the 'Logicator for PICAXE' flowcharting software uses a slightly different pin naming system than the BASIC language used by Programming Editor / AXEpad. In Logicator the portB pins are simply called 'outputs' and the port C pins are simply called 'inputs'.

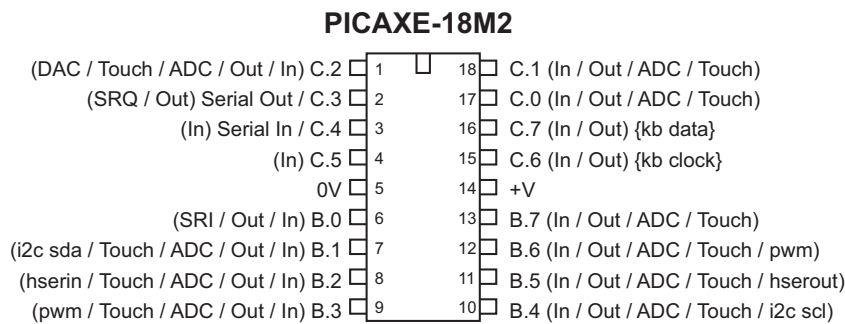

Assembly Guide - BOT116 Outputs PCB Panel

Qty	Description	Replacement order code
1	<i>PCB panel containing:</i>	
	Piezo Output	BOT116
	Motor Driver	BOT116
	Transistor Driver	BOT116
	LED Output	BOT116
1	100nF capacitor	CAP001
1	4 way terminal block	CON006
1	Yellow LED	LED003
1	1N4001 Diode	RES041
1	BCX38C Transistor	TRT002
1	PCB Piezo	SPE001
1	Resistor 33	RES-33R
1	Resistor 100	RES-100R
1	16 pin IC Socket	ICH016
1	L293D motor Driver	ICO030
1	Buzzer	SPE005

The circuit boards of the BOT116 Outputs Pack require a small number of components to be fitted and a small amount of simple soldering. All components required are supplied.

Assembly Instructions:

Carefully remove all PCBs from the panels by applying a gentle rocking motion to the PCBs until they snap out of the panel. Note that in each case the bottom of the PCB is marked with the gold text label (e.g. Piezo).

Piezo Module

Solder the piezo onto the PCB (either way around) and cut the legs short.



LED Module

Place the 33 resistor (orange orange black gold) over the black text on the board so that the legs come out the solder pads on the bottom of the board. Resistors can be placed either way around. Solder in position and cut the legs short.

Place the long leg of the LED through the 'red' hole on the PCB. Solder in position and cut the legs short.



Transistor Output Module

Place the 100 resistor (brown black brown gold) over the black text on the board so that the legs come out the solder pads on the bottom of the board. Resistors can be placed either way around. Solder in position and cut the legs short.

Place the 1N4001 diode in position, ensuring the grey band marked on the diode lies over the black band marked on the PCB. Solder in position and cut the legs short.

Place the BCX38C transistor in position, ensuring the curved edge is marked as on the PCB (curved side towards the microbric connection points). Solder in position and cut the legs short.

Snap the 4 way connector block in half to create 2x 2 pole connector blocks. Solder in position, ensuring the contacts face out.

If desired, screw the supplied buzzer into the terminal block, ensuring the coloured wires match the coloured markers on the PCB.



Motor Driver Module

Place the 16 pin IC socket on the top of the board (side without text). Solder in position.

Place the 100nF capacitor in position and solder in place.

Place the 2 pole connector blocks. Solder in position, ensuring the contacts face the row of 4 identical holes.

Place the L293D chip inside the 16 pin socket, ensuring pin 1 is nearest to the connector block.

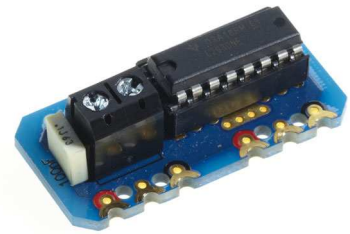

Assembly Guide - BOT123 Servo Outputs Pack

Qty	Description	Replacement order code
1	PCB panel containing: Servo module PCB x 2 SRF005 servo adapter PCB	BOT123 BOT123
3	3 way straight header *	CON035
1	5 way straight socket	CON041
1	220 resistor (red red brown gold)	RES-220
1	100mm servo cable (white wire at edge)	DAG001
1	100mm LCD cable (white wire in middle)	DAG002

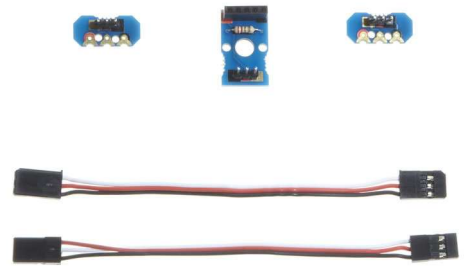

* Please note that the 3 x 3 way headers may sometimes be supplied as 1x10 way header which needs to be simply snapped into 3 x 3 way lengths.

Assembly:

Carefully remove all PCBs from the panels by applying a gentle rocking motion to the PCBs until they snap out of the panel. Note that in each case the bottom of the PCB is marked with the gold text label (e.g. SERVO).



Servo Module PCB

Place the 3 way header onto the top of the PCB, so that the pins come out the bottom. Solder in position.

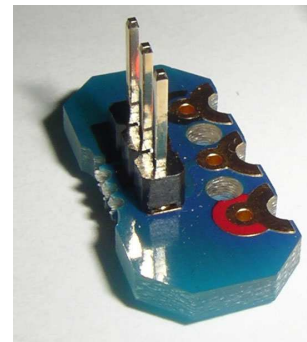

SRF005 Adapter

Place the 220 resistor (red red brown gold) over the black text on the top of the board so that the legs come out the solder pads on the bottom of the board. Resistors can be placed either way around. Solder in position and cut the legs short.

Place the 3 way header onto the top of the PCB, so that the pins come out the bottom. Solder in position.

Place the 5 way socket onto the top of the PCB, so that the pins come out the bottom. Solder in position.

Using a Servo

Purchase a servo and connect it to the servo module.



Using the SRF005 Ultrasonic Range Finder

Purchase an SRF005 range finder and then insert it into the adapter PCB. Connect the adapter PCB to the servo connector via the servo cable.

Using an AXE033 Serial LCD Module

Purchase an AXE033 and then it to the servo connector via the LCD cable. Note the LCD cable has the white wire in the centre at the AXE033 end.



Using an AXE133Y Serial OLED Module

Purchase an AXE133Y and then it to the servo connector via the servo cable. Note the servo cable has the white wire at the edges at both ends.

Assembly Guide - BOT117 Inputs PCB Panel

Qty	Description	Replacement order code
1	<i>PCB panel containing:</i>	
	Temperature Sensor	BOT117
	Push switch (button)	BOT117
	Touch Sensor	BOT117
	Slide Switch	BOT117
	Terminal Block	BOT117
1	3 way terminal block	CON005
1	DS18B20 Temperature Sensor	ICO011
1	Miniature Switch	SEN030
1	Minatrure Slide Switch	SEN039
1	Resistor 4k7	RES-4k7
1	Resistor 330	RES-330
2	Resistor 10k	RES-10k

The circuit boards of the BOT117 Inputs Pack require a small number of components to be fitted and a small amount of simple soldering. All components required are supplied.

Assembly Instructions:

Carefully remove all PCBs from the panels by applying a gentle rocking motion to the PCBs until they snap out of the panel. Note that in each case the bottom of the PCB is marked with the gold text label (e.g. button).

Touch Sensor Module

No assembly required.



Terminal Block Module

Solder the 3 way terminal block onto the PCB, ensuring the contacts face away from the microbric connector pads.



Button (push switch) Module

Place the 10k resistor (brown black orange gold) over the black text on the board so that the legs come out the solder pads on the bottom of the board. Resistors can be placed either way around. Solder in position and cut the legs short.

Place the push switch in position and solder.

Slide Switch Module

Place the 10k resistor (brown black orange gold) over the black text on the board so that the legs come out the solder pads on the bottom of the board. Resistors can be placed either way around. Solder in position and cut the legs short.

Place the slide switch in position and solder.



Temperature Sensor Module

Place the 4k7 resistor (yellow violet red gold) over the black text on the board so that the legs come out the solder pads on the bottom of the board. Place the 330 (orange orange red gold) resistor in position.

Resistors can be placed either way around. Solder in position and cut the legs short.

Place the DS18B20 temperature sensor in position Flat edge next to the resistors), solder in position and cut the legs short.



The optional 4 way connector is for connecting an iButton probe, part RSA001 (not supplied).

Assembly Guide - BOT121 Sensors PCB Panel

Qty	Description	Replacement order code
1	<i>PCB panel containing:</i>	
	LDR Light Sensor (Left)	BOT121
	LDR Light Sensor (Right)	BOT121
	Infra-red Rceiver (IR RX)	BOT121
	Infra-red Tranmsitter (IR TX) x 2	BOT121
1	Infra-red Receiver	LED020
2	LDR light sensors	SEN002
2	Infra-red LEDs	LED021
2	10k resistors (brown black orange gold)	RES-10K
2	220 resistors (red red brown gold)	RES-220
2	33 resistors (orange orange black gold)	RES-33

Optional (not included, purchase separately)

1	Infra-red TV style remote control	TVR010A
---	-----------------------------------	---------

The circuit boards of the BOT121 Sensor Pack require a small number of components to be fitted and a small amount of simple soldering. All components required are supplied.

Assembly Instructions:

Carefully remove all PCBs from the panels by applying a gentle rocking motion to the PCBs until they snap out of the panel. Note that in each case the bottom of the PCB is marked with the gold text label (e.g. IR RX).

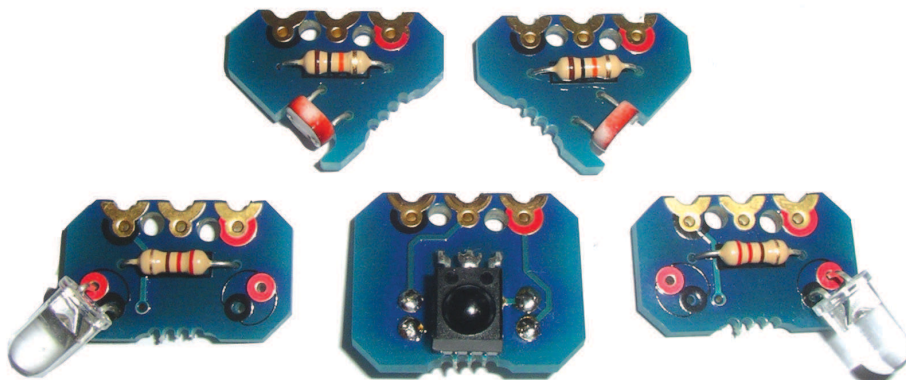

Infra-red Receiver (IR RX)



Important - please note the resistors and infra-red receiver are physically mounted on opposite sides of the module.

Place the two 220 resistors (red red brown gold) over the black text on the bottom of the board so that the legs come out the solder pads on the top of the board. Resistors can be placed either way around. Solder in position and cut the legs short.

Bend the infra-red receiver legs at 90 degrees so that it can lie flat on the top of the PCB between the resistor solder joints. Solder the 3 receiver legs on the other side of the PCB and cut the legs short.



LDR Left and LDR Right

Place the 10k resistor (brown black orange gold) over the black text on the top of the board so that the legs come out the solder pads on the bottom of the board. Resistors can be placed either way around. Solder in position and cut the legs short.

Carefully bend the legs of the LDRs so that it lies in the slot on the PCB with the legs lying over the rectangular gold pads and then through the holes. LDRs can be placed either way around (or facing upwards if preferred). Solder in position and cut the legs short.



Infra-red Transmitter (IR TX)



Note you may only require one IR TX (although two are provided). In this case you may decide to use a coloured LED (not supplied) instead of the infra-red LED on the second board to make a different 'home made' output module.

Place the 33 resistor (orange orange black gold) over the black text on the top of the board so that the legs come out the solder pads on the bottom of the board. Resistors can be placed either way around. Solder in position and cut the legs short.

Carefully bend the legs of the LED so that it points out at 45 degrees to the PCB. The IR LED on the first board should always be in the position nearest the black terminal on the bric connector point. If using two IR LEDs make sure they point in opposite directions on the two boards. The long leg (anode) of the LED must be placed in the red hole. Solder in position and cut the legs short.



BOT127 (optional) Line Tracker / LED Upgrade Pack

Qty	Description	Replacement order code
1	<i>PCB panel containing:</i> Line Tracker Module Quarter Panel Adapter Module LED module	BOT127 BOT127 BOT127
3	14mm posts	BOT126
2	brics	BOT125
10	bolts	BOT125
7	nuts	BOT125

**Assembly:**

Carefully remove all PCBs from the panels by applying a gentle rocking motion to the PCBs until they snap out of the panel. Note that in each case the bottom of the PCB is marked with the gold text label (e.g. LED).

The line follower module is connected to the motherboard by the 3 14mm support posts. This lifts it above the motherboard so that white/black paper can be placed underneath it.

The LED module provides an additional LED for connection to your motherboard.



TVR010A (optional) Infra-red TV Style Remote

Before use, the universal remote control must be programmed with the special 'Sony' transmit code.

1. Insert 2 AAA size batteries, preferably alkaline.
2. Press 'S' and 'B' at the same time. 'S' is in the centre of the arrows.
The top left red LED should light.
3. Press '0'. The LED should flash.
4. Press '1'. The LED should flash.
5. Press '3'. The LED should go out.
6. Press the red power button (top right).



Note that buttons A, C, D, E, F and G are for setting the remote control into different modes which are not required for using the Microbot - the Microbot only ever uses mode B. We recommend always pressing 'B' before use.

Avoid pressing these other letter buttons as this will accidentally set your remote into another mode. You can always return to the 'B' mode by pressing the B button.



Note that it is quite easy to accidentally press the F and G keys when using the arrow keys. If this happens you will need to press B again before the arrow keys will work as expected.

When a key is pressed on the remote control the red LED in its top left corner will light and flash and a number will be sent to the Microbot IR receiver. These numbers will correspond to keys pressed as follows:

Symbol KEY_POWER	= 21
Symbol KEY_UP	= 16
Symbol KEY_DOWN	= 17
Symbol KEY_RIGHT	= 18
Symbol KEY_LEFT	= 19
Symbol KEY_1	= 0
Symbol KEY_2	= 1
Symbol KEY_3	= 2
Symbol KEY_4	= 3
Symbol KEY_5	= 4
Symbol KEY_6	= 5
Symbol KEY_7	= 6
Symbol KEY_8	= 7
Symbol KEY_9	= 8
Symbol KEY_MINUS	= 98
Symbol KEY_0	= 9
Symbol KEY_PLUS	= 11
Symbol KEY_BAR	= 96
Symbol KEY_TENT	= 54
Symbol KEY_VERT_CROSS	= 37
Symbol KEY_DIAG_CROSS	= 20

NB: The six keys at the bottom of the remote are not used.

Programming Example 1 - LED Module

Connect an LED module to outputs B.1 and/or B.3.



The following flowchart will turn the left LED on for half a second, turn that LED off and turn the right LED on for half a second and repeat.

Sample Logicator Flowchart File:
BOT120 LED FLASH TEST.PLF

Sample BASIC File:
BOT120 LED FLASH TEST.BAS



```

main:
  low B.1
  high B.3
  pause 500
  high B.1
  low B.3
  pause 500
  goto main
  
```

Programming Example 2 – Push Button Switch

Connect the push button module to input C.6 and an LED module to B.3. Reading pin C.6 will return a reading of 1 when the button is pushed and a value of 0 when it is not pushed.



The following program tests the operation of the push button by lighting the an LED on the motherboard B.3 when the button is pushed.

Sample Logicator Flowchart File:
BOT120 PUSH SWITCH TEST.PLF

Sample BASIC File:
BOT120 PUSH SWITCH TEST.BAS

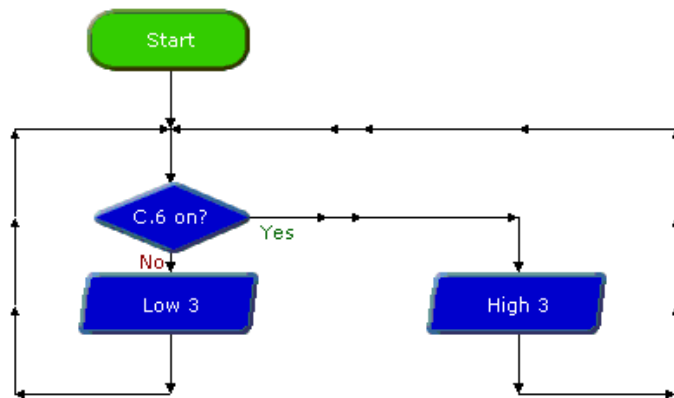

```
main:
  if pinC.6 = 1 then
    high B.3
  else
    low B.3
  end if
  goto main
```

Programming Example 3 – Piezo Sounder

Connect the piezo sounder module connected to output pin B.2 so that it can be used to play a variety of tunes and sounds.



The following program will play the "Happy Birthday" tune whenever the push button (on input pin C.6) on the motherboard is pushed.

Sample Logicator Flowchart File:
BOT120 PIEZO TEST1.PLF

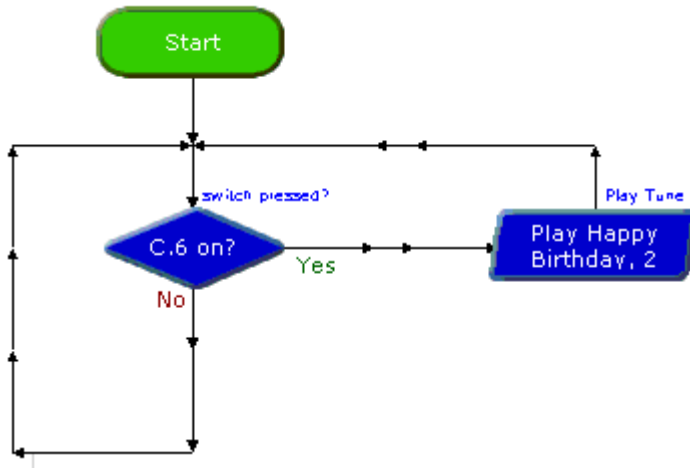

Sample BASIC File:
BOT120 PIEZO TEST1.BAS

```

main:
    if pinC.6 = 1 then
        play B.2,0
    end if
    goto main
    
```

The following program will make a two-tone beep whenever the push button (input pin C.6) on the motherboard is pushed.

Sample Logicator Flowchart File:
BOT120 PIEZO TEST2.PLF

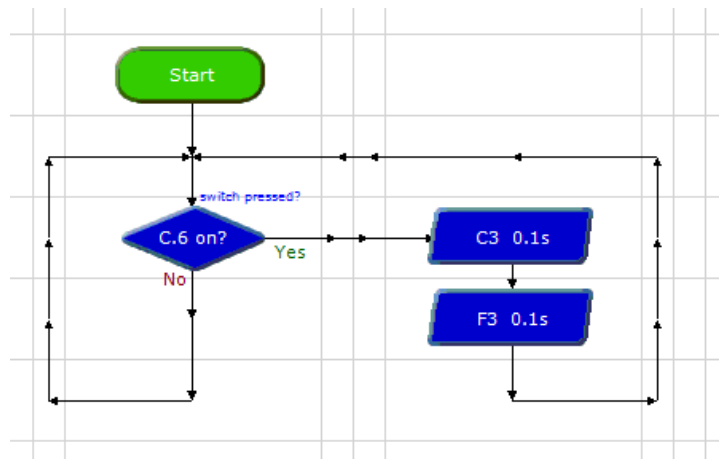

Sample BASIC File:
BOT120 PIEZO TEST2.BAS

```

main:
    if pinC.6 = 1 then
        sound B.2, (50,100,100,100)
    end if
    goto main
    
```

Programming Example 4 – Motors

By controlling the two motors your motherboard could be made to move about. To do this you would need two motor driver modules, one connected to B.3/B.4 and the other connected to B.6/B.7.

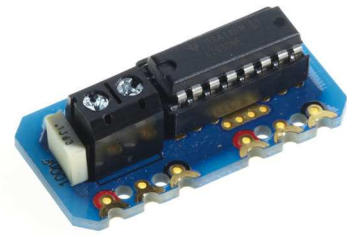

There are four output pins used to control motor directions, left motor drive forward, left motor drive backward, right motor drive forward and right motor drive backward. Motor control pins are assigned as below:

- B.7 Right Motor Backward
- B.6 Right Motor Forward
- B.5 Left Motor Backward
- B.4 Left Motor Forward

Each output pin is individually controllable to allow selection of any of nine completely different robot movement combinations.

Microbot	Right Motor	Right Motor	Left Motor	Left Motor
	Backward B.7	Forward B.6	Backward B.5	Forward B.4
Halt	Low	Low	Low	Low
Forward	Low	High	Low	High
Backward	High	Low	High	Low
Turn Left	Low	High	High	Low
Turn Right	High	Low	Low	High
Veer Left Forward	Low	High	Low	Low
Veer Left Backward	Low	Low	High	Low
Veer Right Forward	Low	Low	Low	High
Veer Right Backward	High	Low	Low	Low

A 'turn' movement is an 'on the spot spin' when one motor is switched forward and the other backward.

A 'veer' movement is created by only switching one motor on at a time.

Logicator Only

When using Logicator these combinations can be very simply generated by clicking the 'movement' buttons on the Motors cell dialog.

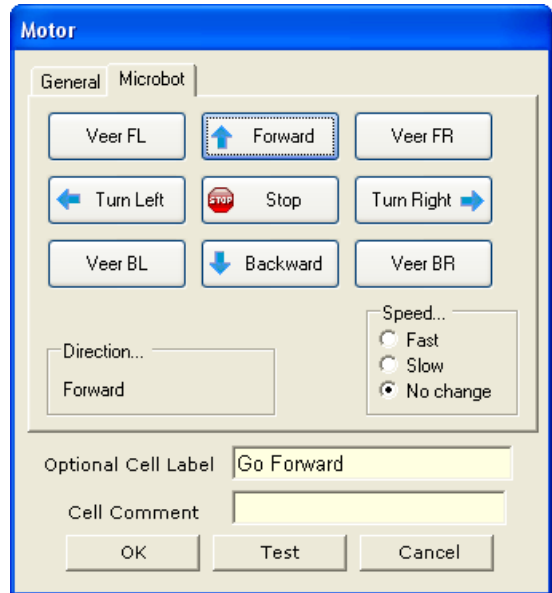

BASIC Only

When using BASIC these movement combinations can be simplified by using the 'forward', 'backward' and 'halt' commands on each of the two motors - motor B is B.7 : B.6 and motor A is B.5 : B.4

```

; Exampe to Move Microbot Forwards
forward A      ; Set Motor A Forward
forward B      ; Set Motor B Forward
    
```

Microbot	Right Motor (B)	Left Motor (A)
Halt	Halt B	Halt A
Forward	Forward B	Forward A
Backward	Forward B	Backward A
Turn Left	Backward B	Backward A
Turn Right	Backward B	Forward A
Veer Left Forward	Forward B	Halt A
Veer Left Backward	Halt B	Backward A
Veer Right Forward	Halt B	Forward A
Veer Right Backward	Backward B	Halt A

Sample Logicator Flowchart File:
BOT120 MOTOR TEST.PLF

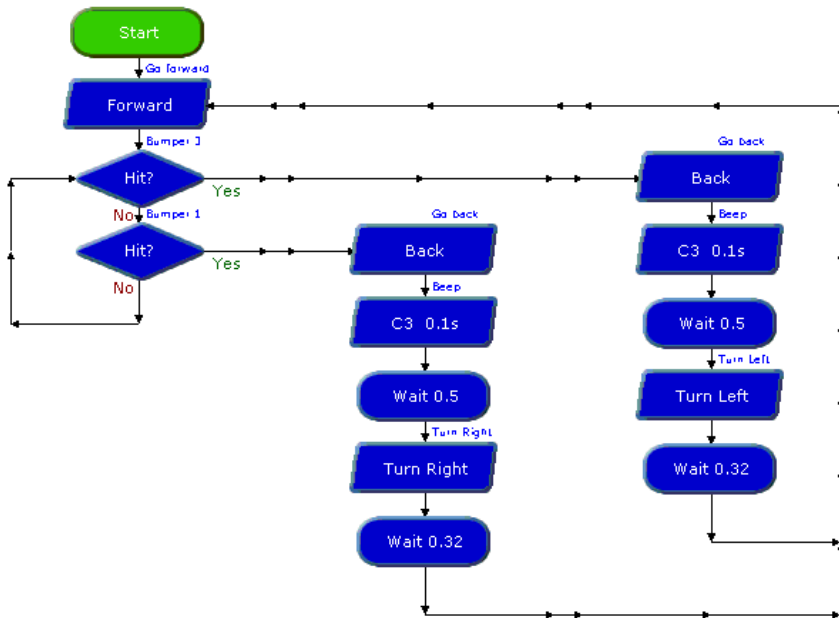

Sample BASIC File:
BOT120 MOTOR TEST.BAS

```

main:
    forward A ; go forwards
    forward B ; test bumpers
                ; to see if hit
    if pinC.2 = 1 then doLeft
    if pinC.1 = 1 then doRight
    goto main

doLeft:
    backward A ; reverse for 0.5s
    backward B
    sound B.2, (50,100) ; beep
    pause 500
    forward A ; turn for 0.32s
    backward B
    pause 320
    goto main

doRight:
    backward A ; reverse for 0.5s
    backward B
    sound B.2, (100,100) ; beep
    pause 500
    backward A ; turn for 0.32s
    forward B
    pause 320
    goto main
    
```

Programming Example 5 – Infra-red Receiver

Connect the IR RX Module to input C.0.

The following program demonstrates waiting for an IR Remote Control key press and reporting what the key code value is of the key pressed.



Sample Logicator Flowchart File:
BOT120 INFRARED TEST.PLF

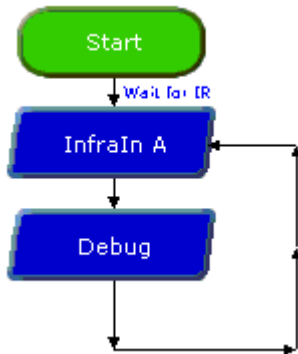

Sample BASIC File:
BOT120 INFRARED TEST.BAS

```
main:
    irin C.0,b1
    debug
    goto main
```

The following flowchart waits for a Remote Control key press and then selects what to do based upon the key pressed. The Microbot will continue to do as instructed until another key is pressed.

Sample Logicator Flowchart File:
BOT120 INFRARED.PLF

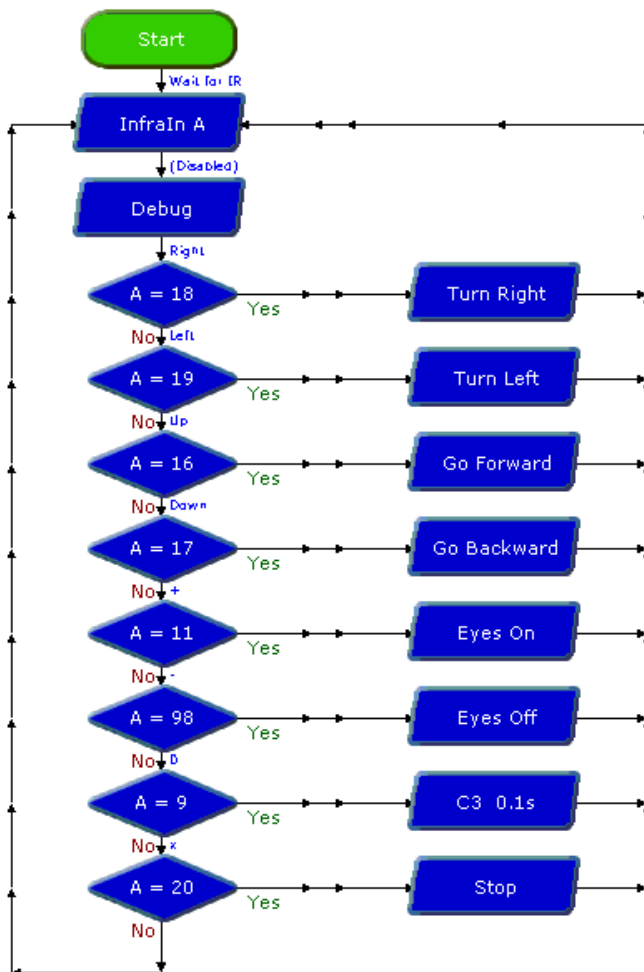

Sample BASIC File:
BOT120 INFRARED.BAS

```
symbol KEY_UP = 16
symbol KEY_DOWN = 17
symbol KEY_LEFT = 19
symbol KEY_RIGHT = 18
symbol KEY_MINUS = 98
symbol KEY_PLUS = 11
symbol KEY_DIAG_CROSS = 20

main:
    irin C.0, b1
    select case b1
        case KEY_UP
            forward A
            forward B
        case KEY_DOWN
            backward A
            backward B
        case KEY_LEFT
            backward A
            forward B
        case KEY_RIGHT
            forward A
            backward B
        case KEY_MINUS
            low B.1, B.3
        case KEY_PLUS
            high B.1, B.3
        case KEY_DIAG_CROSS
            halt A
            halt B
    end select
    goto main
```

Programming Example 6 – Infra-red Transmitter

By using the IR Transmitters it is possible for one motherboard to act like a Remote Control for another.

Connect an IR transmitter (TX) board to pin B.0



To check the IR Transmitters are working fully you will need two Microbots, one sending and one receiving and reporting what it has received. The operation of the IR transmitters is invisible to the human eye but can usually be observed by using a PC webcam, mobile phone camera or camcorder.

Take care not to place any webcam, digital camera or camcorder too close to the IR LEDs to view their operation as this may permanently damage the image sensors. Observing the IR LEDs in this manner is undertaken entirely at your own risk.



The following flowchart will use an IR transmitter connected to the B.0 on the motherboard to act as an automated remote control which can control one (or more) other motherboard which has been programmed to respond to remote control key presses as in the previous infra-red receiving program.

The program repeatedly sends out a simulated up arrow press followed by a down arrow press every five seconds. The receiving Microbot will therefore move forwards for 5 seconds and then backwards for 5 seconds.

Sample Logicator Flowchart File:
BOT120 INFRA TRANSMIT.PLF

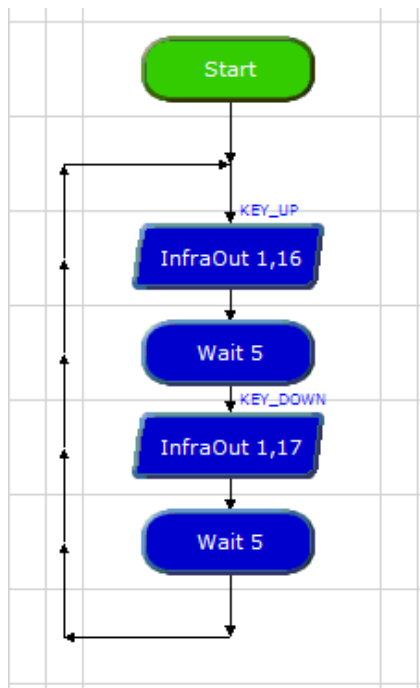

Sample BASIC File:
BOT120 INFRA TRANSMIT.BAS

```

symbol KEY_UP = 16
symbol KEY_DOWN = 17

main:
  irout B.0, 1, KEY_UP
  pause 5000
  irout B.0, 1, KEY_DOWN
  pause 5000
  goto main
  
```

Programming Example 7 – LDR Light Sensor

Connect an LDR light sensor module to input C.1

To determine the light intensity on each LDR perform an analogue read of the appropriate analogue channel. The LDR sensors will give a higher reading for a higher light intensity.

Sample Logicator Flowchart File:
BOT120 LDR TEST.PLF

Sample BASIC File:
BOT120 LDR TEST.BAS

```
main:
    readadc C.1,b7
    debug
    goto main
```



Programming Example 8 – (optional) SRF005 Ultrasonic

Connect the SRF005 Ultrasonic module, via the servo cable and servo module, to pin C.2

The following program will repeatedly initiate a triggering of the ultrasound module and return the distance to an object in front of your SRF005. Distance will be shown in the variable on the Debug screen.

Sample Logicator Flowchart File:
BOT120 SRF005 TEST.PLF

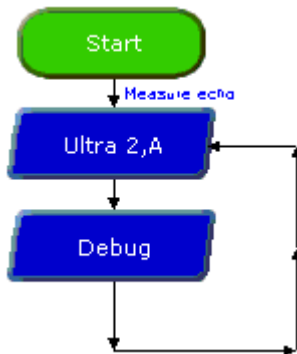

Sample BASIC File:
BOT120 SRF005 TEST.BAS

```
#terminal 9600
main:
  pause 10
  pulsout C.2, 2
  pulsins C.2, 1, w0
  w1 = w0 * 10 / 58 ; Convert to cm
  w2 = w0 * 10 / 148 ; Convert to inches
  sertextd("Distance is ", #w1, "cm",CR,LF)
  sertextd("Distance is ", #w2, "inch",CR,LF)
  goto main
```

Understanding how the SRF005 sensor works.

For Logicator flowcharts use of the SRF005 is very simple, as all the 'hard work' is carried out automatically via the 'ultra' command cell. The BASIC program is slightly more complex.

The Ultrasound Module is controlled by a single pin which both initiates an ultrasonic 'ping' and receives an echoed 'pong'. The length of the returned pulse corresponds to the distance to the object.

The millisecond pulse length value returned by the SRF005 command can be converted to centimetres by dividing by 58 and converted to inches by dividing by 148. As the base unit of the PICAXE-20X2 'pulsin' command is actually 10ms, the pulsins value also needs to be multiplied by 10 prior to dividing.

Note that there should be at least a 10ms pause between each triggering of the SRF005 Ultrasound Module.

Programming Example 9 – Servo

With the (optional) servo connected to the centre rear connector of the motherboard it will be controlled by output Pin B.0.

The following program will turn a connected servo from left to right switching every two seconds.

Sample Logicator Flowchart File:
BOT120 SERVO TEST.PLF

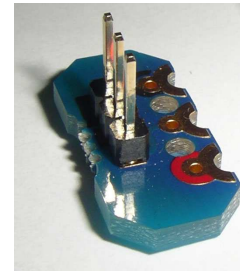
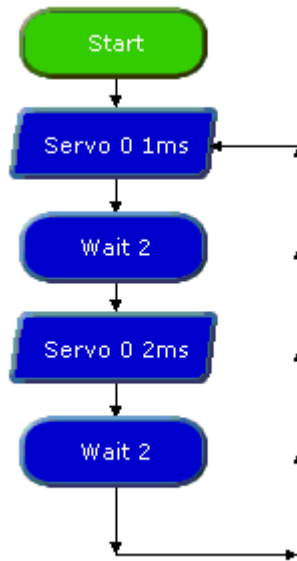

Sample BASIC File:
BOT120 SERVO TEST.BAS

```
main:
  servo B.0, 100
  pause 2000
  servo B.0, 200
  pause 2000
  goto main
```

Appendix 1 - Making your own sensors

For advanced roboteers with appropriate electronics experience it is possible to build your own sensors for your motherboard. The easiest way to do this is to use the servo connector module which has a three pin header which provides direct links to the connection points on the motherboard.

Note the order of the connection point contacts on the servo header:

Pin 1 (Gold)	Signal	Input or Output
Pin 2 (Red)	+V	Power from motherboard (4.5V)
Pin 3 (Black)	0V	0V from motherboard

Note that the motherboard has 220 ohm series protection resistors on all signal lines on the motherboard (see the circuit diagram in the appendix 2). This must be accounted for when designing home made circuits.

The maximum output sink/source current of any i/o pin is 20mA, with a maximum total load of 90mA for all output devices. Exceeding these values may permanently damage your motherboard.

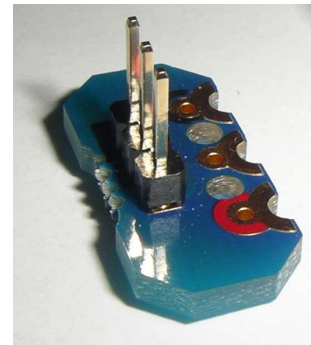

The full assembly instructions and program examples are found in the Microbot manual which is a free download from:

www.rev-ed.co.uk/docs/bot120.pdf

Appendix 2 - BOT115 Motherboard Schematic

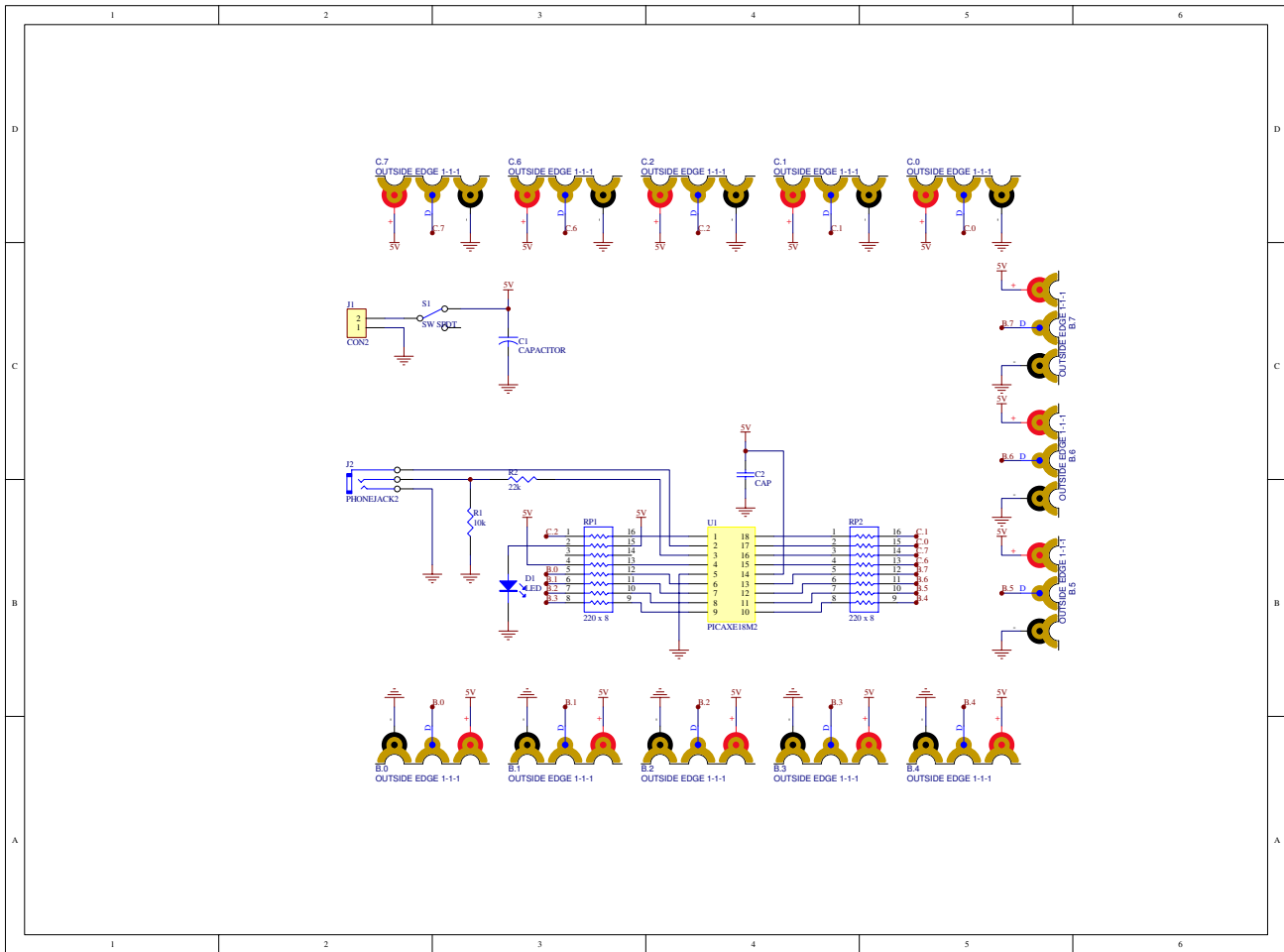

Appendix 3 - BOT116 Output Modules Schematic

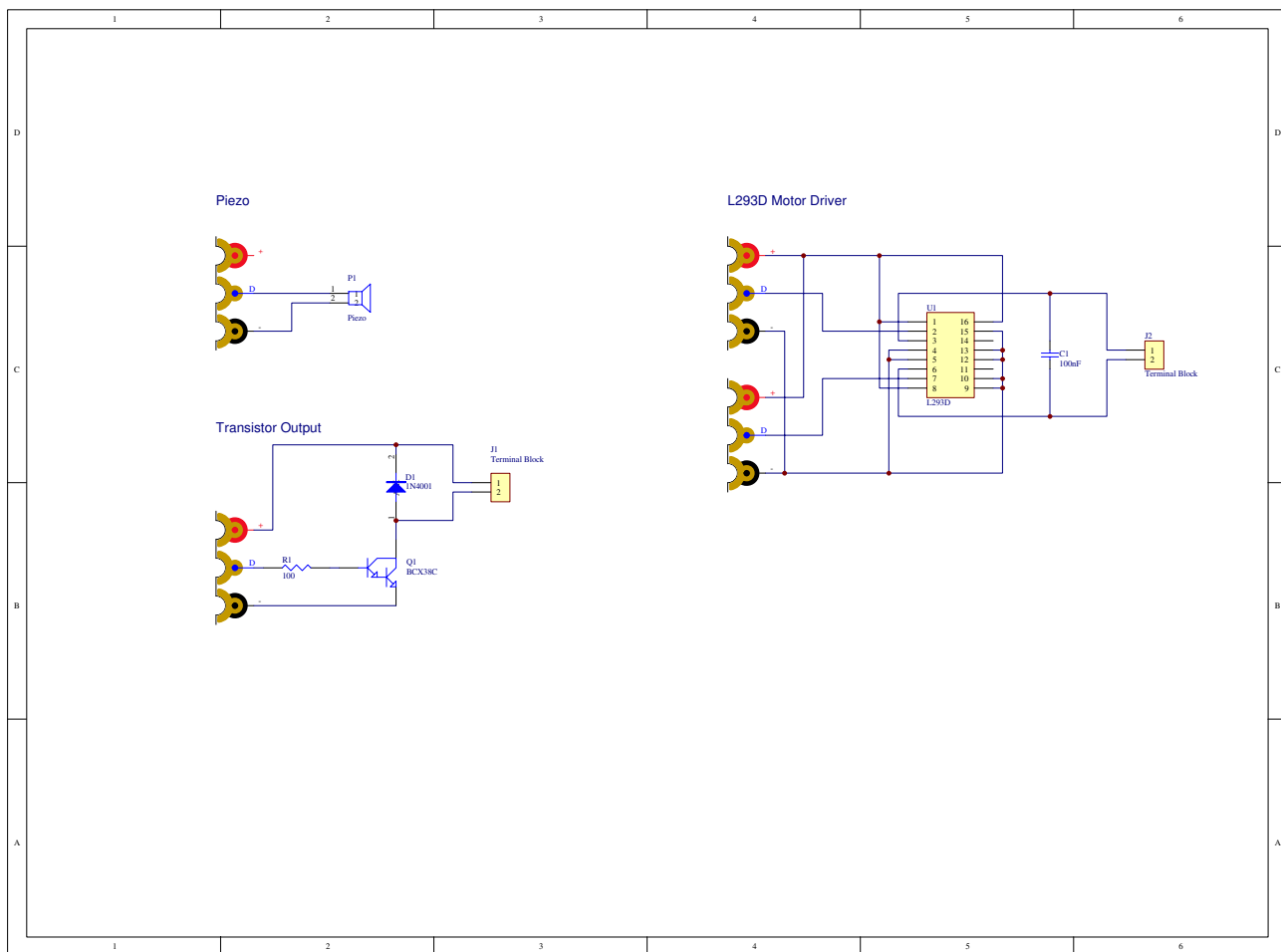

Appendix 4 - BOT117 Input Modules Schematic

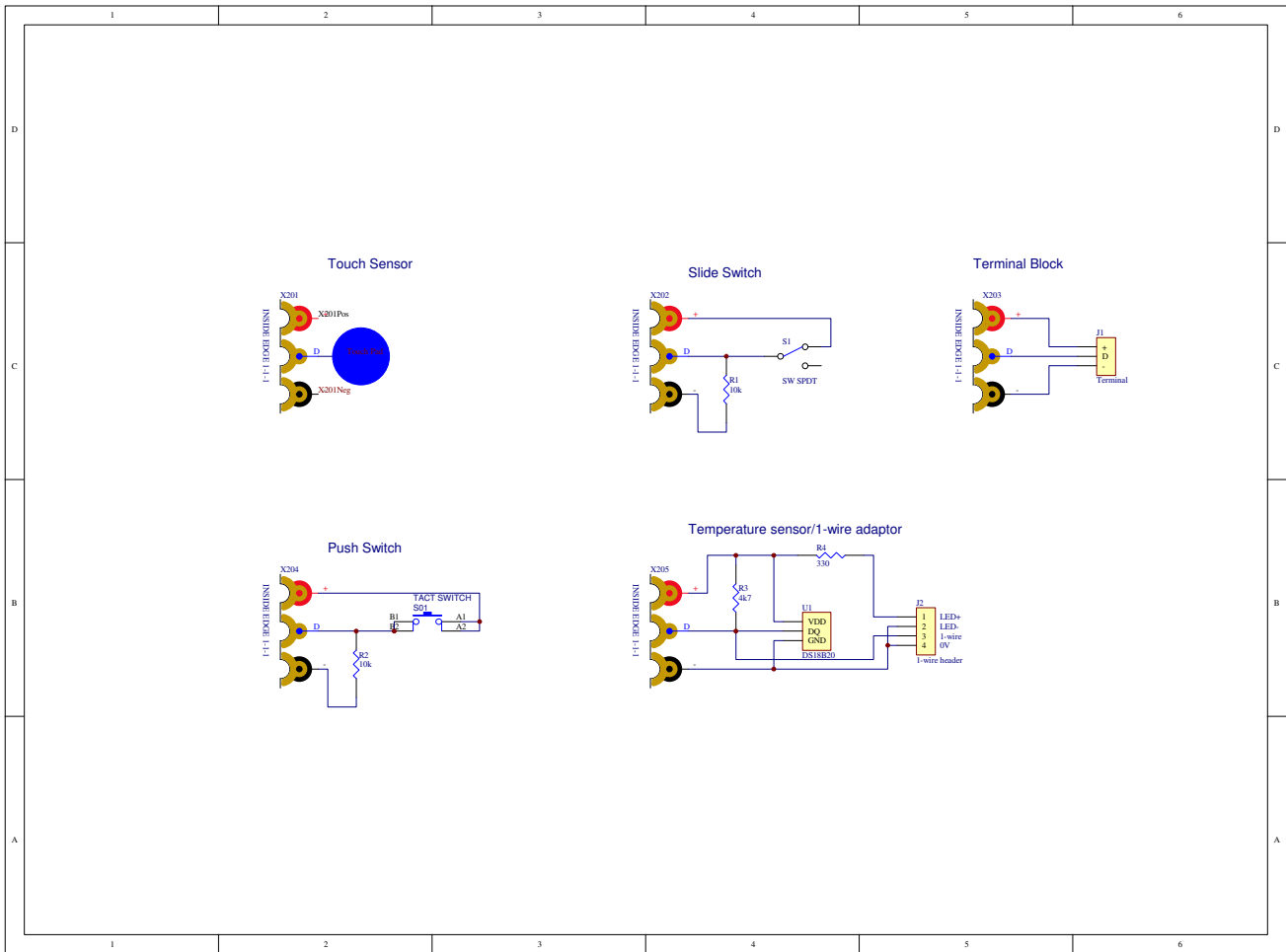

Appendix 5 - BOT121 Sensors Pack Schematic

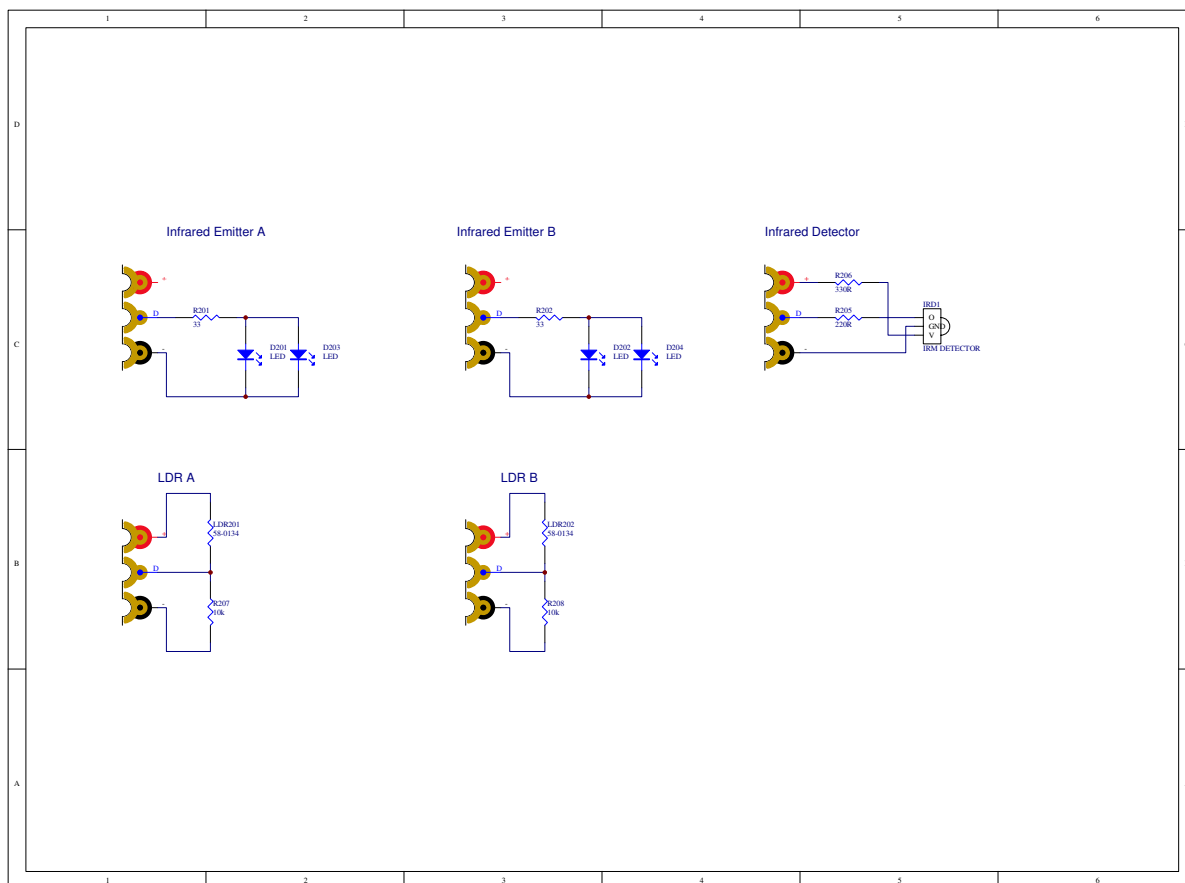

Appendix 6 - BOT123 Servo Pack Schematic

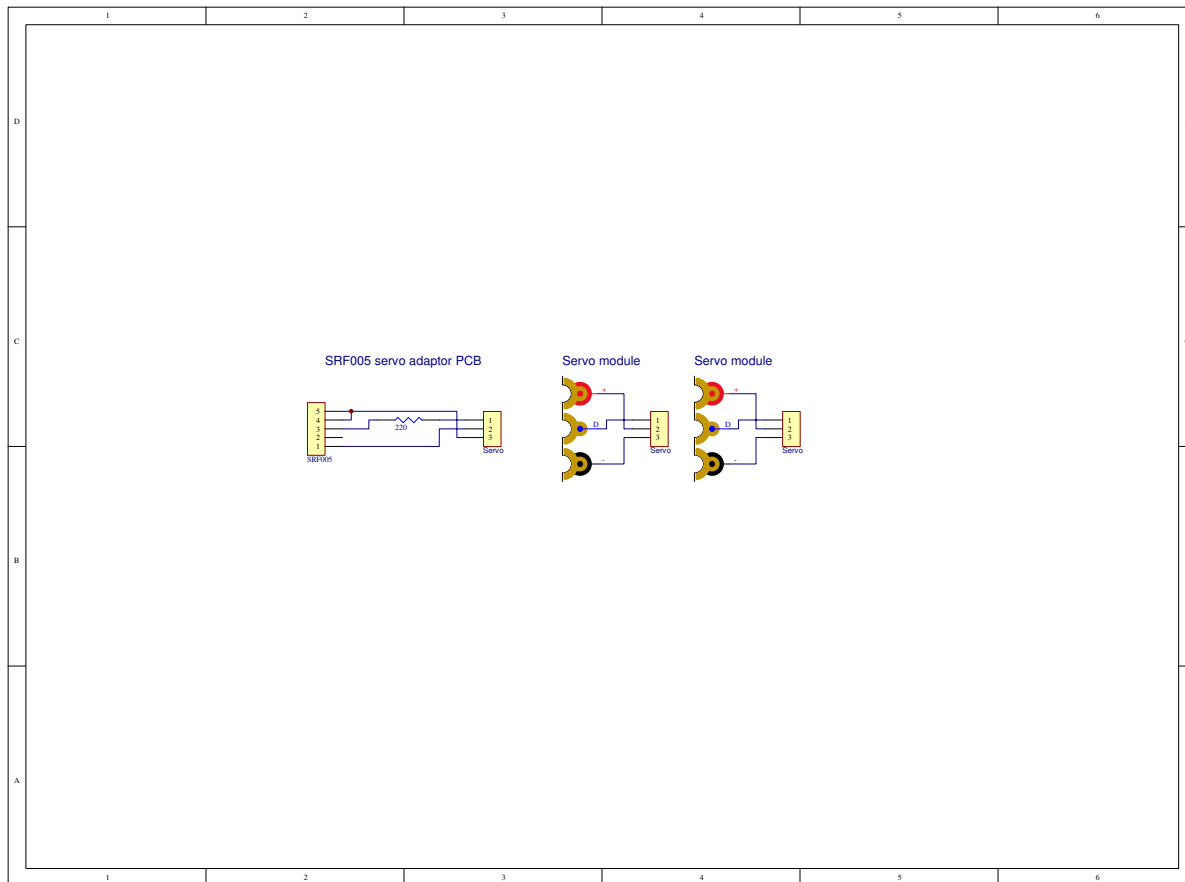

Appendix 7 - Copyright and Trademarks

The PICAXE system, BOT115 Create and BOT115 manual is
(c) Copyright 2010.

This manual may be duplicated for non-profit, educational use in
registered schools, colleges and universities.

PICAXE® products are developed and distributed by
Revolution Education Ltd
Unit 2, Bath Business Park, Foxcote Ave, Bath, BA2 8SF, UK
www.picaxe.com

BOT115 PICAXE Create is a joint venture between Revolution Education
Ltd and Microbric Pty Ltd.
Microbric Pty Ltd
PO Box 8052, Grange, SA 5022, Australia
www.microbric.com

PICAXE® is a registered trademark licensed by Microchip Technology Inc.
Revolution Education is not an agent or representative of Microchip
and has no authority to bind Microchip in any way.

BOT120 Microbot - the robot version motherboard!'

If you enjoyed the create Motherboard you may also be interested in
Microbot - a programmable robot. Modules are interchangeable between
the two models so you can combine kits for more interesting creations!

Fore more details visit www.picaxe.com or contact your local reseller,
asking for part 'BOT120 PICAXE-20X2 Microbot'.

