

SECTION 5 - THE SIMPLE PIC PCB

The Simple PIC project uses a PICAXE-08 microcontroller with three LEDs as outputs. The project also uses a switch so that the project can respond to 'touch', and a Light Dependent Resistor (LDR) so that the project can tell whether it is light or dark.

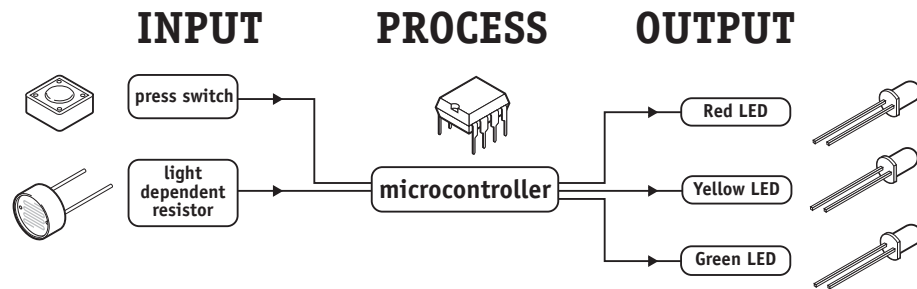

The electronic block diagram is shown below.

- outputs 0, 1, 2 are connected to the LEDs
- input 3 is connected to the push switch
- input 4 is connected to the LDR

Remember not to confuse the chip 'leg' number with the input/output pin number!

Circuit Diagram

The circuit diagram (inputs/outputs) for the Simple PIC project is shown below:

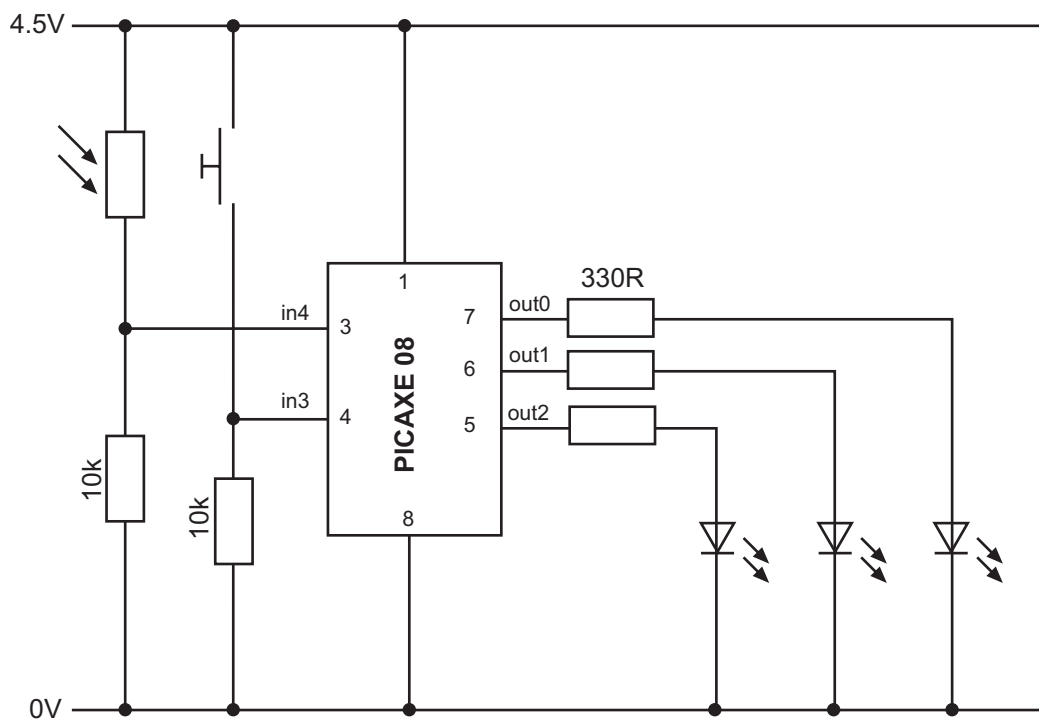

BUILDING THE SIMPLE PIC PCB

What you will need:

R1	22k resistor	(red red orange gold)
R2,3,4	10k resistor	(brown black orange gold)
R5,6,7	330R resistor	(orange orange brown gold)
LED1	5mm red LED	
LED2	5mm yellow LED	
LED3	5mm green LED	
LDR	miniature light dependent resistor	
SW1	miniature 6mm switch	
IC1	8 pin IC socket	
IC1	PICAXE-08 or 08M microcontroller	
CT1	PICAXE download 3.5mm socket	
BT1	battery clip	
BT1	4.5V (3xAA) battery box	
PCB	printed circuit board	

Tools:

soldering iron and solder
side cutters

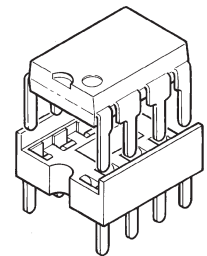
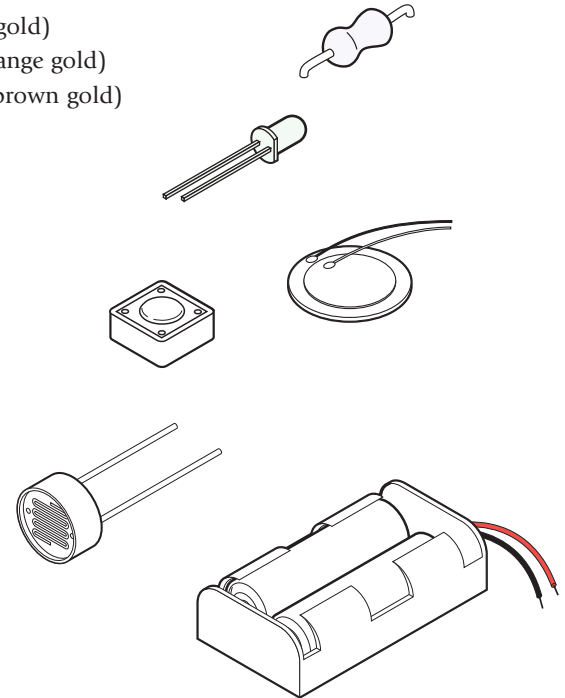

Resistor colour codes

Black	0	0	Black x1	Silver ±10%
Brown	1	1	Brown x10	Gold ±5%
Red	2	2	Red x100	
Orange	3	3	Orange x1000	
Yellow	4	4	Yellow x10,000	
Green	5	5	Green x100,000	
Blue	6	6	Blue x1,000,000	
Violet	7	7		
Grey	8	8		
White	9	9		

Example shown:
 blue, grey, brown, gold
 = 680R ±5%

Soldering the PCB.

The printed circuit board (PCB) is specially manufactured with a 'solder resist' layer to make it simpler to solder. This is the green 'lacquer' layer that covers the tracks so that the solder does not stick to these tracks. However for successful assembly the PCB must be carefully assembled and soldered.

When soldering always make sure the solder iron tip is hot and clean. To test if it is hot enough try to melt a piece of solder on the tip. The solder should melt almost instantly. Then clean off the melted solder by wiping the tip on a damp sponge.

Remember that solder will only 'stick' to hot surfaces. Therefore never melt the solder on the soldering iron tip and then try to 'drop' it onto the joint – this won't work as the joint will be cold and so the solder won't stick.

To successfully solder you must hold the soldering iron in one hand and the solder in the other. Therefore make sure the board is held on the table so it won't move (e.g. use a bulldog clip or get someone else to hold it for you).

Steps to soldering:

- 1) Clean the soldering iron tip on the damp sponge
- 2) Press the soldering iron tip against the pad on the PCB AND the leg of the component. Count to 3 to give the joint time to warm up.
- 3) Keep the soldering iron in position and touch the solder against the joint. Allow enough solder to melt to cover the joint.
- 4) Take the solder away first, then the soldering iron
- 5) Allow the solder to cool for about 5 seconds before trying to move the board.

After each joint is made make sure it does not accidentally 'bridge' across to other joints. However be aware that some solder joints (e.g. on the two sides of the PICAXE download socket) have two wires very close together that are already connected by a track (line) on the PCB. In this case it does not matter if the solder joins together.

Tips!

- 1) Always start with the smallest components like the resistors. Then move onto larger components like the IC socket and then finish with the tall components like capacitors and transistors. Do not try to put all the components in position at once, only do two or three at a time.
- 2) Always make sure that the components lie flat on the board before they are soldered. When using components with long legs like resistors and LEDs, bend the legs so that the component is held firmly in position before soldering.
- 3) Make sure the PICAXE stereo download socket 'snaps' into position flat on the board before it is soldered.
- 4) Make sure that the components that only work one way around (LEDs, diodes, transistors and capacitors) are correctly aligned before soldering (see the marks on the PCB).
- 5) Always thread the battery snap wires down and up through the two thread holes before soldering. This helps make a much stronger joint which is less likely to snap off.

How you build your Simple PIC PCB will depend on the shape and size of your design. You may solder all the components directly onto the board, or you may connect some of the components (e.g. the LEDs, the LDR and the switch) by longer pieces of wire so they can be fitted elsewhere. These instructions presume you are soldering all the components directly on the board. The instructions are identical if you are using longer wires to join some components, although you must

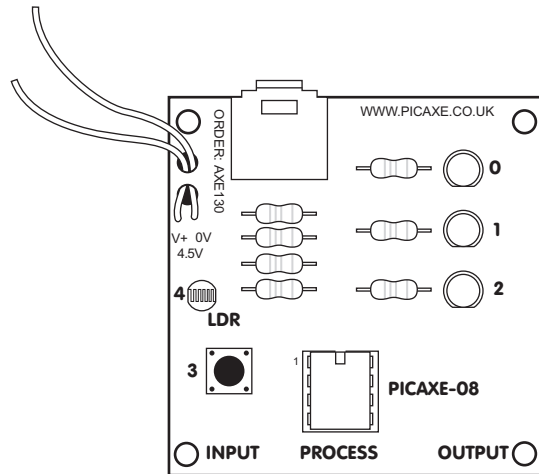

be even more careful you get the wires around the correct way on the LEDs.

- 1) Place the 10k (brown black orange gold) resistors in position. Bend the legs to hold the resistors in position and then solder.
- 2) Place the 22k (red orange gold) and three 330 (orange orange brown gold) resistors in position. Bend the legs to hold the resistors in position and then solder.
- 3) Push the PICAXE stereo download socket onto the PCB and make sure it clicks into position (so that it lies flat on the board). Solder the five metal square contacts (the five round plastic support post holes do not have to be soldered). Do not worry if the solder joins on the two metal contacts either side of the socket as they are supposed to be joined anyway.
- 4) Push the IC socket into position. Make sure the notch at one end points up towards the socket. Fold the legs over to hold the socket in position and then solder.
- 5) Solder the LDR and LEDs into position. Make sure the flat on one side of the LED aligns with the flat marked on the PCB.
- 7) Solder the switch in position (note that it only fits one way around). If using wires solder one wire into either one of the two bottom holes and the other wire into either one of the two top holes.
- 8) Thread the battery clip down through the large hole by the letters AXE (of AXE130). Thread it back up through the large hole by the letters 130. Then solder the black wire in the hole marked 0V and the red wire in the hole marked V+.
- 9) Carefully check the board to make sure there are no missed joints or accidental solder bridges.
- 10) Insert the microcontroller into the socket, ensuring pin1 faces the stereo socket.

