

ELECTRONIC PETS

What is a microcontroller?

A microcontroller is often described as a 'computer-on-a-chip'. It can be used as an 'electronic brain' to control a product, toy or machine.

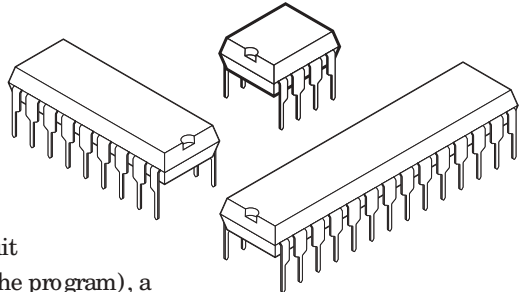

The microcontroller is an integrated circuit ("chip") that contains memory (to store the program), a processor (to process and carry out the program) and input/output pins (to connect switches, sensors and output devices like motors).

Microcontrollers are purchased 'blank' and then programmed with a specific control program. This program is written on a computer and then 'downloaded' into the microcontroller chip. Once programmed the microcontroller is built into a product to make the product more intelligent and easier to use.

Example use of a microcontroller.

In most toy shops there are now lots of intelligent 'toys' available. These toys can move, make noises and respond to being touched or being placed in a dark place.

An example of one such toy is the 'Furby' made by Tiger Electronics. The Furby has a microcontroller as it's electronic 'brain' and reacts (to being touched or being placed in the dark) by moving or making sounds.

The Furby reacts to the outside world by sensors and switches. It has a push switch on it's front and back, a micro switch in it's mouth and a light sensor (LDR) between it's eyes. There is also a microphone on it's side so that it can detect sounds.

The Furby's movement is provided by an electric motor. It also has a speaker to generate sounds and an infra-red LED so that it can send signals to other Furby's that might be nearby.

The microcontroller is the 'brain' of the creature.

Microcontrollers are powerful electronic components that have a memory and can be programmed to switch things on and off in a special sequence. The microcontroller in the Furby, for instance, has been programmed to switch off the motor and speaker when the light sensor has detected it to be dark (i.e. the Furby goes to sleep).

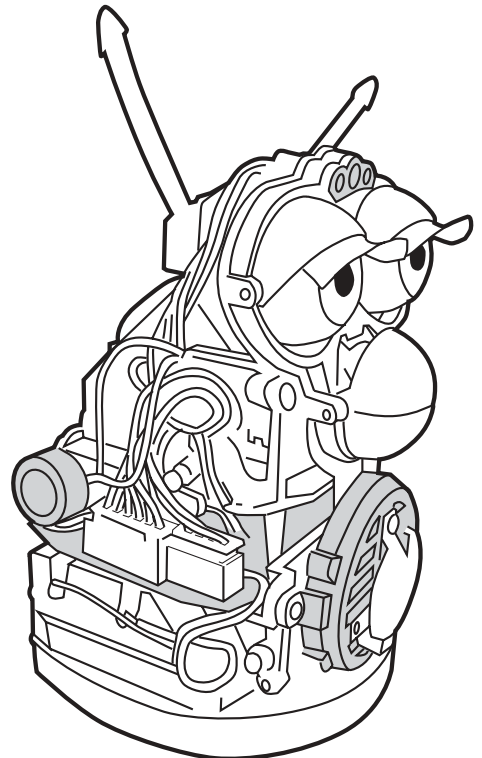

BLOCK DIAGRAMS

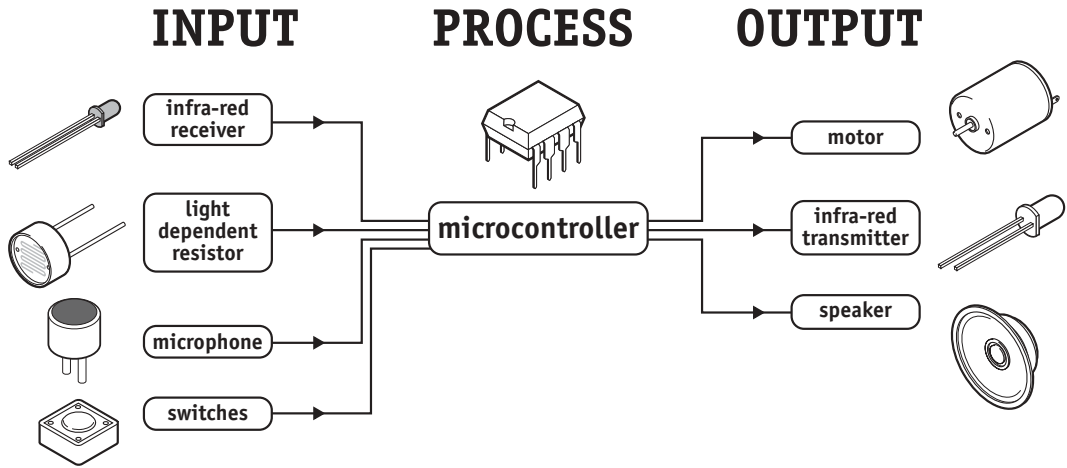

The electronic system that controls the Furby toy can be drawn as a ‘block diagram’. The light sensor, microphone and switches all provide information to the microcontroller, and so these are known as ‘inputs’. The microcontroller then ‘decides’ how to behave and may then operate the outputs e.g. make the motor move or generate a sound with the speaker. If another Furby is nearby they can ‘communicate’ by infra-red signals transmitted, and received, by the microcontroller.

WHAT IS THE PICAXE SYSTEM?

The microcontrollers used in devices such as the Furby can be difficult to program, as they generally use a complicated programming language called ‘assembler code’, which can be quite difficult to learn.

The PICAXE system makes the microcontrollers much easier to program. The control sequence can be drawn (and simulated) on the computer as a flowchart, or written in a simpler programming language called BASIC. This makes it much easier to use the microcontroller as the complicated ‘assembler code’ does not need to be learnt.

A sample BASIC program and flowchart are shown here. In this case both programs do the same thing - flash a light (connected to output 0) on and off every second.

```
main:
    high 0
    wait 1
    low 0
    wait 1
    goto main
```

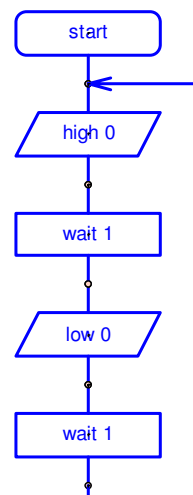

BUILDING YOUR OWN ELECTRONIC CYBERPET

Design Brief

Design and make an electronic 'Rudolf the red nosed reindeer' Christmas decoration 'cyberpet'. The decoration must be programmed with it's own 'personality' so that it reacts in a unique way.

Design Specification Points

- 1) The design will use a PICAXE-08M microcontroller as it's brain.
- 2) The design will include LED eyes and nose, a piezo sounder to play Christmas tunes and could also optionally use a motor to generate movement.
- 3) The design will be able to react to touch and changes in light level.
- 4) The decoration can be designed as a flat '2-dimensional' panel or as a full '3-dimensional' creature.



Block Diagram

The block diagram for your decoration may look like this:

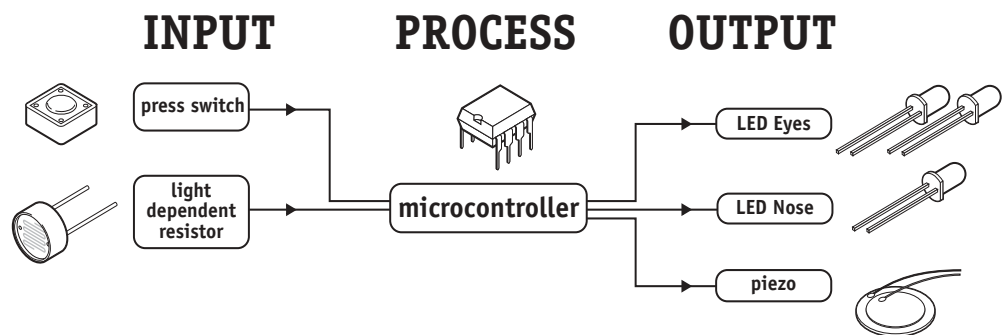

Designing Your Rudolf Cyberpet Decoration

Your decoration can be any shape or size you choose, although you may also use the standard PCB shape. You may like to design the 'face' of the pet using a computer graphics program or by drawing by hand.

Things to think about:

The components can be assembled directly on the PCB. However if you wish to make a '3-dimensional' project the electronic components will need to be mounted inside (or underneath) your cyberpet decoration. The LEDs and LDR will need to poke through holes (5mm for eyes, 10mm for nose). You should also think carefully about where the batteries are going to be stored and where the wires are going to be connected.

ELECTRONIC COMPONENTS

The main electronic components you may need for your cyberpet decoration are shown here. The next few pages describe each of these components in more detail, and also provide some programming ideas that may be useful when you are later programming your rudolf cyberpet with it's own personality:

PICAXE-08M microcontroller

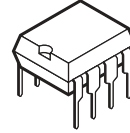

light emitting diode (LED)

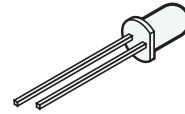

piezo sounder



light dependent resistor (LDR)

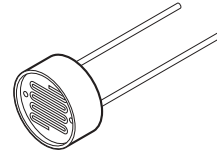

switch

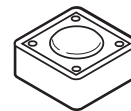

batteries

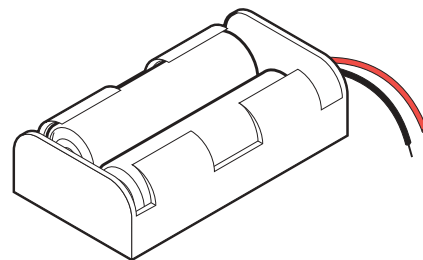

and you will also need

picaxe download socket

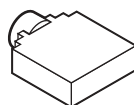

resistors



SECTION 2 - ELECTRONIC COMPONENTS

MICROCONTROLLERS

What is a microcontroller?

A microcontroller is often described as a 'computer-on-a-chip'. It is an integrated circuit that contains memory, processing units, and input/output circuitry in a single unit.

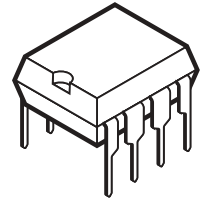

Microcontrollers are purchased 'blank' and then programmed with a specific control program. Once programmed the microcontroller is built into a product to make the product more intelligent and easier to use.

Where are microcontrollers used?

Applications that use microcontrollers include household appliances, alarm systems, medical equipment, vehicle subsystems, and electronic instrumentation. Some modern cars contain over thirty microcontrollers - used in a range of subsystems from engine management to remote locking!

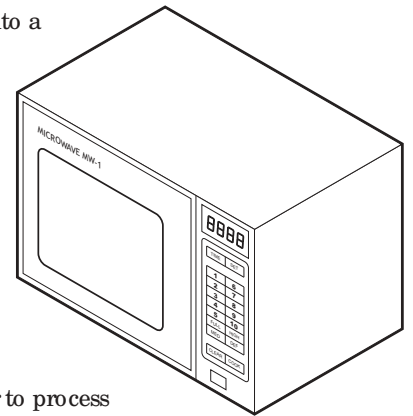

As an example, a microwave oven may use a single microcontroller to process information from the keypad, display user information on the seven segment display, and control the output devices (turntable motor, light, bell and magnetron).

How are microcontrollers used?

Microcontrollers are used as the 'brain' in electronic circuits. These electronic circuits are often drawn visually as a 'block diagram'. For instance a simplified block diagram for the microwave above could be drawn like this:

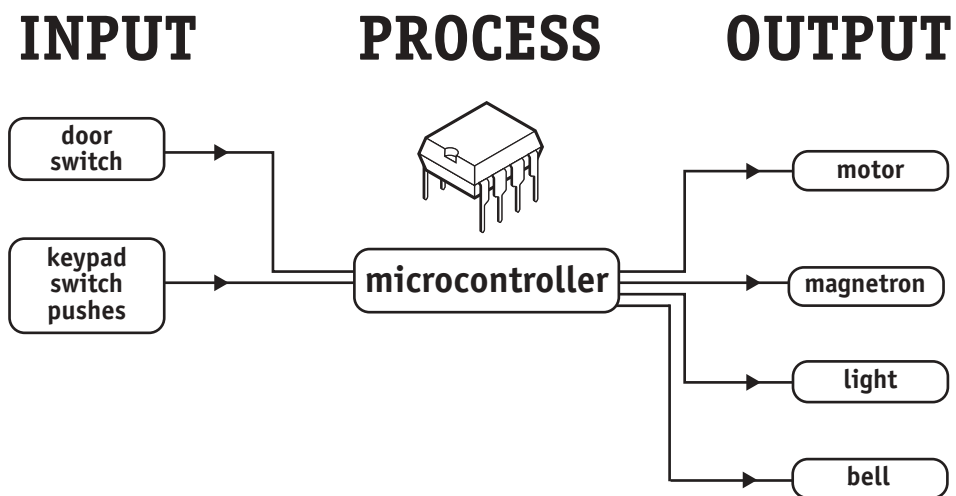

The program for the microcontroller is developed (and tested) on the computer and then downloaded into the microcontroller. Once the program is in the microcontroller it starts to 'run' and carries out the instructions.

How are programs written?

Programs are drawn as flowcharts or typed as 'BASIC' listings. This is explained in the programming section (section 3) later in this booklet.

How is the program transferred to the microcontroller?

The PICAXE-08M microcontroller is programmed by connecting a cable from the serial port at the back of the computer to a socket on the printed circuit board (PCB) beside the microcontroller. This socket (which looks like a headphone socket as found on a portable CD player) connects to two legs of the microcontroller and to 0V from the battery. This allows the computer and the microcontroller to 'talk' to allow a new program to be downloaded into the microcontroller's memory.

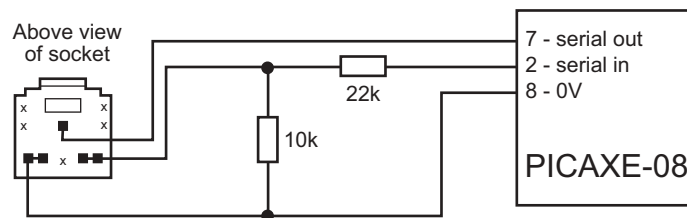

The socket and interfacing circuit is included on every PCB designed to be used with the PICAXE-08M microcontroller. This enables the PICAXE microcontroller to be re-programmed without removing the chip from the PCB - simply connect the cable whenever you want to download a new program!

The circuit diagrams of PICAXE circuits often do not include the components above to make it easier to understand the input/output connections. However the two resistors and the socket are always built onto every PICAXE project board!

Output 0

With the PICAXE-08 system leg 7 has two functions - when a program is being run the leg is known as output 0 and can control outputs like LEDs and motors.

When a program is being downloaded the same leg acts as the 'serial out' pin, 'talking' to the computer. Therefore if you also have an output such as an LED connected to the leg, you will find that the LED will flicker on and off as the program download takes place.

Note:

Most modern computers have two serial ports, normally labelled COM1 and COM2. The Programming Editor software used to create the programs must be configured for the correct serial port - select **View>Options>Serial Port** to select the correct serial port for your machine.

If you are using a new laptop computer it may only have the newer 'USB' type connector. In this case you must buy a USB to serial adapter to use the PICAXE system. These are available from most high street computer stores or online from www.tech-supplies.co.uk (part USB010).

BATTERIES

What is a battery?

A battery is a self-contained source of electronic energy. It is a portable power supply. Batteries contain chemicals that store energy. When connected into a circuit this chemical energy is converted to electrical energy that can then power the circuit.

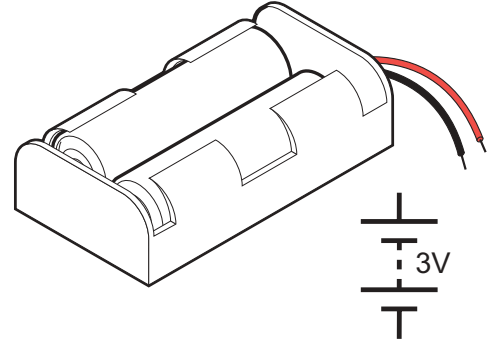

Which battery size should I use?

Batteries come in all sorts of types and sizes. Most battery packs are made up of a number of 'cells', and each cell provides about 1.5V. Therefore 4 cells will generate a 6V battery and 3 cells a 4.5V battery.

As a general rule, the larger the battery the longer it will last (as it contains more chemicals and so will be able to convert more energy). A higher voltage battery does not last longer than a lower voltage battery. Therefore a 6V battery pack made up of 4 AA cells will last much longer than a 9V PP3 battery, as it contains a larger total amount of chemical energy as it is physically larger. Therefore items that require more power to work (e.g. a CD walkman which contains a motor and laser to read the CD's) will always use AA cells rather than PP3 batteries.

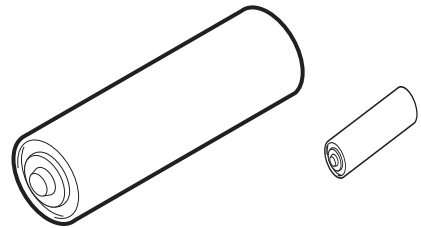

Microcontrollers generally require 3 to 6V to work, and so it is better to use a battery pack made up of three or four AA size cells. Never use a 9V PP3 battery as the 9V supply will damage the microcontroller.

Which battery type should I use?

Different batteries are made of different chemicals. Zinc-carbon batteries are the cheapest, and are quite suitable for many microcontroller circuits. Alkaline batteries are more expensive, but will last much longer when driving devices like motors that require larger currents. Lithium batteries are much more expensive but have a long life, and so are commonly used in computer circuits to provide a clock backup.

Rechargeable batteries can be recharged when they 'run-down'. They are generally made up of nickel and cadmium (Ni-cad) or nickel metal hydroxide (NiMH) chemicals.

Safety!

Never 'short circuit' any battery. Alkaline and rechargeable batteries can provide a very large current, and can get so hot that they will actually melt the battery box if you short circuit them! Always make sure you connect the battery around the correct way (red positive (V+) and black negative (0V or ground)). The microcontroller chip will get hot and be damaged if the battery is connected the wrong way around.

Using battery snaps.

Battery packs are often connected to electronic printed circuit boards by battery snaps. Always ensure you get the red and black wires the correct way around. It is also useful to thread the battery snap through holes on the board before soldering it in place - this provides a much stronger joint that is less likely to snap off.



Never accidentally connect a 9V PP3 battery to the battery snap - this will damage the microcontroller, which only works between 3 and 6V.

Soldering to battery boxes.

Some small battery boxes require wires to be soldered to metal contacts on the battery box. In this case you must be very careful not to overheat the metal contact. If the contacts get very hot they will melt the plastic and fall off. A good way of stopping this happening is to ask a friend to hold the metal contact with a pair of small pliers. The pliers will act as a 'heat-sink' and help stop the plastic melting.

LIGHT EMITTING DIODE (LED)

What is an LED?

A Light Emitting Diode (LED) is an electronic component that gives out light when current passes through it. An LED is a special type of diode. A diode is a component that only allows current to flow in one direction. Therefore when using a diode, it must always be connected the correct way around.

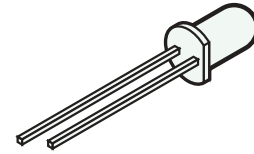

The positive (anode) leg of an LED is longer than the negative (cathode) leg (shown by the bar on the symbol). The negative leg also has a flat edge on the plastic casing of the LED.

What are LEDs used for?

LEDs are mainly used as indicator lights. Red and green LEDs are commonly used on electronic appliances like televisions to show if they are switched on or in 'standby' mode. LEDs are available in many different colours, including red, yellow, green and blue. Special 'ultrabright' LEDs are used in safety warning devices such as the 'flashing lights' used on bicycles. Infra-red LEDs produce infra-red light that cannot be seen by the human eye but can be used in devices such as video remote-controls.

Using LEDs.

LEDs only require a small amount of current to work, which makes them much more efficient than bulbs (this means, for instance, that if powered by batteries the LEDs will light for a much longer time than a bulb would). If too much current is passed through an LED it will be damaged, and so LEDs are normally used together with a 'series' resistor that protects the LED from too much current.

The value of the resistor required depends on the battery voltage used. For a 4.5V battery pack a 330R resistor can be used, and for a 3V battery pack a 120R resistor is appropriate.

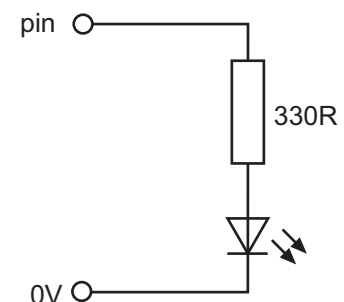

Connecting the LED to a microcontroller.

Because the LED only requires a small amount of current to operate, it can be directly connected between the microcontroller output pin and 0V (with the series protection resistor).

Testing the LED connection.

After connecting the LED it can be tested by a simple program like this:

```
main:
    high 0
    wait 1
    low 0
    wait 1
    goto main
```

This program would switch the LED (connected to output pin 0) on and off every second. If the LED does not work check:

- 1) the LED is connected the correct way around
- 2) the correct resistor is used
- 3) the correct output pin number is being used in the program
- 4) all the solder joints are good

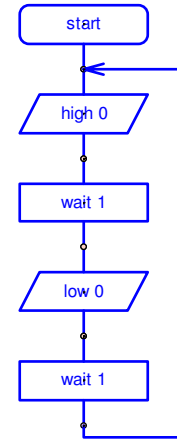

This program flashes the LED connected to output pin 0 on and off 15 times using a BASIC programming technique called a for...next loop (this technique cannot be used with flowcharts). The number of times the code has been repeated is stored in the memory of the PICAXE chip using a 'variable' called b1 (the PICAXE contains 14 variables labelled b0 to b13). A variable is a 'number storage position' inside the microcontroller that the microcontroller can use to store numbers as the program is carried out.

```
main: for b1 = 1 to 15 ' start a for...next loop
      high 0         ' switch pin 0 high
      pause 500      ' wait for 0.5 second
      low 0          ' switch pin 0 low
      pause 500      ' wait for 0.5 second
next b1              ' end of for...next loop

end                  ' end program
```

BUZZERS AND PIEZO-TRANSDUCERS

What is a piezo transducer?

A piezo transducer is a low-cost 'mini-speaker' that can be used to make sounds and play tunes. The sound that the piezo makes can be changed by altering the electronic signals provided by the microcontroller.

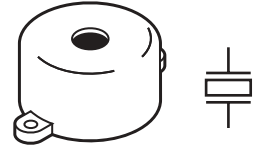

Where are piezos used for?

Piezos are used in many different consumer goods to provide 'feedback' to the user. A good example is a vending machine which will 'beep' whenever a keypad switch is pressed to select a drink or snack. The 'beep' provides the user with feedback to tell them their switch push has been successful. Uncased piezos are also often used in musical birthday cards to play a tune when the card is opened.



What is the difference between a piezo and a buzzer?

A buzzer contains a small electronic circuit that generates the electronic signal needed to make a noise. Therefore when a buzzer is connected to a battery it will always make the same sound. A piezo does not contain this circuit, and so therefore needs an external signal. This signal can be supplied by the output pin of a microcontroller. A piezo also requires less current to operate and so will last longer in battery powered circuits.

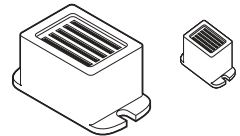

Using piezos.

A piezo is very simple to connect. Simply connect the red wire to the microcontroller output pin and the black wire to 0V (ground).

Note that the cheapest piezos do not have a plastic casing to them. In this case it is necessary to mount the piezo on a piece of board (with a sticky pad) to create a noise that can be heard. The board acts as a 'sound-box' to amplify the sound made by the piezo. Make sure the sticky pad is stuck on the correct side of the piezo (the brass side without the wires!).

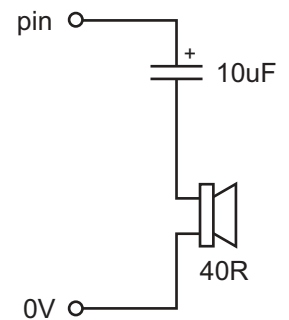
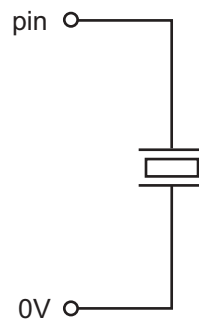

Making More Noise.

Some times you might want to make a louder noise. In this case it is possible to use a speaker instead of the piezo. When using a speaker it is also necessary to use a capacitor (e.g. 10uF electrolytic capacitor) to prevent damage to the microcontroller.

Remember that, like the piezo, a speaker only works correctly when mounted in a 'sound-box'.

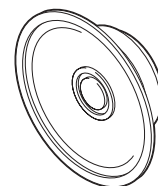

Testing the piezo connection.

After connecting the piezo it can be tested by a simple program like this:

```
main:
    play 3,3
    pause 1000
    goto main
```

This program would make the piezo (connected to output pin 2) play the 'rudolf the red nosed reindeer' tune. The LEDs on the nose and eyes will also flash whilst the tune is played. If the piezo does not work check:

- 1) the piezo is correctly mounted
- 2) all the solder joints are good

Choosing a tune

The PICAXE-08M has 4 tunes pre-programmed. These tunes are as follows:

```
play 3,0    ` Happy Birthday
play 3,1    ` Jingle Bells
play 3,2    ` Silent night
play 3,3    ` Rudolf the Red Nosed Reindeer
```

However it is also possible to import your own mobile phone ring tone (RTTTL format for Nokia phones). This tune can then be played on the PICAXE-08M with the 'tune' command. Therefore if you download a Christmas Carol or tune in ring tone format from the internet, you can play this on your Rudolf cyberpet. There are many free Christmas tunes to download on the software page at www.picaxe.co.uk

PICAXE-08M Tune Wizard

The Tune Wizard allows musical tunes to be created for the PICAXE-08M. Tunes can be entered manually using the drop-down boxes if desired, but most users will prefer to automatically import a mobile phone monophonic ringtone. These ringtones are widely available on the internet in RTTTL format (used on most Nokia phones). Note the PICAXE can only play one note at a time (monophonic), and so cannot use multiple note (polyphonic) ringtones.



There are approximately 1000 tunes for free download on the software page of the www.picaxe.co.uk website. Some other possible sources for free ringtones are:

<http://www.ringtonerfest.com/>
<http://www.free-ringtones.eu.com/>
<http://www.tones4free.com/>

To start the Tune Wizard click the PICAXE>Wizard>Tune Wizard menu.

The easiest way to import a ringtone from the internet is to find the tune on a web page. Highlight the RTTL version of the ringtone in the web browser and then click Edit>Copy. Move back to the Tune Wizard and then click Edit>Paste Ringtone.

To import a ringtone from a saved BASIC (.bas) text file, click File>Import Ringtone.

Once the tune has been generated, select whether you want outputs 0 and 4 to flash as the tune plays (from the options within the 'Outputs' section).

The tune can then be tested on the computer by clicking the 'Play' menu (if your computer is fitted with soundcard and speakers). The tune played will give a rough idea of how the tune will sound on the PICAXE, but will differ slightly due to the different ways that the computer and PICAXE generate and playback sounds. On older computers the tune generation may take a couple of seconds as generating the tune is very memory intensive.

Once your tune is complete click the 'Copy' button to copy the tune command to the Windows clipboard. The tune can then be pasted into your main program.

Tune Wizard menu items:

File	New	Start a new tune
	Open	Open a previously saved tune
	Save As	Save the current tune
	Import Ringtone	Open a ringtone from a text file
	Export Ringtone	Save tune as a ringtone text file
	Export Wave	Save tune as a Windows .wav sound file
	Close	Close the Wizard
Edit	Insert Line	Insert a line in the tune
	Delete Line	Delete the current line
	Copy BASIC	Copy the tune command to Windows clipboard
	Copy Ringtone	Copy tune as a ringtone to Windows clipboard
	Paste BASIC	Paste tune command into Wizard
Play	Paste Ringtone	Paste ringtone into Wizard
	Play	Play the current tune on the computer's speaker
Help	Help	Start the help file.

Ring Tone Tips & Tricks:

1. After generating the tune, try adjusting the tempo by increasing or decreasing the speed value by 1 and listening to which 'speed' sounds best.
2. If your ringtone does not import, make sure the song title at the start of the line is less than 50 characters long and that all the text is saved on a single line.
3. Ringtones that contain the instruction 'd=16' after the description, or that contain many notes starting with 16 or 32 (the odd one or two doesn't matter) will not play correctly at normal speed on the PICAXE. However they may sound better if you double the PICAXE processor speed by using a 'setfreq m8' command before the tune command.
4. The PICAXE import filters 'round-down' dotted notes (notes ending with '.'). You may wish to change these notes into longer notes after importing.

DIGITAL SENSORS (SWITCHES)

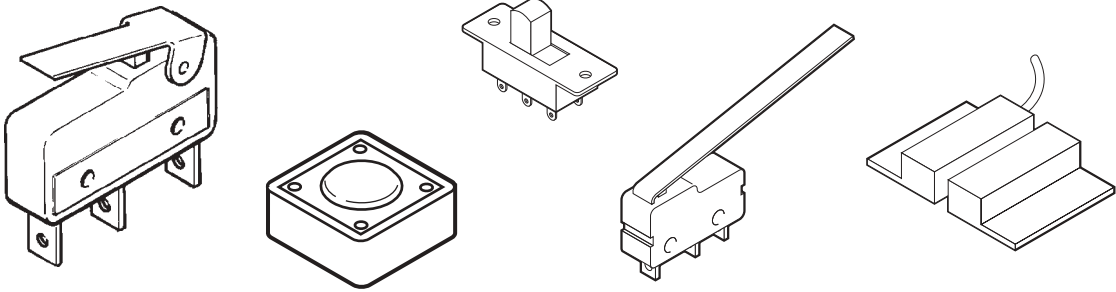

What are switches?

A digital sensor is a simple 'switch' type sensor that can only be 'on' or 'off'. If a graph is drawn of the on-off signals as the switch is pushed it will look like this:

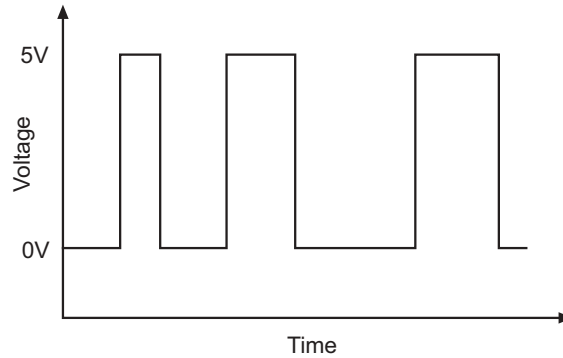

Switches are electronic components that detect movement. There are a large number of different types of switches e.g:

- push switches that detect a momentary 'push'
- micro-switches with long levers that detect small movements
- tilt-switches that detect jolting
- reed-switches that detect a magnet being moved

What are switches used for?

Push switches are commonly used on device like keypads. Micro-switches are used in burglar alarms to detect if the cover is removed from the alarm box. Reed switches are used to detect doors and windows being opened and tilt switches are often used to detect movement in devices such as toys, hair-dryers and tool-box alarms.

Switch Symbols.

The symbols for a slide switch and a push switch are shown here.

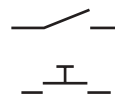

Using switches

A switch is used with a resistor as shown in the diagram. The value of the resistor is not that important, but a 10k resistor is often used. When the switch is 'open' the 10k resistor connects the microcontroller input pin up to V+, which gives a logic level 1 (4.5V) signal to the microcontroller input pin.

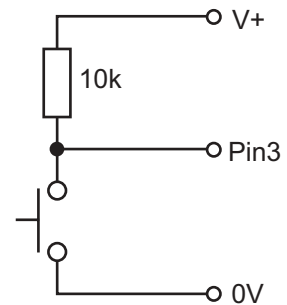

When the switch is activated, the input pin is connected to the negative (ground) supply (0V). This provides a logic level 0 (0V) signal to the microcontroller.

This layout is a little confusing, as it means that when the switch is pushed down, the logic level is '0'. When the switch is not pushed the logic level is '1'. This is known as an 'active-low' switch. In this project this is necessary for compatibility with the optional infra-red upgrade kit.

Testing the switch

After connecting the switch it can be tested by a simple program like this. This program will switch an output on and off according to if the switch is pushed or not.

```

main:                                     ` make a label called 'main'
    if input3 = 0 then flash             ` jump if the switch is pressed
    goto main                           ` else loop back around

flash:                                    ` make a label called 'flash'
    high 0                               ` switch output 0 on
    wait 2                               ` wait 2 seconds
    low 0                                ` switch output 0 off
    goto main                             ` jump back to start
    
```

In this program the first three lines make up a continuous loop. If the input is off the program just loops around time and time again.

If the switch is then pushed the program jumps to the label called 'flash'. The program then flashes output 0 on for two seconds before returning to the main loop.

Note carefully the spelling in the if...then line – **input3** is all one word (without a space). You can use the word **pin3** or **input3** to mean the same thing. Note also that only the label is placed after the command **then** – no other words apart from a label are allowed at this point.

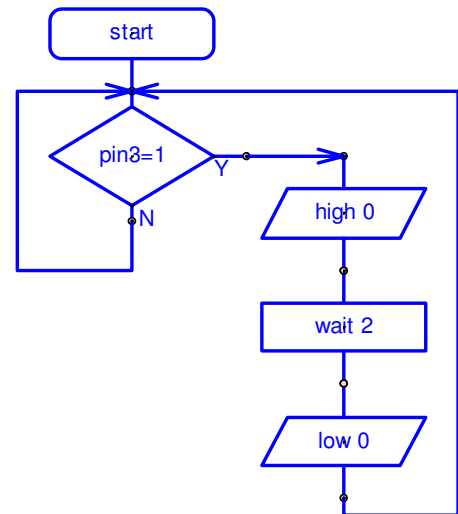

LIGHT DEPENDENT RESISTOR (LDR)

What is an LDR?

A Light Dependent Resistor (LDR) is special type of resistor that reacts to changes in light level. The resistance of the LDR changes as different amounts of light fall on the top 'window' of the device. This allows electronic circuits to measure changes in light level.

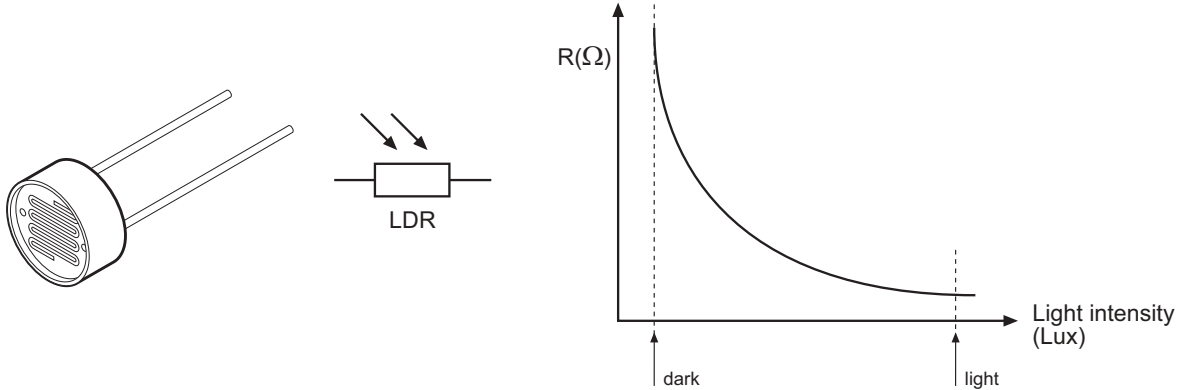

What are LDRs used for?

LDRs are used in automatic street lamps to switch them on at night and off during the day. They are also used within many alarm and toys to measure light levels.

The LDR is a type of **analogue sensor**. An analogue sensor measures a continuous signal such as light, temperature or position (rather than a digital on-off signal like a switch). The analogue sensor provides a varying voltage signal. This voltage signal can be represented by a number in the range 0 and 255 (e.g. very dark = 0, bright light = 255).

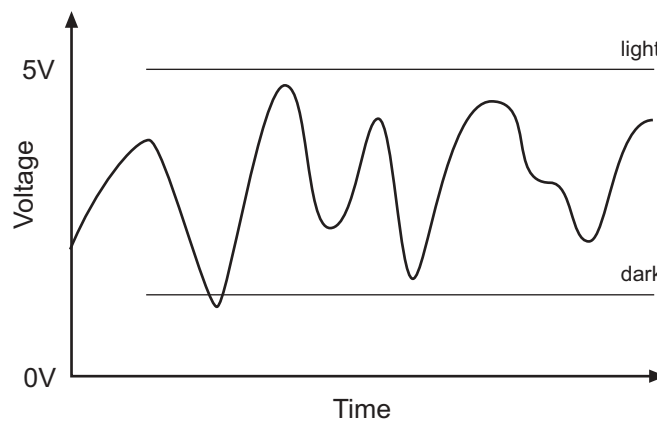

Using LDRs.

A LDR can be used in two ways. The simplest way to use an LDR is as a simple on-off ("digital") switch - when the light level is above a certain value (called the 'threshold value') the LDR will provide an on signal, when the light level is below a certain value the LDR will provide an off signal.

In this case the LDR is used in a potential divider with a standard resistor. The value of the standard resistor sets the 'threshold value'. For miniature LDRs a suitable value may be 1k or 10k, for larger ORP12 type LDRs 10k is more appropriate. If desired the fixed resistor can be replaced by a variable resistor so that the threshold value can be 'tuned' to different light values.

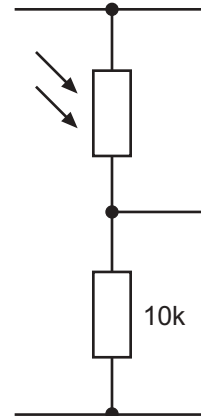

A more versatile way of using the LDR is to measure a number of different light values, so that decisions can be made at varying light levels rather than just one fixed threshold value. A varying value is known as an 'analogue' value, rather than a digital 'on-off' value. To measure analogue values the microcontroller must contain an 'analogue to digital converter (ADC)' and the programming software must support use of this ADC. Most microcontrollers only contain ADC on certain input pins, and so the input pin connection must be carefully selected. With the 8 pin microcontroller only pin1 can be used.

The electronic circuit for using the ADC is a potential divider identical to the circuit above. The analogue 'measurement' is carried out within the microcontroller itself.

Calibrating the LDR (used as analogue input)

When using analogue sensors it is often necessary to calculate the 'threshold' value necessary for the program (ie the values 50 and 100 in the analogue program overleaf). The debug command provides an easy way to see the 'real-time' value of a sensor, so that the threshold value can be calculated by experimentation.

```

main:                \ make a label called main
    readadc 1,b1      \ read channel 1 into variable
    debug b0          \ transmit value to computer
    pause 500         \ short delay
    goto main         \ jump back to the start
    
```

After this program is run a 'debug' window showing the value of variable b0 will appear on the computer screen. As the Light falling on the LDR sensor is altered, the variable value will show the current sensor reading.



The debug window opens automatically after a download, but can also be opened manually at any time via the PICAXE>Debug menu.

Testing the LDR (digital)

After connecting the LDR it can be tested as a digital switch by a simple program like this:

```

main:
    if input1 is on then dohigh
    low 0
    goto main

dohigh:
    high 0
    goto main
    
```

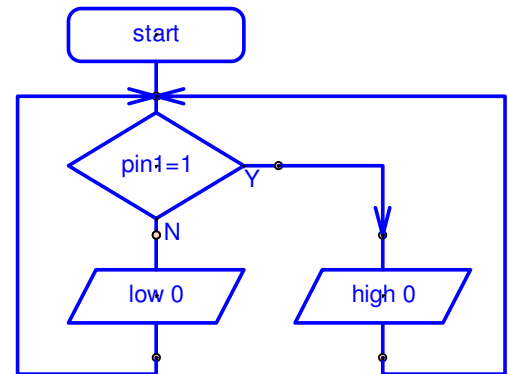

This program will switch output 0 on and off according to the light level.

Testing the LDR (analogue)

After connecting the LDR it can be tested as an analogue sensor by a program like this:

```

main:
    readadc 1,b1
    if b1 > 100 then do4
    if b1 > 50 then do0
    low 0
    low 4
    goto main

do4:
    high 4
    low 0
    goto main

do0:
    high 0
    low 4
    goto main
    
```

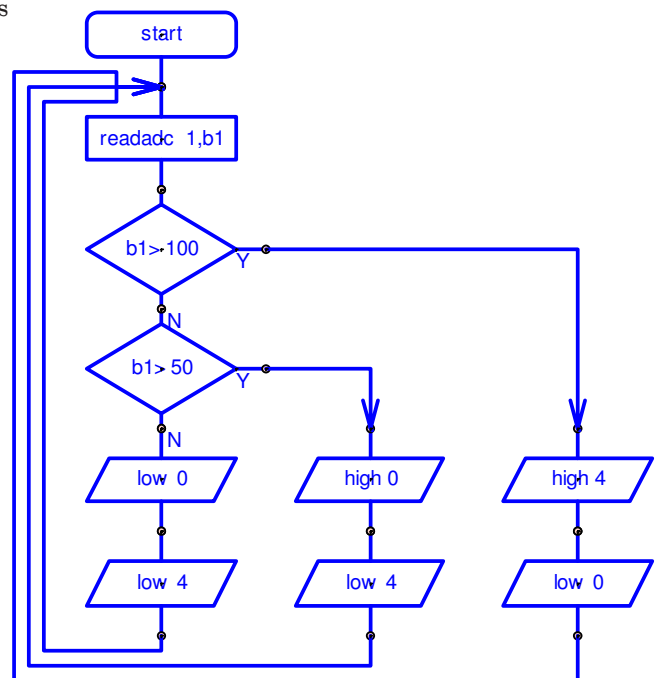

The 'readadc' command is used to read the analogue value (a number between 0 and 255) into variable b1. Once the number is in variable b1 it can be tested to see if it is greater than 100 or greater than 50. If it is greater than 100 output 4 is switched on, if it is between 50 and 100 output 0 is switched on, and if it is less than 50 both outputs are switched off.

SECTION 3

PROGRAMMING - DRAWING FLOWCHARTS

Flowcharts are a useful tool that allow programs to be drawn graphically to make them easier to understand. The Programming Editor software includes a flowchart editor that allows flowcharts to be drawn on screen. These flowcharts can then be converted to BASIC listings for download into the PICAXE. The flowcharts can also be printed or exported as graphics files for inclusion within project portfolios.

Detailed instructions for drawing/downloading a flowchart:

1. Connect the PICAXE cable to the computer serial port. Note which port it is connected to (normally labelled COM1 or COM2).
2. Start the Programming Editor software.
3. Select View>Options to select the Options screen (this may automatically appear).
4. Click on the 'Mode' tab and select PICAXE-08
5. Click on the 'Serial Port' tab and select the serial port that the PICAXE cable is connected to. Click 'OK'
6. Start a new flowchart by clicking the File>New Flowchart menu.
7. Draw the flowchart by dragging the correct symbols onto the screen, and then using the mouse to draw arrows between the symbols.
8. Once the flowchart is complete it can be converted into a BASIC program by selecting Flowchart>Convert Flowchart to BASIC. The BASIC program can then be downloaded into the PICAXE by clicking the PICAXE>Run menu.
9. To print or save the flowchart, use the File menu options. To export the flowchart as a graphic file, use the File>Export menu. To publish the image in a Word document select file type EMF To publish the flowchart on an internet web page use the GIF file type.

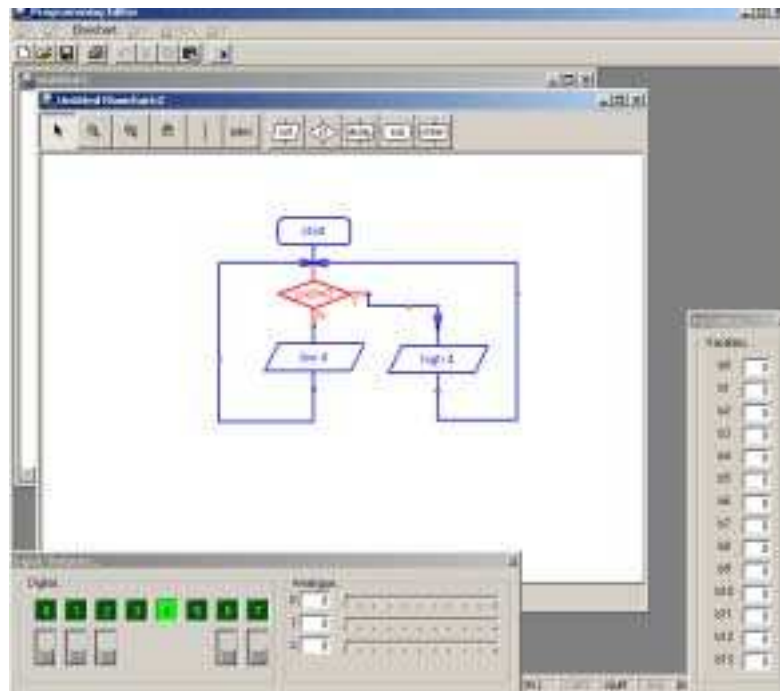

Flowchart Screen

The Flowchart Editor allows flowcharts to be drawn and simulated on-screen. The flowchart can then be automatically converted into a BASIC program for downloading into the microcontroller.

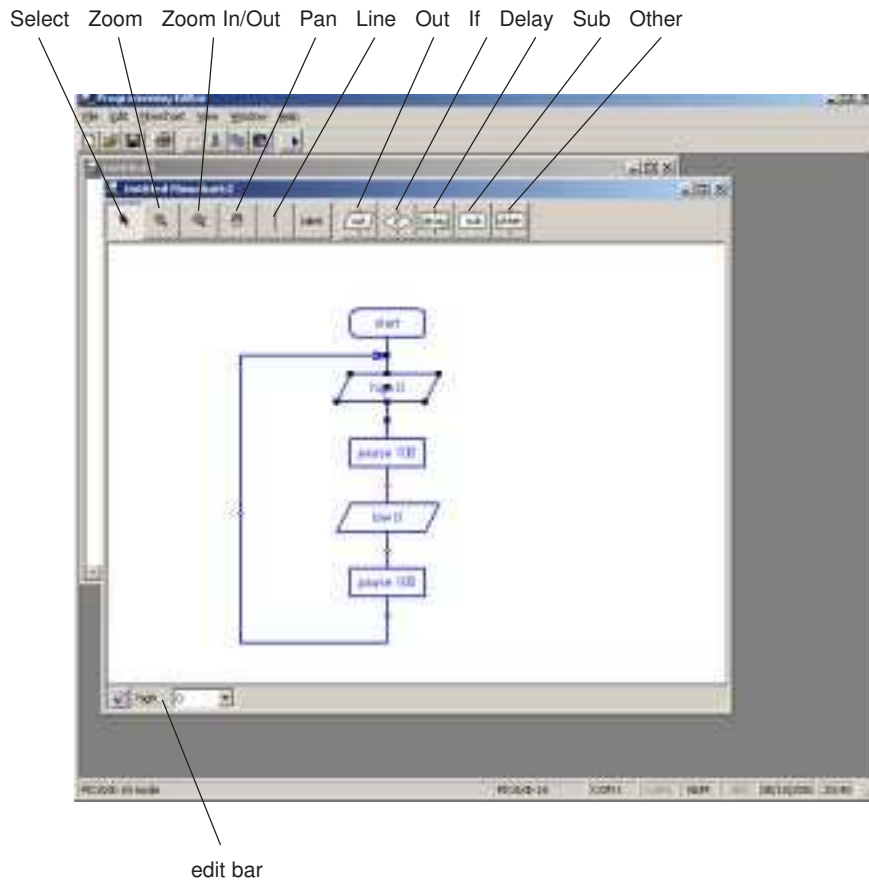

Flowchart Screen

Select Tool

Use this to select and move shapes. When a single shape is selected it's BASIC code can be edited in the edit bar at the bottom of the window.

Zoom

Use to zoom in to an area of the graph. Right click to zoom out.

Zoom In/Out

To zoom in click and move the mouse up. To zoom out click and move the mouse down.

Pan

Use this tool to move around the flowchart.

Line Tool

Use this tool to draw lines between shapes. Corners can be added by clicking once. When the line is near to a shape it will 'snap' to the connection point.

Label Tool

Use this tool to add descriptive labels or titles to the flowchart.

Out / If / Delay / Sub / Other

Click on these buttons to move to the command sub-menu to select commands.

Drawing Flowcharts

To draw a flowchart click on one of the command menu buttons (out / if / delay / sub / other) on the toolbar to move to the appropriate command sub-menu. Select the appropriate command and then click on the screen where the shape is required. Do not try to locate the shape precisely at first – just drop it in the general area and then use the select tool to move the shape to the correct position.

Once the shape is in position click on it so that it is highlighted. The BASIC code for the shape will then appear in the edit bar at the bottom of the screen. Edit the code as required.

For further information about each command see the 'BASIC Commands' help file.

Joining Shapes

Shapes are joined by moving them close together until they 'snap' together. Alternately lines can be drawn between the shapes using the 'line tool' from the main toolbar. Note that it is only possible to join the bottom (side) of shapes to the top of other shapes (you cannot connect lines to lines). Only one line is allowed out of the bottom of each shape.

To enable neat diagrams, corners to the lines can be added by clicking with the mouse. When a line moves close to a connection point it will snap into position and then a click will finish the line.

Lines cannot be moved. If you try to move a line it will be deleted and a new line must be created.

On Screen Simulation

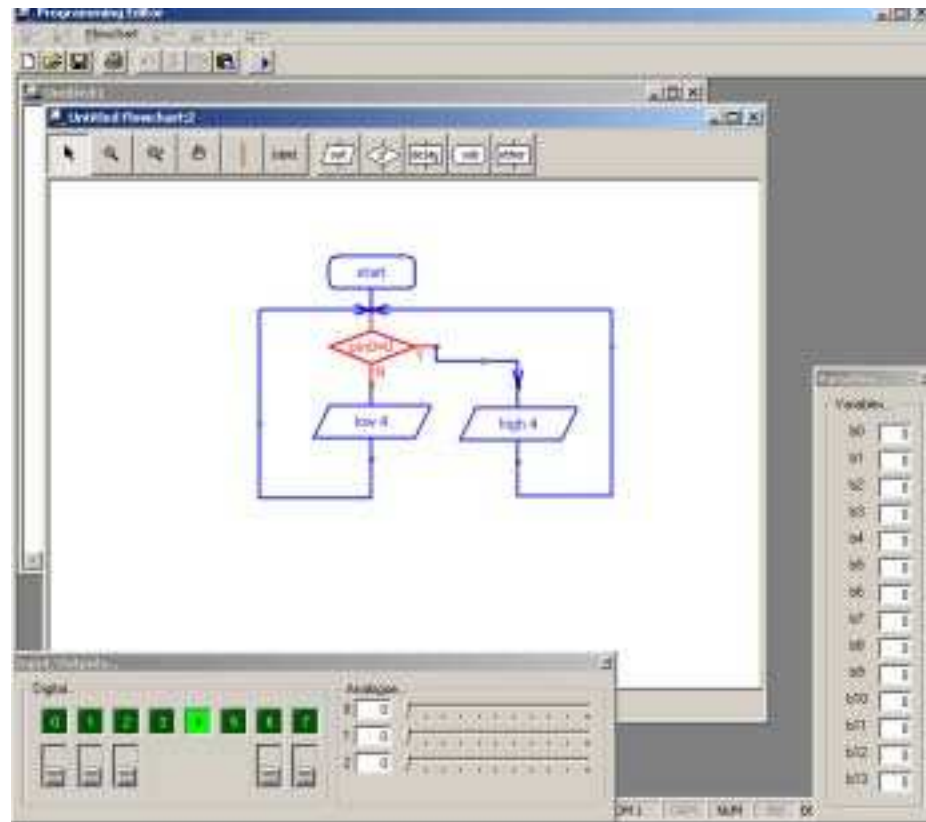

To simulate the flowchart, click 'Simulate' from the Flowchart menu. The program will then start to run on-screen.

As the program runs each cell is highlighted red as it is carried out. The 'Inputs/Outputs' and 'Variables' windows also appear when a simulation is being carried out. To adjust the input values click the on-screen switch (shown beneath the output LED) or slide the analogue input slider.

The time delay between shapes can be adjusted via the Flowchart options (View>Options>Flowchart menu).

Note that certain commands have no on-screen simulation equivalent feature. In this case the command is simply ignored as the flowchart runs.

Downloading Flowcharts

Flowcharts are not directly downloaded to the microcontroller. First the flowchart is converted into a BASIC program, which is then downloaded.

To convert a program select 'Convert' from the Flowchart menu. The BASIC program for downloading will then be created.

Shapes that are not connected to the 'start' or 'sub' shapes in the flowchart are ignored when the conversion takes place. The conversion will stop if an unconnected shape is found. Therefore always use a 'stop' shape or line to complete the flowchart before simulation or conversion.

Note that it is possible to quickly convert and then download a flowchart by pressing the shortcut key <F5> twice.

Using Symbols

Inputs, Outputs and Variables can all be renamed using the 'Symbol Table' from the Flowchart menu. When a symbol is renamed the new name appears in the drop-down menus on the edit bar. Note that you should not use commands (e.g. switch or sound) as a symbol as this will generate errors in your converted BASIC program.

Saving and Printing Flowcharts

Flowcharts can be saved, printed and exported as graphic files (for adding to word processor documents) via the File menu. Flowcharts can also be copied to the Windows clipboard (for pasting into other applications) via the Edit menu.

SECTION 4

PROGRAMMING - BASIC

Programming in BASIC is more powerful than using flowcharts. This is because BASIC contains more commands, eg. for...next loops, which cannot be used with the graphical flowchart methods. However you have to be more accurate in your 'typing' as no spelling mistakes are allowed!

The following program is a sample BASIC program which switches output 0 on and off every second. When you download the program an LED connected to output 0 would flash on and off every second..

```
main:
    high 0
    pause 1000
    low 0
    wait 1
    goto main
```

This program uses the **high** and **low** commands to control output pin 0, and uses the **pause** and **wait** commands to make a delay. Wait uses whole second units, whilst pause uses 1 millisecond (ms) units (1000 ms = 1 second). Therefore in this program both the delays are the same, just written in different ways.

The last **goto main** command makes the program 'jump' back to the label **main:** at the start of the program. This means the program loops forever. Note that the first time the label is used it must be followed by the colon (:) symbol. This tells the computer the word is a new label.

Detailed instructions:

1. Connect the PICAXE cable to the computer serial port. Note which port it is connected to (normally labelled COM1 or COM2).
1. Start the Programming Editor software.
2. Select View>Options to select the Options screen (this may automatically appear).
3. Click on the 'Mode' tab and select PICAXE-08
4. Click on the 'Serial Port' tab and select the serial port that the PICAXE cable is connected to. Click 'OK'
5. Type in the following program:

```
main:
    high 0
    pause 1000
    low 0
    wait 1
    goto main
```

(NB note the colon (:) directly after the label 'main' and the spaces between the commands and numbers)

6. Make sure the PICAXE circuit is connected to the serial cable, and that the batteries are connected.
7. Select PICAXE>Run. A download bar should appear as the program downloads. When the download is complete the program should start running automatically – the LED on output 0 should flash on and off every second.

Programming Editor Software Reminders:

Toolbar short-cuts:



To download/run a BASIC program:

1. Check the download cable is connected to the PICAXE and the computer's serial port
2. Check that the battery is connected to the PICAXE
3. Make sure the Programming Editor software is in the correct mode (look for 'PICAXE-08' in the statusbar at the bottom left of the screen).
4. Click **PICAXE>Run** (or the toolbar icon) (or press the shortcut key F5)

To save a program/flowchart:

1. Click **File - Save As...** (or the toolbar icon)
2. Type in a filename
3. Click <OK>

To open a saved program/flowchart:

1. Click **File - Open...** (or the toolbar icon)
2. Select the file type (BASIC or flowchart)
3. Select a filename from the list by clicking on it
4. Click <OK>

To start a new BASIC program:

1. Click **File - New**

To start a new flowchart:

1. Click **File - New Flowchart** (or the toolbar icon)

To on-screen simulate a flowchart:

1. Click **Flowchart - Simulate...** (or the toolbar icon)
2. Click on the flowchart to stop the simulation

To convert a flowchart to BASIC:

1. Click **Flowchart - Convert to BASIC...** (or press the shortcut key F5)

To print a program/flowchart:

1. Click **File - Print...** (or the toolbar icon)
2. If you want each program line printed in A BASIC program to have a number, make sure the 'Print Line Numbers' box is checked
3. Click <OK>

BUILDING THE RUDOLF PCB

What you will need:

R1 and R2	10k resistor	(brown black orange gold)
R3	22k resistor	(red red orange gold)
R4-8	330R resistor	(orange orange brown gold)
R9	4k7 resistor	(yellow violet red gold)
LED1 and 2	5mm green LED	
LED3	10mm red LED	
PZ	piezo sounder	
LDR	miniature light dependent resistor	
SW1	miniature 6mm switch	
IC1	8 pin IC socket	
IC1	PICAXE-08M microcontroller	
SOCKET	PICAXE download 3.5mm socket	
BT1	battery clip	
BT1	4.5V (3xAA) battery box	
PCB	printed circuit board	

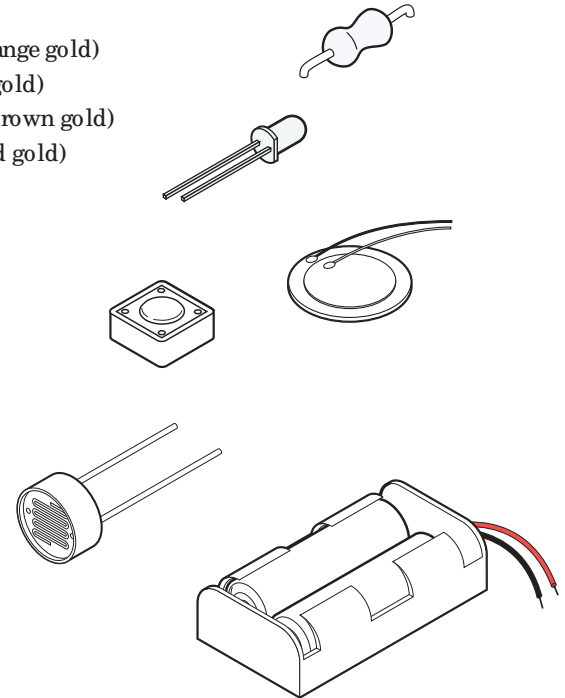

The components C1 and IR are part of the optional infra-red upgrade kit and are not needed unless this upgrade is used.

Tools:

soldering iron and solder
side cutters

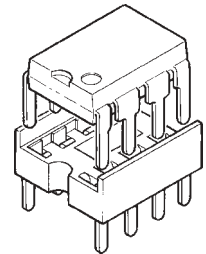

Resistor colour codes

Black	0	0	Black x1	Silver ±10%
Brown	1	1	Brown x10	Gold ±5%
Red	2	2	Red x100	
Orange	3	3	Orange x1000	
Yellow	4	4	Yellow x10,000	
Green	5	5	Green x100,000	
Blue	6	6	Blue x1,000,000	
Violet	7	7		
Grey	8	8		
White	9	9		

Example shown:
 blue, grey, brown, gold
 = 680R ±5%

Soldering the PCB.

The printed circuit board (PCB) is specially manufactured with a 'solder resist' layer to make it simpler to solder. This is the green 'lacquer' layer that covers the tracks so that the solder does not stick to these tracks. However for successful assembly the PCB must be carefully assembled and soldered.

When soldering always make sure the solder iron tip is hot and clean. To test if it is hot enough try to melt a piece of solder on the tip. The solder should melt almost instantly. Then clean off the melted solder by wiping the tip on a damp sponge.

Remember that solder will only 'stick' to hot surfaces. Therefore never melt the solder on the soldering iron tip and then try to 'drop' it onto the joint – this won't work as the joint will be cold and so the solder won't stick.

To successfully solder you must hold the soldering iron in one hand and the solder in the other. Therefore make sure the board is held on the table so it won't move (e.g. use a bulldog clip or get someone else to hold it for you).

Steps to soldering:

- 1) Clean the soldering iron tip on the damp sponge
- 2) Press the soldering iron tip against the pad on the PCB AND the leg of the component. Count to 3 to give the joint time to warm up.
- 3) Keep the soldering iron in position and touch the solder against the joint. Allow enough solder to melt to cover the joint.
- 4) Take the solder away first, then the soldering iron
- 5) Allow the solder to cool for about 5 seconds before trying to move the board.

After each joint is made make sure it does not accidentally 'bridge' across to other joints. However be aware that some solder joints (e.g. on the two sides of the PICAXE download socket) have two wires very close together that are already connected by a track (line) on the PCB. In this case it does not matter if the solder joins together.

Tips!

- 1) Always start with the smallest components like the resistors. Then move onto larger components like the IC socket and then finish with the tall components like capacitors and transistors. Do not try to put all the components in position at once, only do two or three at a time.
- 2) Always make sure that the components lie flat on the board before they are soldered. When using components with long legs like resistors and LEDs, bend the legs so that the component is held firmly in position before soldering.
- 3) Make sure the PICAXE stereo download socket 'snaps' into position flat on the board before it is soldered.
- 4) Make sure that the components that only work one way around (LEDs, diodes, transistors and capacitors) are correctly aligned before soldering (see the marks on the PCB).
- 5) Piezo sounder wires are very thin. Make sure you do not overheat them or they may melt.
- 6) Always thread the battery snap wires down and up through the two thread holes before soldering. This helps make a much stronger joint which is less likely to snap off.

Soldering the PCB

- 1) Very carefully remove the optional 'infra-red upgrade' PCB from between the two 'antlers'. Smooth down any rough spots on the edge of the PCB.
- 2) Place the 4k7 (yellow violet red gold) and two 10k (brown black orange gold) resistors in position. Bend the legs to hold the resistors in position and then solder.
- 3) Place the 22k (red red orange gold) and four 330 (orange orange brown gold) resistors in position. Bend the legs to hold the resistors in position and then solder.
- 4) Push the PICAXE stereo download socket onto the PCB and make sure it clicks into position (so that it lies flat on the board). Solder the five metal square contacts (the five round plastic support post holes do not have to be soldered). Do not worry if the solder joins on the two metal contacts either side of the socket, as they are supposed to be joined anyway.
- 5) Push the IC socket into position. Make sure the notch at one end points up towards the socket. Fold the legs over to hold the socket in position and then solder.
- 6) Solder the LDR and three LEDs into position. Make sure the flat on one side of the LED aligns with the flat marked on the PCB (long leg of LED is positive +).
- 7) Solder the switch in position (note that it only fits one way around).
- 8) Thread the battery clip up through the large hole by the letters '4.5V'. Then solder the black wire in the hole marked BLK and the red wire in the hole marked RED.
- 9) If using a 'plastic cased' piezo so under solder it in place on the left antler. If using a economy flat 'brass' piezo, use 1/2 a sticky pad to stick the piezo sounder (brass side) to the top of the PCB. Thread the wires down through the hole on the right of the antler and back up through the hole marked on the left. Solder the red wire into the bottom hole (nearest the printed circle) and the black wire into the top hole.
- 10) Carefully check the board to make sure there are no missed joints or accidental solder bridges.
- 11) Insert the microcontroller into the socket, ensuring pin1 faces the stereo socket.
- 12) Note the PICAXE-08M chip will require programming before the project will function. See the full rudoIf datasheet for program examples.



The full 40 page rudoIf datasheet (AXE107.pdf) can be downloaded from the datasheets section of www.picaxe.co.uk or from within the Help>PICAXE08 menu of the Programming Editor software.

Testing your circuit.

Step 1 – Check the solder joints.

Check that all the joints are connected to both the pad and the wire, and that the wire is held firmly so that it does not ‘wobble’ when pulled. Also check that the solder does not accidentally bridge between two pads. This is most likely to happen on the LEDs, the LDR and on the piezo. On the stereo socket the two square pads close together on each side can be joined as they are already joined by a track on the board. However they must not be joined to the central round hole.

Step 2 - Check the components.

- 1) Check that the black battery clip wire is in the hole marked ‘BLK’ and the red battery clip wire is in the hole marked ‘RED’
- 2) Check that the PICAXE-08M chip is in the socket correctly, with the dent (showing pin1) closest to the stereo socket.
- 3) Check that the flat edge of the LED is connected to the correct hole on the PCB
- 4) Make sure the brass side of the piezo is stuck down with a sticky pad.
- 5) Check that the socket is correctly soldered, including the middle square pad which is often forgotten by mistake.

Step 3 - Connect the battery.

Check the 3 AA batteries are in the battery box correctly. Connect the battery box to the battery snap and put your finger on the PICAXE chip. If it starts to get hot remove the battery box immediately as there is a problem – most likely that the chip or the battery snap wires are around the wrong way.

Step 4 – Download a program to test ‘nose’ LED.

Connect the cable to the back of the computer and to the PICAXE socket on the PCB. Make sure the cable is pushed fully into the socket on the PCB.

Make sure the software is in the PICAXE-08M mode and the correct serial port is selected (see section 4 of this booklet for more information).

Type in and download the following program:
program like this:

```
main:
    high 0
    wait 1
    low 0
    wait 1
    goto main
```

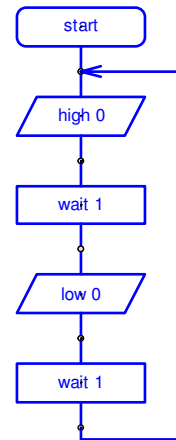

The nose LED should flicker as the program downloads. After the download is complete the LED should flash on and off every second. If the LED does not flash check that it is around the correct way and that the 330R resistors are in the correct positions on the PCB.

If the program does not download check that the 22k, 10k, socket and IC socket are all soldered correctly. Use a multimeter to make sure you are getting 4.5V across the top legs (1 and 8) of the microcontroller. Check that the cable is pushed firmly into the socket and that the correct serial port is selected within the software.

Step 5 – Test the eye LEDs

Repeat the program in step 4, but use high 4 and low 4 instead of high 0 and low 0. This will test the two eye LEDs.

Step 6 – Test the piezo

Type in and download the following program:

```
main:
    play 3,3
    pause 1000
    goto main
```

The piezo should play the ‘rudolf’ tune. If it does not make sure the wires are correctly soldered, that it is stuck on the brass side with a sticky pad (it will not work if ‘hanging loose’). Note that louder tune will be heard with the better quality plastic cased piezo.

Step 7 – Test the switch

Type in and download the following program.

```

main:                                     ` make a label called 'main'
    if input3 = 0 then flash             ` jump if the switch is pushed
    goto main                           ` else loop back around

flash:                                    ` make a label called 'flash'
    high 0                               ` switch output 0 on
    wait 2                               ` wait 2 seconds
    low 0                                 ` switch output 0 off
    goto main                             ` jump back to start
    
```

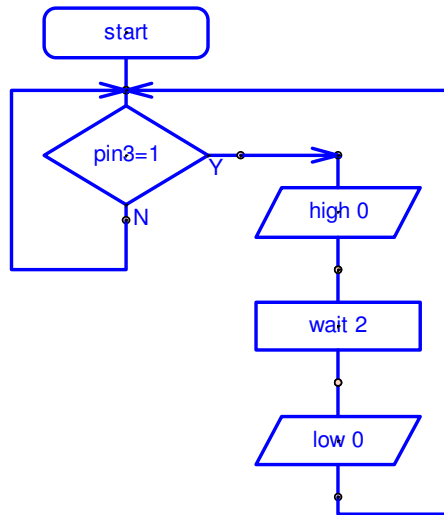

The LED on output 0 should light whenever the switch is pushed. If it does not check that the switch and 10k resistors are correctly soldered.

Step 8 – Test the LDR

Type in and download the following program.

```

main:
  readadc 1,b1
  if b1 > 100 then do4
  if b1 > 50 then do0
  low 0
  low 4
  goto main

do4:
  high 4
  low 0
  goto main

do0:
  high 0
  low 4
  goto main
    
```

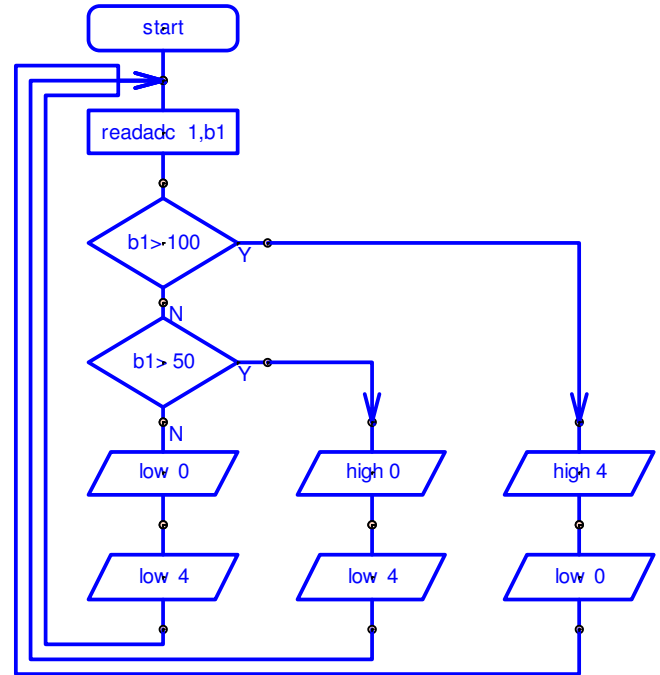

NOTE You may need to change the threshold values if it is dark in the room. e.g. try 60 and 30 instead of 100 and 50

The LEDs should light in different patterns as you raise and lower your hand over the LDR (so that different amounts of light fall on the LDR). If they do not check that the LDR and 10k resistor are correctly soldered.

If all these tests pass, you can be congratulated as you have correctly built and assembled your Rudolf Cyberpet Decoration! It is now time to develop and test your own program to give it a personality!

SECTION 6 - PROGRAM IDEAS.

Now that you have assembled and tested your Rudolf cyberpet, it is time to give it a 'personality' by developing your own program. This program can make the pet react in different ways to the light and push switch sensors.

Included on the next pages are two example programs. These are designed to give you a starting point for your program. You may choose to modify them or to start a completely new program if you prefer.

Be creative!

Your Rudolf cyberpet is your creation so give it an exciting personality! Remember you can download any RTTL mobile phone ring tone by use of the PICAXE-08M Tune Wizard.

Program 1 Explanation

This program has a main loop which scans the switch. When the switch is pushed one of four tunes will play. The tune selected depends on the light level falling on the LDR when the switch is pushed.

Program 2 Explanation

This program is more advanced, and demonstrates how to use the interrupt to stop a tune part way through playing. When the LDR is covered the rudolf tune starts playing. If the switch is pressed whilst the tune is playing the tune will stop.

Program 1

```

' ***** main loop *****
' wait until switch pushed
main:
    if pin3 = 0 then playit
    goto main

' ***** play tune *****
'wait until switch is released
playit:
    pause 10
    if pin3 = 0 then playit

    readadc 1,b1      ' read light level
    'debug b1        ' optional display on screen for testing

' play tune depending on light level
    if b1 > 200 then play_xmas
    if b1 > 150 then play_rudolf
    if b1 > 80 then play_silent

play_jingle:          ' internal tune Jingle Bells
    play 1,3
    goto main

play_silent:         ' internal tune Silent Night
    play 2,3
    goto main

play_rudolf:        ' internal tune Rudolf The Red Nosed Reindeer
    play 3,3
    goto main

play_xmas:          ' external ringtone tune (from Tune Wizard)

' We wish you a Merry Xmas
tune 3, 4, ($22,$27,$67,$69,$67,$66,$24,$24,$24,$29,$69,$6B,$69,$67,
$26,$22,$22,$2B,$6B,$40,$6B,$69,$27,$24,$22,$24,$29,$26,$E7,$22,$27,
$67,$69,$67,$66,$24,$24,$24,$29,$69,$6B,$69,$67,$26,$22,$22,$2B,$6B,
$40,$6B,$69,$27,$24,$22,$24,$29,$26,$A7,$22,$27,$27,$27,$E6,$26,$27,
$26,$24,$E2,$29,$2B,$69,$69,$67,$67,$02,$22,$22,$24,$29,$26,$E7)
    goto main

```

*Note this must be
typed as one long
line in the software*

Program 2

```

' ***** main loop *****
' wait until light level low
main:
    readadc 1,b1      ' read light level
    'debug b1        ' optional display on screen for testing
    if b1 < 100 then playit
    goto main

' ***** play tune *****
playit:

'enable interrupt on switch push
    setint %00000000, %00001000

' play tune
    play 3,3          ' play rudolf
    setint 0, 0       ' ok so interrupt off
    goto main

; ***** interrupt - stop tune if switch pushed *****

interrupt:
    pause 10
    if pin3 = 0 then interrupt
    return

```

ACKNOWLEDGEMENT

This project development was funded by the UK Offshore Oil and Gas Industry.
www.oilandgas.org.uk/education/

(c) Revolution Education Ltd 2002-04
www.rev-ed.co.uk

All rights reserved.

May be photocopied for non-commercial educational use in classrooms in schools and colleges only.

Furby is a trademark of Tiger Electronics Ltd

PICAXE is a trademark of Revolution Education Ltd



APPENDIX A - INFRA-RED UPGRADE (AXE108K)



The Rudolf project PCB is supplied with a small optional 'infra-red' upgrade PCB. When populated with components, this infra-red PCB can be used to remotely control the Rudolf Cyberpet decoration. The components required are supplied in kit AXE-108K.

Note the small push switch on the main Rudolf PCB shares the same input pin (input3) as the infra-red sensor and so should not be used within the main program after connecting the sensor. It is not necessary to remove the switch from the PCB.

Components for main Rudolf PCB

IR	LED020 infra-red receiver
C1	4u7 capacitor

Components for infra-red PCB

R1-3	10k resistor	(brown black orange gold)
R4	330R resistor	(orange orange brown gold)
R-IR	330R resistor	(orange orange brown gold)
LED	5mm yellow LED	
IR	5mm infra-red LED	(may be clear or black in colour)
SW1-3	miniature 6mm switch	
IC1	8 pin IC socket	
IC1	PICAXE-08M microcontroller	
BT1	battery clip	
BT1	4.5V (3xAA) battery box	
PCB	printed circuit board (NB: supplied with main Rudolf Kit)	

Main 'Rudolf PCB' modification

- 1) Place the IR receiver in position IR. Fold the legs by 90 degrees so the receiver is lying flat on the PCB with the curved side up and facing out. Solder in position.
- 2) Place the 4u7 capacitor in position C1, ensuring the positive (+) leg is in the top hole. Solder in position.

Infra-red Upgrade PCB

- 1) Place the infra-red resistor (R-IR) (330 orange orange brown gold) and 330 (orange orange brown gold) resistors in position. Bend the legs to hold the resistors in position and then solder.
- 2) Place the three 10k (brown black orange gold) resistors in position. Bend the legs to hold the resistors in position and then solder.
- 3) Use an off-cut resistor leg to make a wire link in the position LK. This link lies under the 8 pin socket so ensure that the link is lying flat on the PCB before soldering in position.
- 4) Push the IC socket into position. Make sure the notch at one end points up towards the LEDs. Fold the legs over to hold the socket in position and then solder.
- 5) Solder the yellow LED into position LED. Make sure the flat on one side of the LED aligns with the flat marked on the PCB.
- 6) Using a pair of pliers, put a 90 degree bend in the infra-red-LED legs so that it points out from the PCB (see photo on previous page). Solder the infra-red LED into position IR. Make sure the flat on one side of the LED aligns with the flat marked on the PCB.
- 7) Solder the three switches in position (note that they only fit one way around).
- 8) Thread the battery clip up through the large hole by the bottom switch. Then solder the black wire in the hole marked BLK and the red wire in the hole marked RED.
- 9) Carefully check the board to make sure there are no missed joints or accidental solder bridges.
- 10) Note the PICAXE-08M chip will require programming before the project will function. The chip must be programmed on the main rudolf PCB and then moved across to the infra-red PCB, as the infra-red PCB has no programming socket.
- 11) Insert the microcontroller into the socket, ensuring pin1 faces the stereo socket.

Infra-red Upgrade Circuit

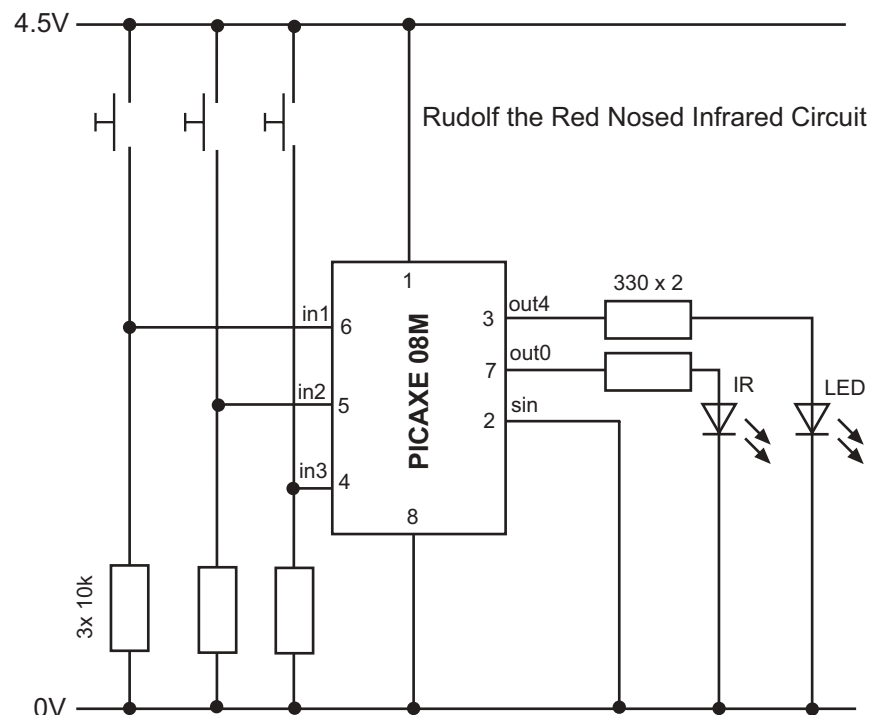

Program Explanation

The infra-red system consists of two programs, one on the infra-red transmitter PCB and one on the main Rudolf PCB. The infra-red transmitter program transmits a different infra-red code for each of the three switches. In the sample program the codes 1,2 and 3 are used, but these can be changed to any number between 0 and 127. To increase reliability in the system the infra-red code is transmitted ten times when the switch is pressed. The yellow LED is lit during transmission for user feedback, as the light from the IR LED is invisible to the human eye.

In the infra-red receiver program the main loop simply waits for a valid infra-red signal. If this is signal is one of the three pre-programmed codes, a tune is played. Note that once the infra-red upgrade has been added the push switch on the main Rudolf PCB (input3) should not be used.

Note it is possible to see if the infra-LED is transmitting by looking at the LED 'end-on' through a web-cam or mobile phone camera. These devices will detect infra-red light and so the LED will visually change colour on the camera screen when transmitting.

Infra-red Transmitter Programmer (infra-red PCB)

(note this must be programmed onto PICAXE-08M by moving the chip onto the main Rudolf PCB)

```
' ***** main loop *****
' loop until switch is pressed
main:
    if pin1 = 1 then tx_1
    if pin2 = 1 then tx_2
    if pin3 = 1 then tx_3
    goto main

tx_1:
    let b1 = 1          ' Code 1
    goto tx_ir

tx_2:
    let b1 = 2          ' Code 2
    goto tx_ir

tx_3:
    let b1 = 3          ' Code 3
    goto tx_ir

'transmit code 10 times for increased reliability
tx_ir:
    high 4              ' yellow LED on
    for b2 = 1 to 10   ' send infrared code 10 times
        infraout 1,b1 ' send code
        pause 45      ' wait 45 milliseconds
    next b2
    low 4               ' LED off
    goto main
```

Infra-red Receiver Programmer (main Rudolf PCB)

(note the infra codes used (1,2,3) must match those used in the transmitter program)

```

' ***** main loop *****
' wait until infrared signal is received
main:
    infrain2

' ***** play tune *****

    'debug infra      ' optional display on screen for testing

' play tune depending on light level
    if infra = 3 then play_xmas
    if infra = 2 then play_rudolf
    if infra = 1 then play_jingle
    goto main

play_jingle:          ' internal tune Jingle Bells
    play 1,3
    goto main

play_silent:         ' internal tune Silent Night
    play 2,3
    goto main

play_rudolf:         ' internal tune Rudolf The Red Nosed Reindeer
    play 3,3
    goto main

play_xmas:           ' external ringtone tune (from Tune Wizard)

' We wish you a Merry Xmas
tune 3, 4, ($22,$27,$67,$69,$67,$66,$24,$24,$24,$29,$69,$6B,$69,$67,
$26,$22,$22,$2B,$6B,$40,$6B,$69,$27,$24,$22,$24,$29,$26,$E7,$22,$27,
$67,$69,$67,$66,$24,$24,$24,$29,$69,$6B,$69,$67,$26,$22,$22,$2B,$6B,
$40,$6B,$69,$27,$24,$22,$24,$29,$26,$A7,$22,$27,$27,$27,$E6,$26,$27,
$26,$24,$E2,$29,$2B,$69,$69,$67,$67,$02,$22,$22,$24,$29,$26,$E7)
    goto main

```

*Note this must be
typed as one long
line in the software*