

SAFETY LIGHT

What is a microcontroller?

A microcontroller is often described as a 'computer-on-a-chip'. It can be used as an 'electronic brain' to control a product, toy or machine.

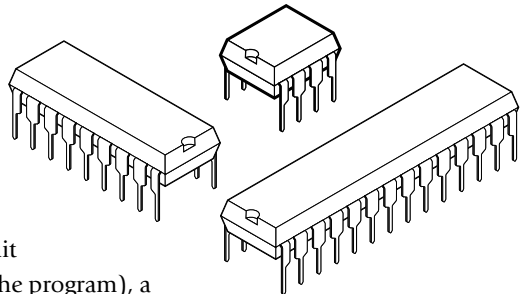

The microcontroller is an integrated circuit ("chip") that contains memory (to store the program), a processor (to process and carry out the program) and input/output pins (to connect switches, sensors and output devices like motors).

Microcontrollers are purchased 'blank' and then programmed with a specific control program. This program is written on a computer and then 'downloaded' into the microcontroller chip. Once programmed the microcontroller is built into a product to make the product more intelligent and easier to use.

Example use of a microcontroller.



The picture above shows a triangular safety light that can be fitted to a belt or bag. It can be used by a person walking or cycling down dark roads to warn car drivers that they are there.

The safety light works by flashing high-brightness Light Emitting Diodes (LEDs) on and off. The microcontroller is the 'brain' of the safety light. Microcontrollers are powerful electronic components that have a memory and can be programmed to switch things on and off in any sequence. The microcontroller in the safety light can switch the LEDs on and off in many different patterns.

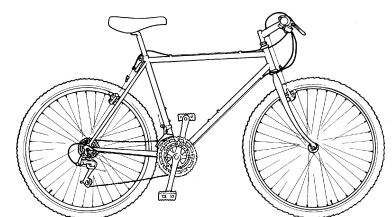

BLOCK DIAGRAMS

The electronic system for a safety light can be drawn as a 'block diagram'.

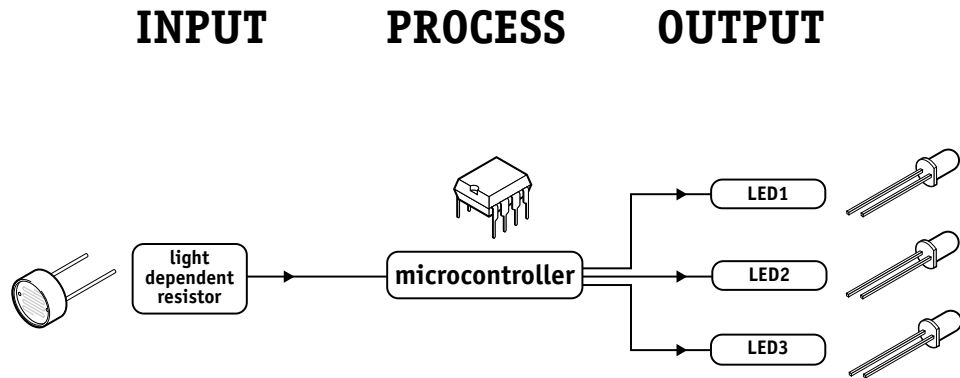

The light sensor (light dependent resistor) can detect changes in light level and is known as an 'input'. The microcontroller then 'decides' how to behave and may then switch the output LEDs on in different patterns.

WHAT IS THE PICAXE SYSTEM?

The microcontrollers used in devices such as safety lights can be difficult to program, as they generally use a complicated programming language called 'assembler code', which can be quite difficult to learn.

The PICAXE system makes the microcontrollers much easier to program. The control sequence can be drawn (and simulated) on the computer as a flowchart, or written in a simpler programming language called BASIC. This makes it much easier to use the microcontroller as the complicated 'assembler code' does not need to be learnt.

A sample BASIC program and flowchart are shown here. In this case both programs do the same thing - flash a light (connected to output 0) on and off every second.

```
main:
    high 0
    wait 1
    low 0
    wait 1
    goto main
```

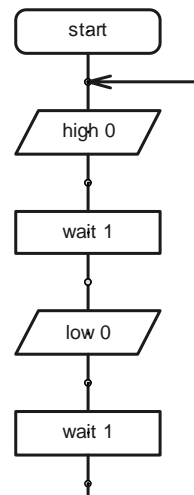

BUILDING YOUR OWN SAFETY LIGHT

Design Brief

Design and make a pedestrian / cyclist safety light. The safety light must be programmed to flash high brightness LEDs on and off.

Design Specification Points

- 1) The design will use a PICAXE-08 microcontroller as its controller.
- 2) The design will include 3 high brightness LEDs.
- 3) The design will be able to optionally react to changes in light levels.

Block Diagram

The block diagram for your safety light may look like this:

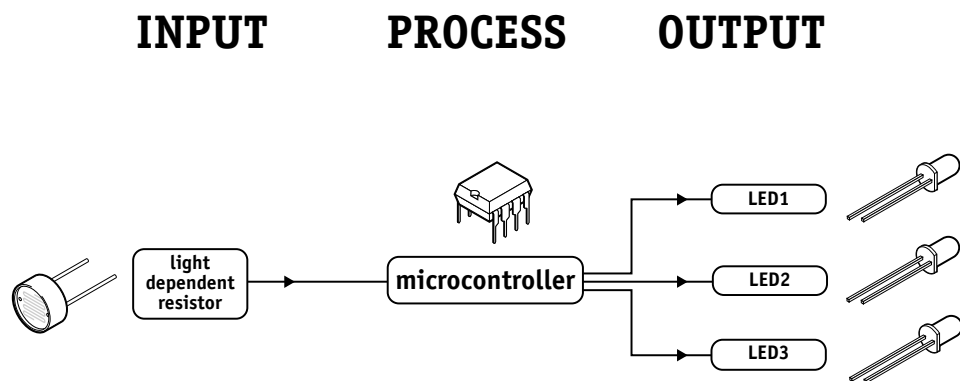

Designing Your Safety Light

The most important thing to think about when using your safety light is the type of casing that is to be used. Are you going to use the triangular project case or make your own?

Other points to consider are:

- 1) What colour, shape and size of LED are you going to use
- 2) What type of batteries are most suitable?
- 3) How is your safety light going to be switched on and off?
- 4) Does your safety light need to be waterproof so it can be used in the rain?

ELECTRONIC COMPONENTS

The main electronic components you may need for your safety light are shown here. The next few pages describe each of these components in more detail, and also provide some programming ideas that may be useful when you are later programming your safety light patterns.

PICAXE-08 microcontroller

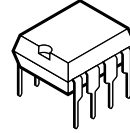

light emitting diode (LED)

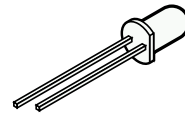

light dependent resistor (LDR)

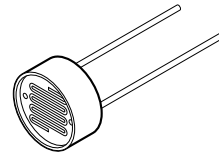

on / off switch

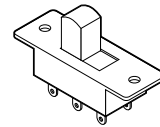

2x AAA battery box

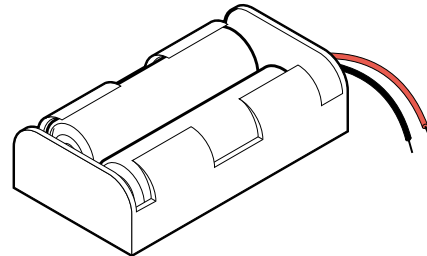

and you will also need

picaxe download socket

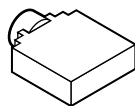

resistors



SECTION 2 - ELECTRONIC COMPONENTS

MICROCONTROLLERS

What is a microcontroller?

A microcontroller is often described as a 'computer-on-a-chip'. It is an integrated circuit that contains memory, processing units, and input/output circuitry in a single unit.

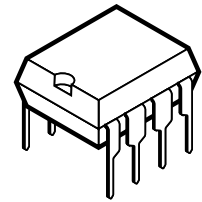

Microcontrollers are purchased 'blank' and then programmed with a specific control program. Once programmed the microcontroller is built into a product to make the product more intelligent and easier to use.

Where are microcontrollers used?

Applications that use microcontrollers include household appliances, alarm systems, medical equipment, vehicle subsystems, and electronic instrumentation. Some modern cars contain over thirty microcontrollers - used in a range of subsystems from engine management to remote locking!

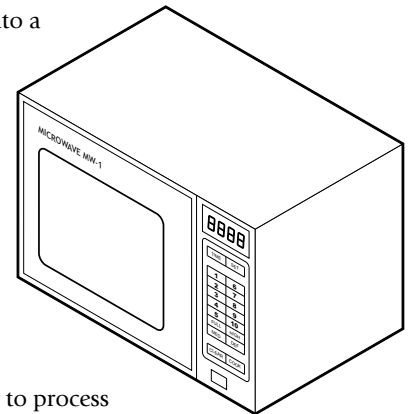

As an example, a microwave oven may use a single microcontroller to process information from the keypad, display user information on the seven segment display, and control the output devices (turntable motor, light, bell and magnetron).

How are microcontrollers used?

Microcontrollers are used as the 'brain' in electronic circuits. These electronic circuits are often drawn visually as a 'block diagram'. For instance a simplified block diagram for the microwave above could be drawn like this:

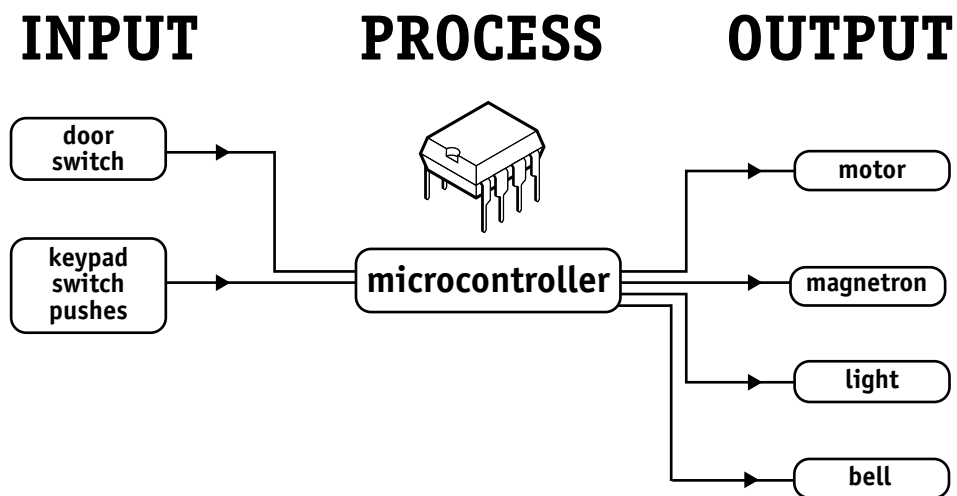

The program for the microcontroller is developed (and tested) on the computer and then downloaded into the microcontroller. Once the program is in the microcontroller it starts to 'run' and carries out the instructions.

How are programs written?

Programs are drawn as flowcharts or typed as 'BASIC' listings. This is explained in the programming section (section 3) later in this booklet.

How is the program transferred to the microcontroller?

The PICAXE-08 microcontroller is programmed by connecting a cable from the serial port at the back of the computer to a socket on the printed circuit board (PCB) beside the microcontroller. This socket (which looks like a headphone socket as found on a portable CD player) connects to two legs of the microcontroller and to 0V from the battery. This allows the computer and the microcontroller to 'talk' to allow a new program to be downloaded into the microcontroller's memory.

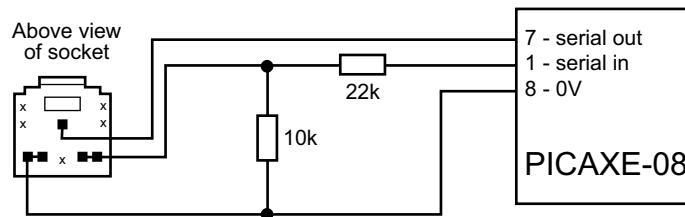

The socket and interfacing circuit is included on every PCB designed to be used with the PICAXE-08 microcontroller. This enables the PICAXE microcontroller to be re-programmed without removing the chip from the PCB - simply connect the cable whenever you want to download a new program!

The circuit diagrams of PICAXE circuits often do not include the components above to make it easier to understand the input/output connections. However the two resistors and the socket are always built onto every PICAXE project board!

Output 0

With the PICAXE-08 system leg 7 has two functions - when a program is being run the leg is known as output 0 and can control outputs like LEDs and motors.

When a program is being downloaded the same leg acts as the 'serial out' pin, 'talking' to the computer. Therefore if you also have an output such as an LED connected to the leg, you will find that the LED will flicker on and off as the program download takes place.

Note:

Most modern computers have two serial ports, normally labelled COM1 and COM2. The Programming Editor software used to create the programs must be configured for the correct serial port - select **View>Options>Serial Port** to select the correct serial port for your machine.

If you are using a new laptop computer it may only have the newer 'USB' type connector. In this case you must buy a USB to serial adapter to use the PICAXE system. These are available from most high street computer stores or online from www.tech-supplies.co.uk (part USB010).

BATTERIES

What is a battery?

A battery is a self-contained source of electronic energy. It is a portable power supply. Batteries contain chemicals that store energy. When connected into a circuit this chemical energy is converted to electrical energy that can then power the circuit.

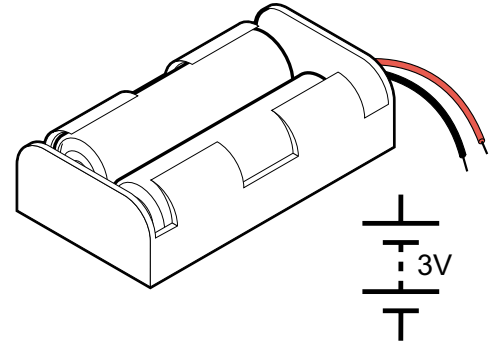

Which battery size should I use?

Batteries come in all sorts of types and sizes. Most battery packs are made up of a number of 'cells', and each cell provides about 1.5V. Therefore 4 cells will generate a 6V battery and 3 cells a 4.5V battery.

As a general rule, the larger the battery the longer it will last (as it contains more chemicals and so will be able to convert more energy). A higher voltage battery does not last longer than a lower voltage battery. Therefore a 6V battery pack made up of 4 AA cells will last much longer than a 9V PP3 battery, as it contains a larger total amount of chemical energy as it is physically larger. Therefore items that require more power to work (e.g. a CD walkman which contains a motor and laser to read the CD's) will always use AA cells rather than PP3 batteries.

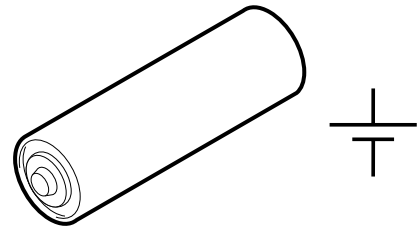

Microcontrollers generally require 3 to 6V to work, and so it is better to use a battery pack made up of two, three or four AAA or AA size cells. Never use a 9V PP3 battery as the 9V supply will damage the microcontroller.

Which battery type should I use?

Different batteries are made of different chemicals. Zinc-carbon batteries are the cheapest, and are quite suitable for many microcontroller circuits. Alkaline batteries are more expensive, but will last much longer when driving devices like motors that require larger currents. Lithium batteries are much more expensive but have a long life, and so are commonly used in computer circuits to provide a clock backup.

Rechargeable batteries can be recharged when they 'run-down'. They are generally made up of nickel and cadmium (Ni-cad) or nickel metal hydroxide (NiMH) chemicals.

Safety!

Never 'short circuit' any battery. Alkaline and rechargeable batteries can provide a very large current, and can get so hot that they will actually melt the battery box if you short circuit them! Always make sure you connect the battery around the correct way (red positive (V+) and black negative (0V or ground)). The microcontroller chip will get hot and be damaged if the battery is connected the wrong way around.

Using battery snaps.

Battery packs are often connected to electronic printed circuit boards by battery snaps or wires. Always ensure you get the red and black wires the correct way around. It is also useful to thread the wires through holes on the board before soldering it in place - this provides a much stronger joint that is less likely to snap off.

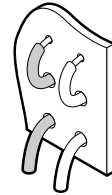

Never accidentally connect a 9V PP3 battery to the battery snap - this will damage the microcontroller, which only works between 3 and 6V.

Soldering to battery boxes.

Some small battery boxes require wires to be soldered to metal contacts on the battery box. In this case you must be very careful not to overheat the metal contact. If the contacts get very hot they will melt the plastic and fall off. A good way of stopping this happening is to ask a friend to hold the metal contact with a pair of small pliers. The pliers will act as a 'heat-sink' and help stop the plastic melting.

LIGHT EMITTING DIODE (LED)

What is an LED?

A Light Emitting Diode (LED) is an electronic component that gives out light when current passes through it. An LED is a special type of diode. A diode is a component that only allows current to flow in one direction. Therefore when using a diode, it must always be connected the correct way around.

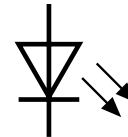
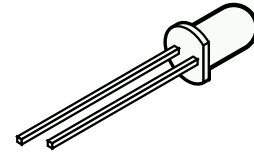

The positive (anode) leg of an LED is longer than the negative (cathode) leg (shown by the bar on the symbol). The negative leg also has a flat edge on the plastic casing of the LED.

What are LEDs used for?

LEDs are mainly used as indicator lights. Red and green LEDs are commonly used on electronic appliances like televisions to show if they are switched on or in 'standby' mode. LEDs are available in many different colours, including red, yellow, green and blue. Special 'ultrabright' LEDs are used in safety warning devices such as the 'flashing lights' used on bicycles. Infra-red LEDs produce infra-red light that cannot be seen by the human eye but can be used in devices such as video remote-controls.

Using LEDs.

LEDs only require a small amount of current to work, which makes them much more efficient than bulbs (this means, for instance, that if powered by batteries the LEDs will light for a much longer time than a bulb would). If too much current is passed through an LED it will be damaged, and so LEDs are normally used together with a 'series' resistor that protects the LED from too much current.

The value of the resistor required depends on the battery voltage used. For a 4.5V battery pack a 330R resistor can be used, and for a 3V battery pack a 120R resistor is appropriate.

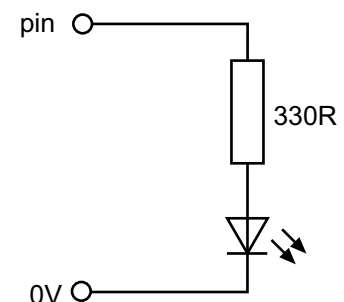

Connecting the LED to a microcontroller.

Because the LED only requires a small amount of current to operate, it can be directly connected between the microcontroller output pin and 0V (with the series protection resistor).

Testing the LED connection.

After connecting the LED it can be tested by a simple program like this:

```
main:
    high 0
    wait 1
    low 0
    wait 1
    goto main
```

This program would switch the LED (connected to output pin 0) on and off every second. If the LED does not work check:

- 1) the LED is connected the correct way around
- 2) the correct resistor is used
- 3) the correct output pin number is being used in the program
- 4) all the solder joints are good

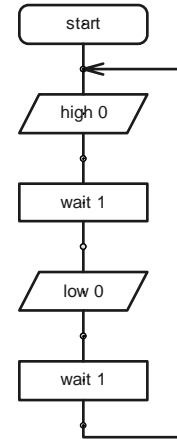

This program flashes the LED connected to output pin 0 on and off 15 times using a BASIC programming technique called a for...next loop (this technique cannot be used with flowcharts). The number of times the code has been repeated is stored in the memory of the PICAXE chip using a 'variable' called b1 (the PICAXE contains 14 variables labelled b0 to b13). A variable is a 'number storage position' inside the microcontroller than the microcontroller can use to store numbers as the program is carried out.

```
main:  for b1 = 1 to 15      \ start a for...next loop
        high 0             \ switch pin 0 high
        pause 500          \ wait for 0.5 second
        low 0              \ switch pin 0 low
        pause 500          \ wait for 0.5 second
    next b1                 \ end of for...next loop

    end                     \ end program
```

Switching more than one LED at once.

Sometimes it is useful to switch more than one LED on or off at the same time. This saves time when lots of high and low commands would have to be used together.

The command that does this is called let pins =

After the equals sign a number is used. Each output pin is given a value, and the number used in the program is the sum of these values.

Pin	2	1	0
Value	4	2	1

Therefore this program switches all of the outputs on, and then all off, and then one on at a time, in sequence.

```

start: low 0          ` switch all outputs off
      low 1
      low 2

main:
  let pins = 7      ` switch all on (4+2+1)
  pause 100         ` wait for 0.1 second
  let pins = 0      ` switch all off
  pause 100         ` wait for 0.1 second
  let pins = 1      ` switch pin 0 on, others off
  pause 100         ` wait for 0.1 second
  let pins = 2      ` switch pin 1 on, others off
  pause 100         ` wait for 0.1 second
  let pins = 4      ` switch pin 2 on, others off
  pause 100         ` wait for 0.1 second
  let pins = 0      ` switch all off
  pause 100         ` wait for 0.1 second
  goto main        ` loop back to start

```

IMPORTANT! The let pins command only works after the pins have been set as outputs. To do this you must use a 'low' command for each pin at the start of the program.

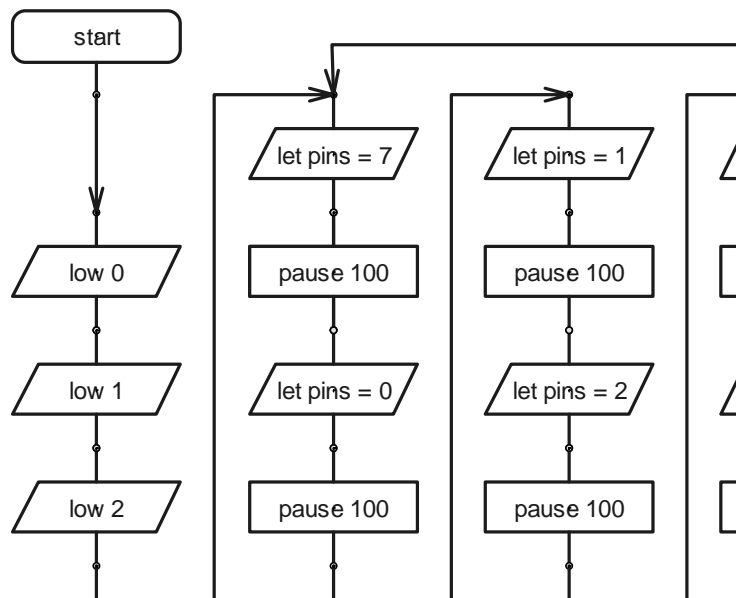

TRIANGULAR CASING (AXE103C)

The triangular casing that can be used to hold the PCB, battery box and LEDs has been specially designed for the safety light project.

The case is made up of three parts - the front of the case, the rear of the case and the belt clip. Note that when the case is supplied these three parts are held together by a piece of 'waste' plastic called the sprue. This is because all three parts

are made at the same time in a mould, by a process called injection moulding. In this process hot molten plastic is injected into a specially shaped mould. When the plastic cools it sets solid into the casing shape. By making all three parts at the same time the manufacturer can reduce costs because only one mould needs to be made and all three parts are made at the same time.

Special transparent red plastic is used to make the case, and 'glitter' is added into the molten plastic before it is injected to give a more reflective surface.



Before using the case the belt clip must be clipped into position on the rear of the case, and then it can be held in place from the inside by a 6mm long 'No.4 self tapping screw'. The PCB is held in place by another 6mm screw as shown in the picture, and then the two halves of the case can be joined together using a 20mm long No. 4 screw.

The case has been carefully designed for the safety light project. Look carefully at the case to see the following features:

- 1) A hole to enable the switch to be used.
- 2) Right angle support posts to hold the PCB in position.
- 3) Posts to support the LEDs.
- 4) Special slots to enable the LED and battery box wires to be threaded between the two halves.
- 5) 'Bump' marker on the inside of the front half to show the 'bottom' of the case.
- 6) 'Lenses' in the corners to help focus the LED light.

LIGHT DEPENDENT RESISTOR (LDR)

What is an LDR?

A Light Dependent Resistor (LDR) is special type of resistor that reacts to changes in light level. The resistance of the LDR changes as different amounts of light fall on the top 'window' of the device. This allows electronic circuits to measure changes in light level.

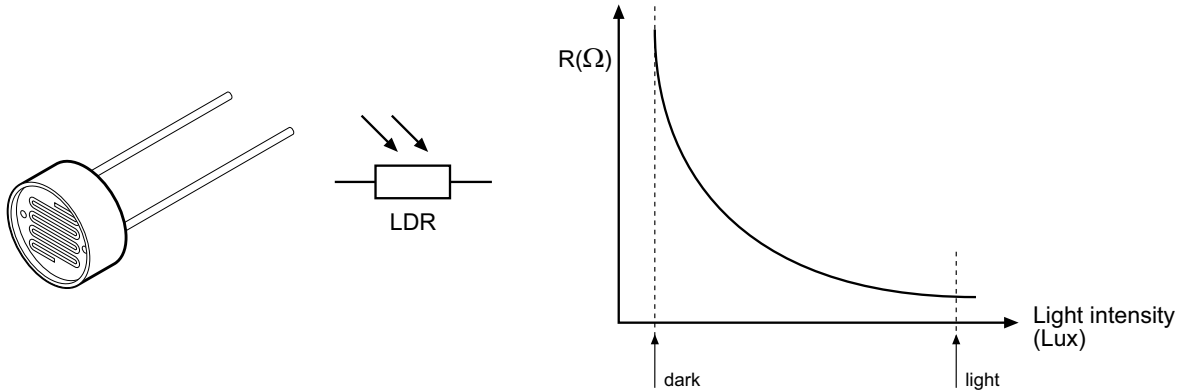

What are LDRs used for?

LDRs are used in automatic street lamps to switch them on at night and off during the day. They are also used within many alarm and toys to measure light levels.

The LDR is a type of **analogue sensor**. An analogue sensor measures a continuous signal such as light, temperature or position (rather than a digital on-off signal like a switch). The analogue sensor provides a varying voltage signal. This voltage signal can be represented by a number in the range 0 and 255 (e.g. very dark = 0, bright light = 255).

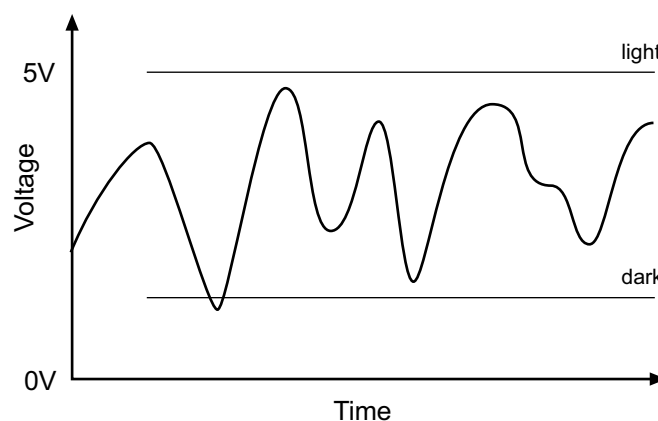

Using LDRs.

A LDR can be used in two ways. The simplest way to use an LDR is as a simple on-off ("digital") switch - when the light level is above a certain value (called the 'threshold value') the LDR will provide an on signal, when the light level is below a certain value the LDR will provide an off signal.

In this case the LDR is used in a potential divider with a standard resistor. The value of the standard resistor sets the 'threshold value'. For miniature LDRs a suitable value is 10k, for larger ORP12 type LDRs 10k is also appropriate. If desired the fixed resistor can be replaced by a variable resistor so that the threshold value can be 'tuned' to different light values.

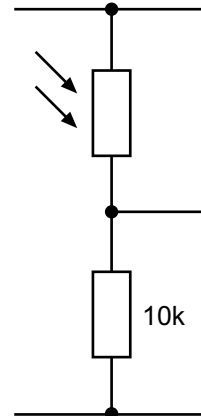

A more complicated way of using the LDR is to measure a number of different light values, so that decisions can be made at varying light levels rather than just one fixed threshold value. A varying value is known as an 'analogue' value, rather than a digital 'on-off' value.

However this more complicated method is not required with the safety light project. Therefore the LDR is used as a normal digital input.

Testing the LDR (digital)

After connecting the LDR it can be tested as a digital switch by a simple program like this:

```

main:
    if input3 is on then dohigh
    low 0
    goto main

dohigh:
    high 0
    goto main
    
```

This program will switch output 0 on and off according to the light level.

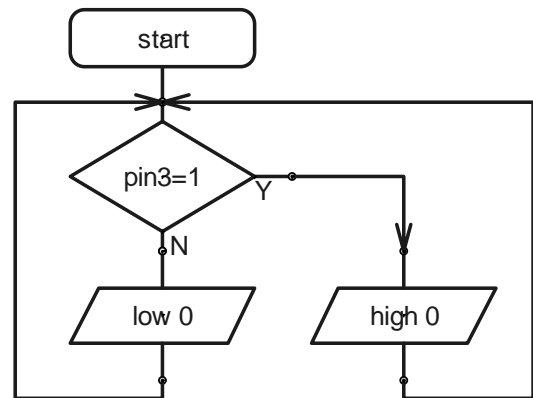

SECTION 3

PROGRAMMING - DRAWING FLOWCHARTS

Flowcharts are a useful tool that allow programs to be drawn graphically to make them easier to understand. The Programming Editor software includes a flowchart editor that allows flowcharts to be drawn on screen. These flowcharts can then be converted to BASIC listings for download into the PICAXE. The flowcharts can also be printed or exported as graphics files for inclusion within project portfolios.

Detailed instructions for drawing/downloading a flowchart:

1. Connect the PICAXE cable to the computer serial port. Note which port it is connected to (normally labelled COM1 or COM2).
2. Start the Programming Editor software.
3. Select View>Options to select the Options screen (this may automatically appear).
4. Click on the 'Mode' tab and select PICAXE-08
5. Click on the 'Serial Port' tab and select the serial port that the PICAXE cable is connected to. Click 'OK'
6. Start a new flowchart by clicking the File>New Flowchart menu.
7. Draw the flowchart by dragging the correct symbols onto the screen, and then using the mouse to draw arrows between the symbols.
8. Once the flowchart is complete it can be converted into a BASIC program by selecting Flowchart>Convert Flowchart to BASIC. The BASIC program can then be downloaded into the PICAXE by clicking the PICAXE>Run menu.
9. To print or save the flowchart, use the File menu options. To export the flowchart as a graphic file, use the File>Export menu. To publish the image in a Word document select file type EME. To publish the flowchart on an internet web page use the GIF file type.

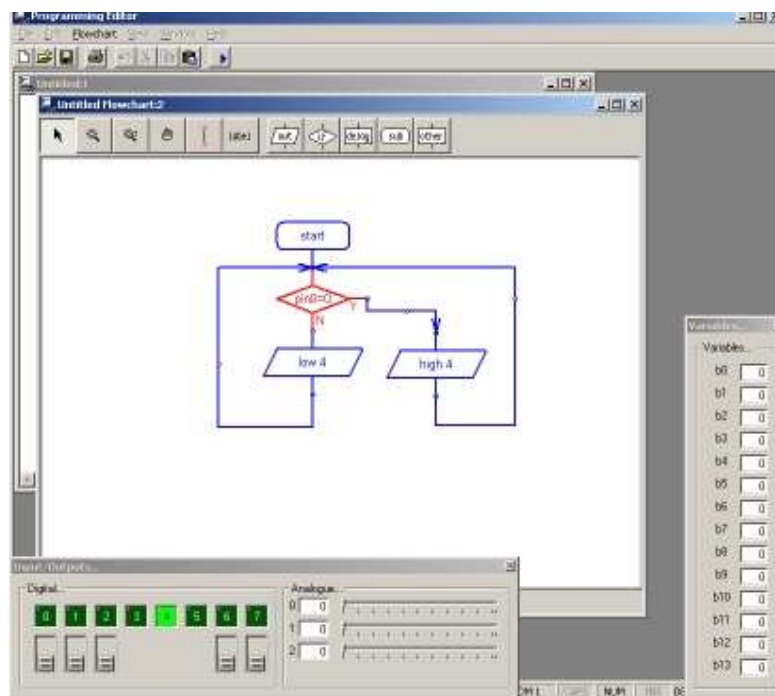

Flowchart Screen

The Flowchart Editor allows flowcharts to be drawn and simulated on-screen. The flowchart can then be automatically converted into a BASIC program for downloading into the microcontroller.

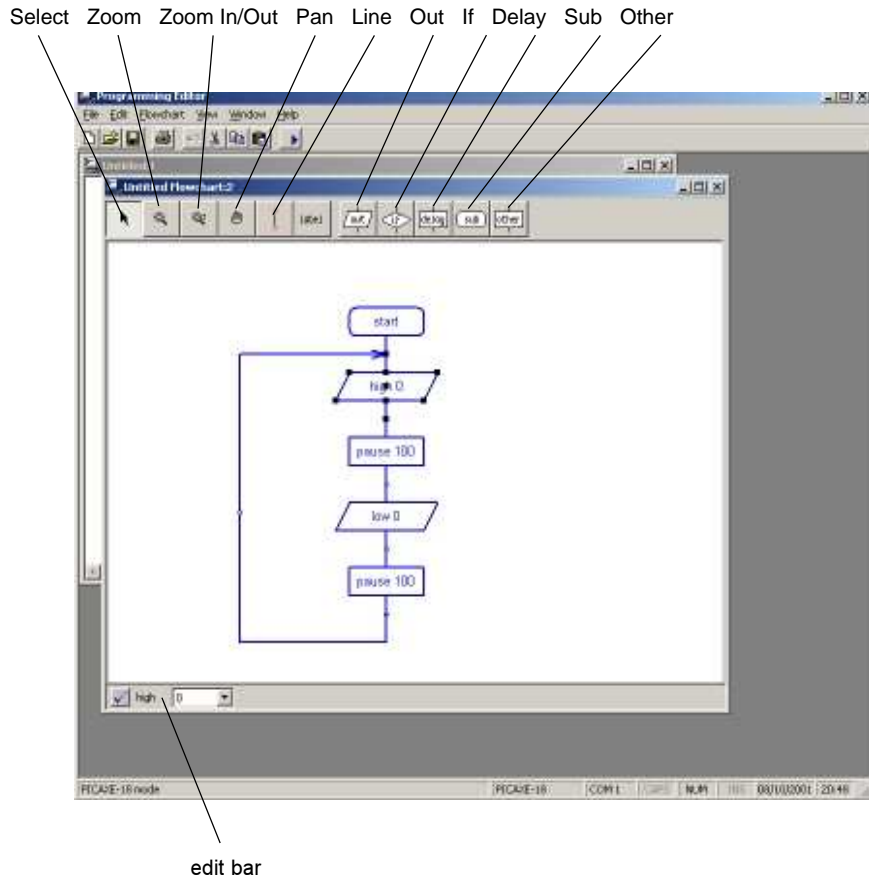

Flowchart Screen

Select Tool

Use this to select and move shapes. When a single shape is selected it's BASIC code can be edited in the edit bar at the bottom of the window.

Zoom

Use to zoom in to an area of the graph. Right click to zoom out.

Zoom In/Out

To zoom in click and move the mouse up. To zoom out click and move the mouse down.

Pan

Use this tool to move around the flowchart.

Line Tool

Use this tool to draw lines between shapes. Corners can be added by clicking once. When the line is near to a shape it will 'snap' to the connection point.

Label Tool

Use this tool to add descriptive labels or titles to the flowchart.

Out / If / Delay / Sub / Other

Click on these buttons to move to the command sub-menu to select commands.

Drawing Flowcharts

To draw a flowchart click on one of the command menu buttons (out / if / delay / sub / other) on the toolbar to move to the appropriate command sub-menu. Select the appropriate command and then click on the screen where the shape is required. Do not try to locate the shape precisely at first – just drop it in the general area and then use the select tool to move the shape to the correct position.

Once the shape is in position click on it so that it is highlighted. The BASIC code for the shape will then appear in the edit bar at the bottom of the screen. Edit the code as required.

For further information about each command see the 'BASIC Commands' help file.

Joining Shapes

Shapes are joined by moving them close together until they 'snap' together. Alternately lines can be drawn between the shapes using the 'line tool' from the main toolbar. Note that it is only possible to join the bottom (side) of shapes to the top of other shapes (you cannot connect lines to lines). Only one line is allowed out of the bottom of each shape.

To enable neat diagrams, corners to the lines can be added by clicking with the mouse. When a line moves close to a connection point it will snap into position and then a click will finish the line.

Lines cannot be moved. If you try to move a line it will be deleted and a new line must be created.

On Screen Simulation

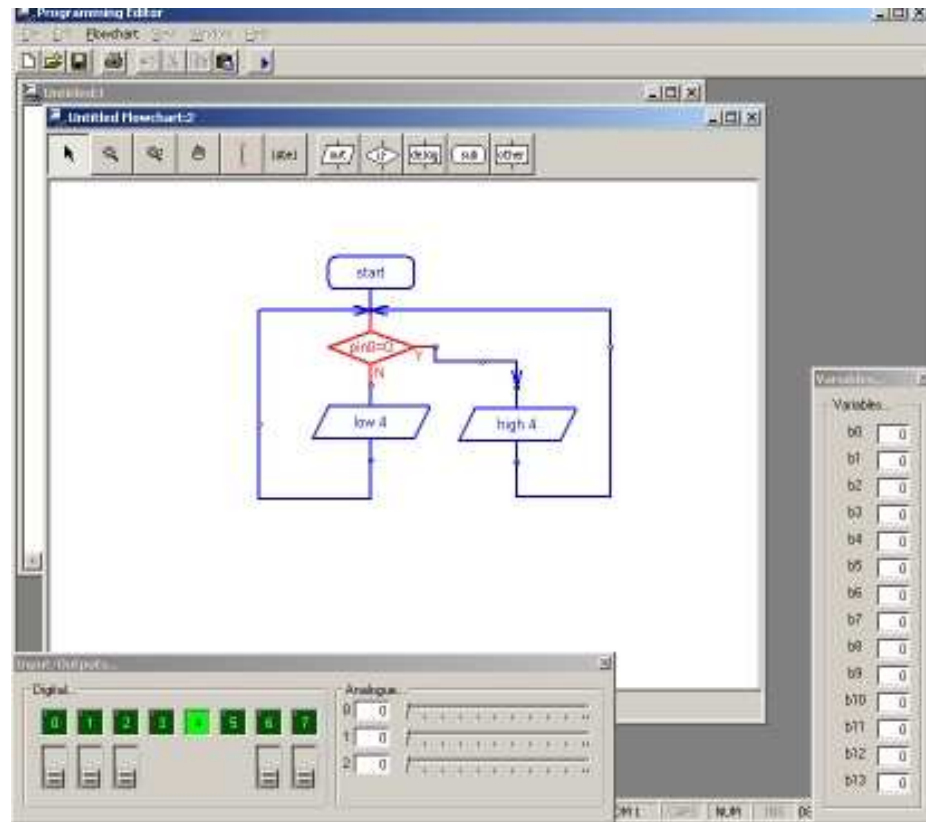

To simulate the flowchart, click 'Simulate' from the Flowchart menu. The program will then start to run on-screen.

As the program runs each cell is highlighted red as it is carried out. The 'Inputs/Outputs' and 'Variables' windows also appear when a simulation is being carried out. To adjust the input values click the on-screen switch (shown beneath the output LED) or slide the analogue input slider.

The time delay between shapes can be adjusted via the Flowchart options (View>Options>Flowchart menu).

Note that certain commands have no on-screen simulation equivalent feature. In this case the command is simply ignored as the flowchart runs.

Downloading Flowcharts

Flowcharts are not directly downloaded to the microcontroller. First the flowchart is converted into a BASIC program, which is then downloaded.

To convert a program select 'Convert' from the Flowchart menu. The BASIC program for downloading will then be created.

Shapes that are not connected to the 'start' or 'sub' shapes in the flowchart are ignored when the conversion takes place. The conversion will stop if an unconnected shape is found. Therefore always use a 'stop' shape or line to complete the flowchart before simulation or conversion.

Note that it is possible to quickly convert and then download a flowchart by pressing the shortcut key <F5> twice.

Using Symbols

Inputs, Outputs and Variables can all be renamed using the 'Symbol Table' from the Flowchart menu. When a symbol is renamed the new name appears in the drop-down menus on the edit bar. Note that you should not use commands (e.g. switch or sound) as a symbol as this will generate errors in your converted BASIC program.

Saving and Printing Flowcharts

Flowcharts can be saved, printed and exported as graphic files (for adding to word processor documents) via the File menu. Flowcharts can also be copied to the Windows clipboard (for pasting into other applications) via the Edit menu.

SECTION 4

PROGRAMMING - BASIC

Programming in BASIC is more powerful than using flowcharts. This is because BASIC contains more commands, eg. for...next loops, which cannot be used with the graphical flowchart methods. However you have to be more accurate in your 'typing' as no spelling mistakes are allowed!

The following program is a sample BASIC program which switches output 0 on and off every second. When you download the program an LED connected to output 0 would flash on and off every second..

```
main:
    high 0
    pause 1000
    low 0
    wait 1
    goto main
```

This program uses the **high** and **low** commands to control output pin 0, and uses the **pause** and **wait** commands to make a delay. Wait uses whole second units, whilst pause uses 1 millisecond (ms) units (1000 ms = 1 second). Therefore in this program both the delays are the same, just written in different ways.

The last **goto main** command makes the program 'jump' back to the label **main:** at the start of the program. This means the program loops forever. Note that the first time the label is used it must be followed by the colon (:) symbol. This tells the computer the word is a new label.

Detailed instructions:

1. Connect the PICAXE cable to the computer serial port. Note which port it is connected to (normally labelled COM1 or COM2).
1. Start the Programming Editor software.
2. Select View>Options to select the Options screen (this may automatically appear).
3. Click on the 'Mode' tab and select PICAXE-08
4. Click on the 'Serial Port' tab and select the serial port that the PICAXE cable is connected to. Click 'OK'
5. Type in the following program:

```
main:
    high 0
    pause 1000
    low 0
    wait 1
    goto main
```

(NB note the colon (:) directly after the label 'main' and the spaces between the commands and numbers)

6. Make sure the PICAXE circuit is connected to the serial cable, and that the batteries are connected.
7. Select PICAXE>Run. A download bar should appear as the program downloads. When the download is complete the program should start running automatically – the LED on output 0 should flash on and off every second.

Programming Editor Software Reminders:

Toolbar short-cuts:



To download/run a BASIC program:

1. Check the download cable is connected to the PICAXE and the computer's serial port
2. Check that the battery is connected to the PICAXE
3. Make sure the Programming Editor software is in the correct mode (look for 'PICAXE-08' in the statusbar at the bottom left of the screen).
4. Click **PICAXE>Run** (or the toolbar icon) (or press the shortcut key F5)

To save a program/flowchart:

1. Click **File - Save As...** (or the toolbar icon)
2. Type in a filename
3. Click <OK>

To open a saved program/flowchart:

1. Click **File - Open...** (or the toolbar icon)
2. Select the file type (BASIC or flowchart)
3. Select a filename from the list by clicking on it
4. Click <OK>

To start a new BASIC program:

1. Click **File - New**

To start a new flowchart:

1. Click **File - New Flowchart** (or the toolbar icon)

To on-screen simulate a flowchart:

1. Click **Flowchart - Simulate...** (or the toolbar icon)
2. Click on the flowchart to stop the simulation

To convert a flowchart to BASIC:

1. Click **Flowchart - Convert to BASIC...** (or press the shortcut key F5)

To print a program/flowchart:

1. Click **File - Print...** (or the toolbar icon)
2. If you want each program line printed in A BASIC program to have a number, make sure the 'Print Line Numbers' box is checked
3. Click <OK>

SECTION 5 - THE SAFETY LIGHT PCB

The safety light project uses a PICAXE-08 microcontroller with three LED outputs. The project also uses a switch to switch the circuit on of off, and may optionally use a Light Dependent Resistor (LDR) so that the safety light can tell whether it is light or dark. The electronic block diagram is shown below.

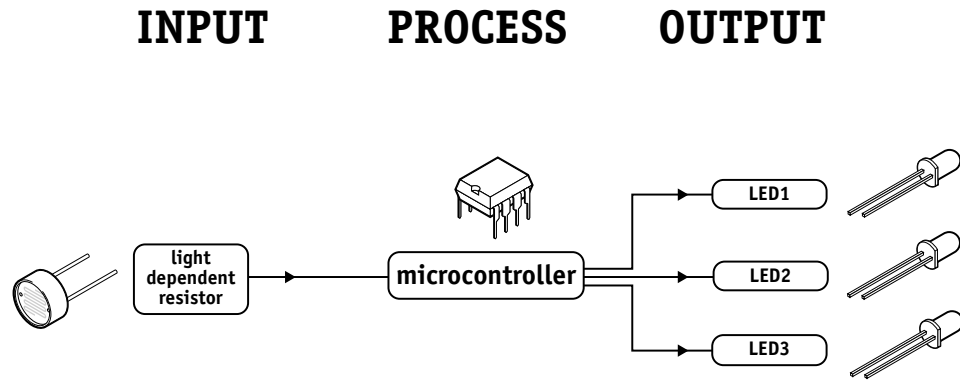

- output - pin0 is connected to LED 0
- output - pin1 is connected to LED 1
- output - pin2 is connected to LED 2
- input - pin3 is connected to the LDR

Remember not to confuse the chip 'leg' number with the input/output pin number!

Circuit Diagram

The circuit diagram for the safety light project is shown below:

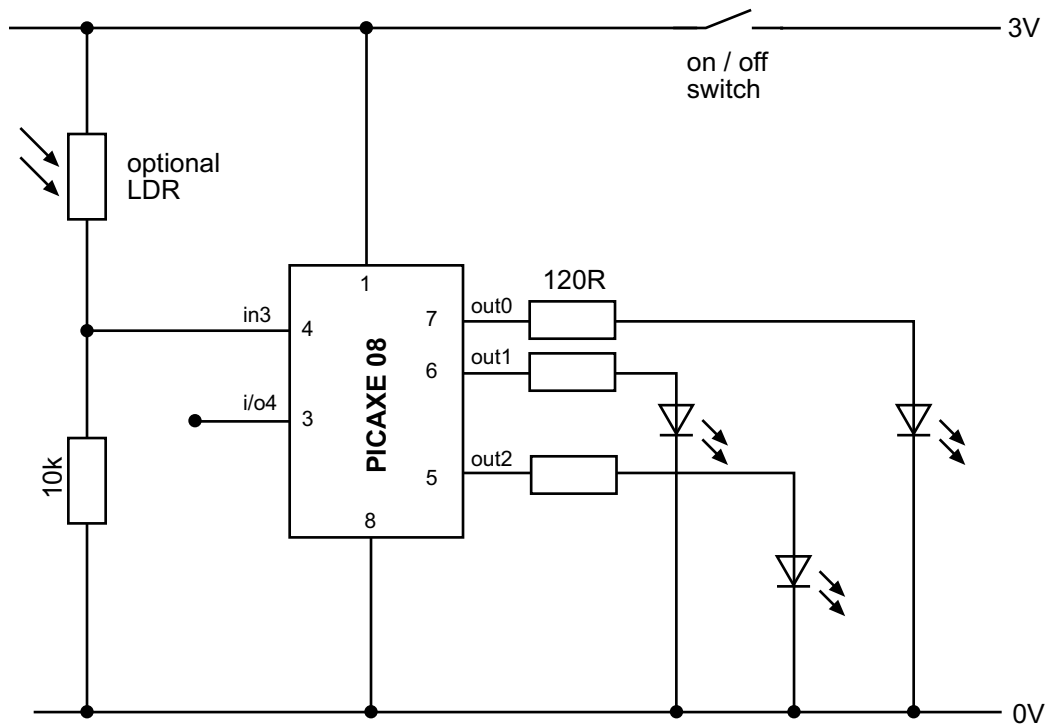

BUILDING THE SAFETY LIGHT PCB

What you will need:

R1, R2, R3	120R resistor	(brown red brown gold)
R4	10k resistor	(brown black orange gold)
R5	22k resistor	(red red orange gold)
R6	10k resistor	(brown black orange gold)
LED1, 2, 3	5mm high brightness LEDs	
SW1	on/off slide switch	
IC1	8 pin IC socket	
IC1	PICAXE-08 microcontroller	
CT1	PICAXE download 3.5mm socket	
BT1	3V (2xAAA) battery box	
PCB	printed circuit board	
single core wire	to connect LEDs and battery box	

optional
LDR miniature light dependent resistor

casing
1 off triangular case and belt clip
2 off No.4 6mm self tapping screw
1 off No.4 16mm self tapping screw

Tools:
soldering iron and solder
side cutters

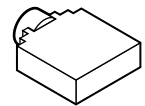
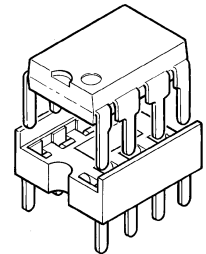
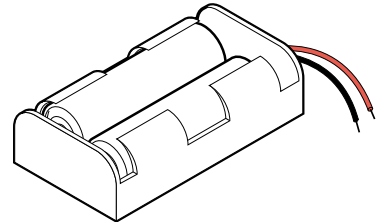
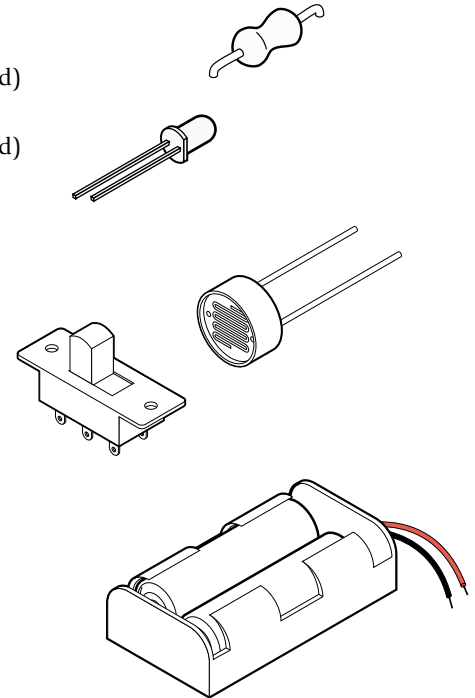

Resistor colour codes		Digit		Multiplier		Tolerance	
Black	0	0	Black x1	Silver ±10%			
Brown	1	1	Brown x10	Gold ±5%			
Red	2	2	Red x100				
Orange	3	3	Orange x1000				
Yellow	4	4	Yellow x10,000				
Green	5	5	Green x100,000				
Blue	6	6	Blue x1,000,000				
Violet	7	7					
Grey	8	8					
White	9	9					

Example shown:
blue, grey, brown, gold
= 680R ±5%

Soldering the PCB.

The printed circuit board (PCB) is specially manufactured with a 'solder resist' layer to make it simpler to solder. This is the green 'lacquer' layer that covers the tracks so that the solder does not stick to these tracks. However for successful assembly the PCB must be carefully assembled and soldered.

When soldering always make sure the solder iron tip is hot and clean. To test if it is hot enough try to melt a piece of solder on the tip. The solder should melt almost instantly. Then clean off the melted solder by wiping the tip on a damp sponge.

Remember that solder will only 'stick' to hot surfaces. Therefore never melt the solder on the soldering iron tip and then try to 'drop' it onto the joint – this won't work as the joint will be cold and so the solder won't stick.

To successfully solder you must hold the soldering iron in one hand and the solder in the other. Therefore make sure the board is held on the table so it won't move (e.g. use a bulldog clip or get someone else to hold it for you).

Steps to soldering:

- 1) Clean the soldering iron tip on the damp sponge
- 2) Press the soldering iron tip against the pad on the PCB AND the leg of the component. Count to 3 to give the joint time to warm up.
- 3) Keep the soldering iron in position and touch the solder against the joint. Allow enough solder to melt to cover the joint.
- 4) Take the solder away first, then the soldering iron
- 5) Allow the solder to cool for about 5 seconds before trying to move the board.

After each joint is made make sure it does not accidentally 'bridge' across to other joints. However be aware that some solder joints (e.g. on the two sides of the PICAXE download socket) have two wires very close together that are already connected by a track (line) on the PCB. In this case it does not matter if the solder joins together.

Tips!

- 1) Always start with the smallest components like the resistors. Then move onto larger components like the IC socket and then finish with the tall components like capacitors and transistors. Do not try to put all the components in position at once, only do two or three at a time.
- 2) Always make sure that the components lie flat on the board before they are soldered. When using components with long legs like resistors and LEDs, bend the legs so that the component is held firmly in position before soldering.
- 3) Make sure the PICAXE stereo download socket 'snaps' into position flat on the board before it is soldered.
- 4) Make sure that the components that only work one way around (LEDs, diodes, transistors and capacitors) are correctly aligned before soldering (see the marks on the PCB).
- 5) Piezo sounder wires are very thin. Make sure you do not overheat them or they may melt.
- 6) Always thread the battery snap wires down and up through the two thread holes before soldering. This helps make a much stronger joint which is less likely to snap off.

With the safety light project all the components are soldered to the board except LED2 and LED3 if you are using the triangular case when these two LEDs are connected by wires.

LED1 is soldered above the pcb on long wires. It is then 'folded' back over the edge of the PCB so that it points downwards instead of upwards.

The optional LDR, if used, is soldered on the track side of the board.

- 1) Place the three 120 (brown red brown gold) resistors in positions R1, R2 and R3 and the 10k (brown black orange gold) resistor in position R6. Bend the legs to hold the resistors in position and then solder.
- 2) Place the 22k (red red orange gold) resistor in position R5 and 10k (brown black orange gold) resistor in position R4. Bend the legs to hold the resistors in position and then solder.
- 3) Push the PICAXE stereo download socket onto the PCB and make sure it clicks into position (so that it lies flat on the board). Solder the five metal square contacts (the five round plastic support post holes do not have to be soldered). Do not worry if the solder joins on the two metal contacts either side of the socket as they are supposed to be joined anyway.
- 4) Push the IC socket into position. Make sure the notch at one end points towards the resistors. Fold the legs over to hold the socket in position and then solder.
- 5) Solder the slide switch in position.
- 6) Position LED1 in position. Make sure the bottom of the LED is level with the top of the switch (ie the LED is about 6mm above the PCB. Solder in position.
- 7) Solder wires to LED2, LED3 and battery BT holes. Note that all the wires can be threaded through the larger holes to create a stronger joint. The wires should be at least 60mm long.
- 8) Solder the battery wires to the battery box, ensuring correct polarity (correct + and - connections). Take care not to overheat the metal contacts on the battery box or they will melt away from the plastic case.
- 9) Solder the LED wires to the LEDs, making sure the legs are soldered the correct way round. Before doing this fold the legs of the LEDs in half and solder to the bottom half of the leg. This will make sure the LEDs fit in the case correctly.
- 10) If desired, solder the optional miniature LDR on the TRACK side of the board. It should be left raised on legs approximately 5mm above the board.
- 11) Carefully check the board to make sure there are no missed joints or accidental solder bridges.
- 12) Insert the microcontroller into the socket, ensuring pin1 faces the resistors.

Fitting in the case.

The case is a tight fit! Do not put your PCB in the case until you are sure it works!

- 1) Screw the belt clip to the back of the case using a 6mm screw.
- 2) Place the PCB in position and use the 6mm screw to hold it in place.
- 3) Lay the battery box in position. Note that you might have to 'twist' the battery clips sideways to enable it to fit correctly.
- 4) Make sure the wires are in the slots and then put the LEDs in position
- 5) Use the 20mm screw to tighten the two halves of the case together.

Testing your circuit.

Step 1 – Check the solder joints.

Check that all the joints are connected to both the pad and the wire, and that the wire is held firmly so that it does not 'wobble' when pulled. Also check that the solder does not accidentally bridge between two pads. This is most likely to happen on the LEDs and the LDR. On the stereo socket the two square pads close together on each side can be joined as they are already joined by a track on the board. However they must not be joined to the central round hole.

Step 2 - Check the components.

- 1) Check that the black battery clip wire is in the hole marked '0V' and the red battery clip wire is in the hole marked 'V+'
- 2) Check that the PICAXE-08 chip is in the socket correctly, with the dent (showing pin1) closest to the stereo socket.
- 3) Check that the flat edge of the LEDs is connected to the correct hole on the PCB.
- 4) Check that the socket is correctly soldered, including the middle square pad which is often forgotten by mistake.

Step 3 - Connect the battery.

Check the 2 AAA batteries are in the battery box correctly. Slide the switch on and then put your finger on the PICAXE chip. If it starts to get hot slide the switch off immediately as there is a problem – most likely that the chip or the battery wires are around the wrong way.

Step 4 – Download a program to test LED 0.

Connect the cable to the back of the computer and to the PICAXE socket on the PCB. Make sure the cable is pushed fully into the socket on the PCB.

Make sure the software is in the PICAXE-08 mode and the correct serial port is selected (see section 4 of this booklet for more information).

Type in and download the following program:
program like this:

```
main:
    high 0
    wait 1
    low 0
    wait 1
    goto main
```

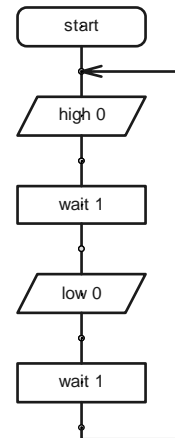

The LED should flicker as the program downloads. After the download is complete the LED should flash on and off every second. If the LED does not flash check that it is around the correct way and that the 120R resistors are in the correct positions on the PCB.

If the program does not download check that the 22k, 10k, socket and IC socket are all soldered correctly. Use a multimeter to make sure you are getting 3V across the top legs (1 and 8) of the microcontroller. Check that the cable is pushed firmly into the socket and that the correct serial port is selected within the software.

Step 5 – Test LED 1.

Repeat the program in step 4, but use high 1 and low 1 instead of high 0 and low 0. This will test the other LED.

Step 6 – Test LED 2.

Repeat the program in step 4, but use high 4 and low 4 instead of high 2 and low 2. This will test the other LED.

Step 7 – Test the (optional) LDR.

Type in and download the following program.

```

main:
    if pin3 = 1 then LEDon
    low 0
    goto main

LEDon:
    high 0
    goto main
  
```

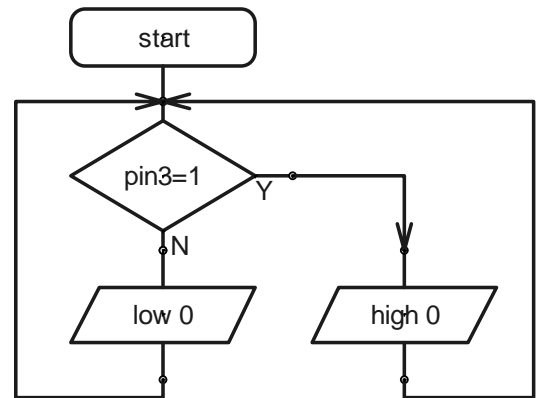

The LED should light as you raise and lower your hand over the LDR (so that different amounts of light fall on the LDR). If they do not check that the LDR and 1k resistor are correctly soldered.

If all these tests pass, you can be congratulated as you have correctly built and assembled your Safety Light! It is now time to develop and test your own program!

SECTION 6 - PROGRAM IDEAS.

Now that you have assembled and tested your Safety Light, it is time to develop your own program. This program can make different LED patterns appear on the safety light.

Included on the next pages are two example programs. These are designed to give you a starting point for your program. You may choose to modify them or to start a completely new program if you prefer.

Be creative!

See how many different light patterns you can create!

Program 1 Explanation

This program has a main loop which flashes the LEDs on and off fairly slowly.

If the LDR light sensor is in the dark the LEDs will flash on and off much more quickly.

Program 2 Explanation

This program is much more advanced. It uses a number of for...next loop to create a number of different patterns.

Program 1

```
` ***** slow loop *****
slow:
    high 0 ` LEDs on
    high 1
    high 2
    pause 500` wait 0.5 second

    ` if light value low then goto fast
    if pin3 = 0 then fast

    low 0 ` LEDs off
    low 1
    low 2
    pause 500` wait 0.5 second

    ` if light value low then goto fast
    if pin3 = 0 then fast

    goto slow

` ***** fast loop *****
fast:
    high 0 ` LEDs on
    high 1
    high 2
    pause 100` wait 0.1 second

    ` if light value high then goto slow
    if pin3 = 1 then slow

    low 0 ` LEDs off
    low 1
    low 2
    pause 100` wait 0.1 second

    ` if light value high then goto slow
    if pin3 = 1 then slow

    goto fast
```

Program 2

```
start:
' make pins 0-2 outputs
    low 0
    low 1
    low 2

main:
' all on - all off 20 times
    for b1 = 1 to 20
        let pins = 7
        pause 100
        let pins = 0
        pause 100
    next b1

' in circles 20 times
    for b1 = 1 to 20
        let pins = 1
        pause 100
        let pins = 2
        pause 100
        let pins = 4
        pause 100
    next b1

' flashing in circles 20 times
    for b1 = 1 to 20
        let pins = 1
        pause 100
        let pins = 0
        pause 100
        let pins = 2
        pause 100
        let pins = 0
        pause 100
        let pins = 4
        pause 100
        let pins = 0
        pause 100
        let pins = 2
        pause 100
        let pins = 0
        pause 100
    next b1

'loop back to start
    goto main
```

ACKNOWLEDGEMENT

This project development was funded by the UK Offshore Oil and Gas Industry.
www.oilandgas.org.uk/education/

(c) Revolution Education Ltd 2002
www.rev-ed.co.uk

All rights reserved.

May be photocopied for non-commercial educational use in classrooms in schools and colleges only.

PICAXE is a trademark of Revolution Education Ltd

