

PICAXE RADIO CONTROL SERVO UPGRADE

Order Codes:

AXE030 PICAXE Radio Control Servo Upgrade Pack

Contents:

- 10-pin header
- radio control servo
- external power supply cable (28 use only)
- 16-pin 330R dual inline resistor (28 use only)

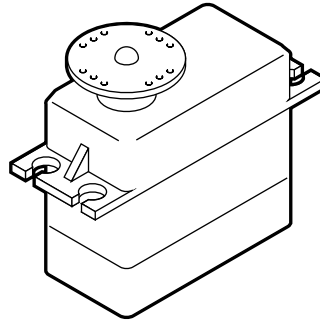

Instructions (PICAXE-28 project board)

Solder the 10-pin header beside the existing output headers.

Remove the ULN2803A darlington driver IC. Replace with the DIL resistor at the top of the socket. The bottom two pins of the socket are left empty.

Remove the jumper link from header E and connect a separate 6V supply for the servos.

When connecting a servo to one of the outputs, ensure the black wire is at the outer side of the interface. In the diagram below the servo is connected to output pin 0.

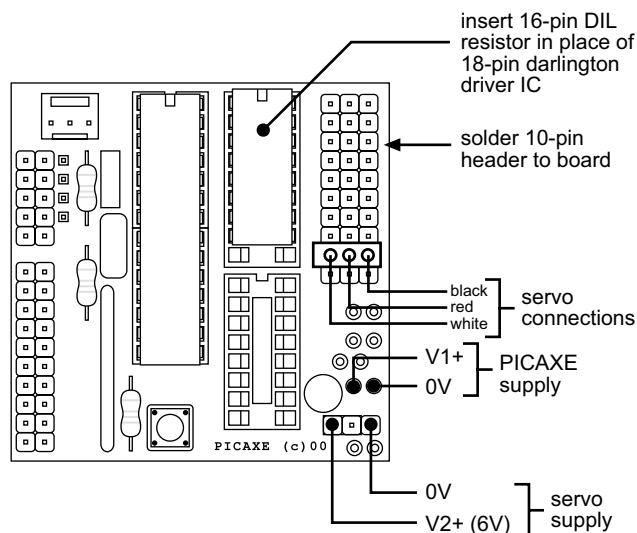

Warning! - Servos generate a lot of electrical noise. The PICAXE microcontrollers WILL NOT run correctly if a single power supply is used. This is because the electrical noise will disrupt the operation of the PICAXE microcontroller, constantly resetting it. If noise affects your circuit try soldering a large electrolytic capacitor as close as possible to the microcontroller power pins.

Instructions (PICAXE-18 standard project board)

Snap off 3 pins from the 10 way header, and solder in the 3 holes beside the PWR V+ connection. Separate the two power supplies (as explained in the project board datasheet) by removing the 120R resistor above the capacitor. The servo can then be connected to output 0 by the 3 pin header (white wire facing up, by the word PIC).

Circuit

The servo has just three connection wires: red, black and white (or yellow). The red wire is the 6V supply, the black wire is the 0V supply, and the white wire is for the positioning signal.

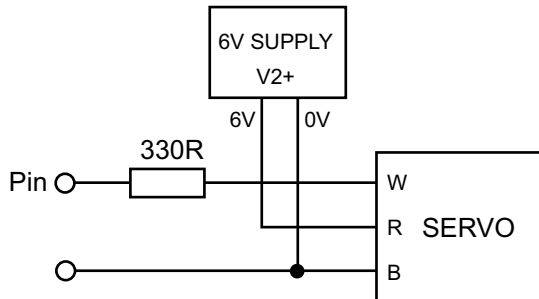

The positioning signal is a pulse between 0.75 and 2.25 milliseconds (ms) long, repeated about every 18ms (so there are roughly 50 pulses per second). With a 0.75ms pulse the servo moves to one end of its range, and with a 2.25ms pulse the servo moves to the other. Therefore, with a 1.5ms pulse, the servo will move to the central position. If the pulses are stopped the servo will move freely to any position.

Unfortunately servos require a large current (up to 1A) and also introduce a large amount of noise on to the power rail. Therefore in most cases the servo should be powered from a separate power supply, as shown below. Remember that when using two power supplies the two 0V rails must be joined to provide a common reference point.

```

loop:  servo 0,75           ` move servo to one end
      pause 2000           ` wait 2 seconds
      servo 0,150          ` move servo to centre
      pause 2000           ` wait 2 seconds
      servo 0,225          ` move servo to other end
      pause 2000           ` wait 2 seconds
      goto loop            ` loop back to start

```

For more information, please refer to the servo command in BASIC Commands help file.