

Boost from Low Input Voltage to 3.3-5.0V!



3 Watt VUP Series

Minimum Size, Step-Up DC-DC Converter

Input: 1.3V to 4.2V **Output: 3.3V (3.3V to 5.0V)**

Voltage can be optionally set with external resistors. (Ex.: 3.3V, 4.0V, 5.0V)

- Efficiency 86% (at 0.7A load)
- Efficiency 90% (at 0.5A load)
- Latest Technology, Synchronous Rectification Circuit
- Non-Isolated Type Converter
- Wide Input Voltage Range
- Remote ON/OFF Control
- Adjustable Output Voltage
- High Reliability, High Performance
- Operating Temp Range
-20°C to +70°C
(Temp Derating Required)
- RoHS Compliance

Models VUP Series	Input V Vdc	Output V Vdc	Output I A	Line Reg. %(typ.)	Load Reg. %(typ.)	Ripple Noise mVpp(typ.)	Efficiency %(typ.)
VUP-3.3S0R9	1.3-(4.2)	3.3	0-0.9			10	82
VUP-3.3S0R9D							(86)

Note 1: Regarding this converter, for normal operation the output voltage needs to be higher than that of the input voltage.

Input voltage range at 3.3V output ----- 1.3V-2.8V

Input voltage range at 5.0V output ----- 1.3V-4.2V

Note 2: Ripple noise, efficiency value is when input voltage is at 2.5V.

Note 3: Efficiency () value is at 0.7A load.

Note 4: Ripple noise is measured at 20MHz bandwidth.

Note 5: Depending on the ambient air temp conditions, air flow cooling is required.

Note 6: For this product, there is a limit of max. output current depending on the input voltage. Refer to the data sheet.

<Outline>

VUP-3.3S0R9 (SIP type)

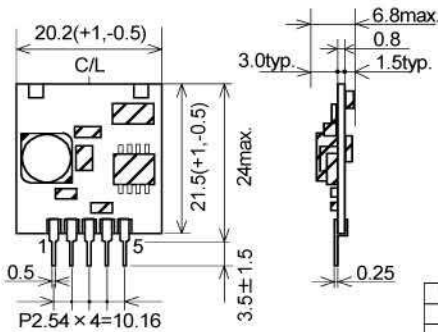

Pin	Function
1	ON/OFF
2	Vin
3	GND
4	Vout
5	V.ADJ

Weight: 3g typ.
Units: mm

VUP-3.3S0R9D (DIP type)

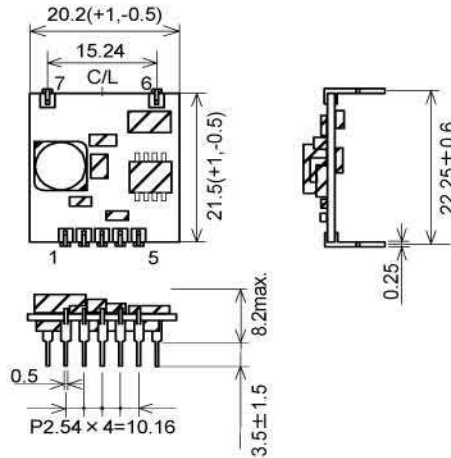

Pin	Function
1	ON/OFF
2	Vin
3	GND
4	Vout
5	V.ADJ
6	Test pin *1
7	NC

Weight: 3g typ.
Units: mm

*1 This pin is for testing.
Do not connect to anywhere.

<Standard Connection Diagram>

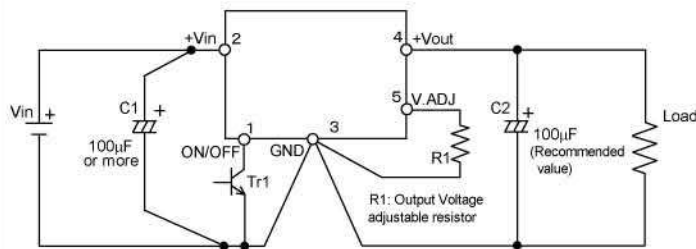

Tr1
OFF → Output ON
ON → Output OFF
ON: Between 1pin and 3pin
(-0.3 to +0.4V)

- Note!
This catalogue is an outline of the products.
When designing, be sure to refer to the data sheets.

- When not using the ON/OFF control, keep the ON/OFF pin open.
- When not adjusting the output, keep the V.ADJ pin open.
- Low impedance product should be used for the input capacitor (C1), and put close to the pins (2pin, 3pin).
- Be sure to use an input and output capacitor. Output capacitor: ESR• ≤5mΩ.