

VSV-m3, m6, m8 is an ultra small size (15×24×4mm size) and light weight (2.6g) step-down DC-DC converter, which has achieved maximum 26W. Since it can correspond from ultra low output voltage of 1.0V, it can be used for the latest DSP, ASIC applications. Due to high-speed response, high efficiency by synchronous rectification circuit technology, saving space by no external components, an excellent performance beyond our common sense has been achieved.

<Features>

- Latest Power-IC adopted
- High-speed Response
- Efficiency 94%, 96%
- ON/OFF Control
- Heat Sink not required
- The Latest Technology, Synchronous Rectification Circuit
- Additional external capacitor not required
- Short-Circuit, Over-Current Protection
- Adjustable Output
- Non-Isolated Type Converter
- Ultra Minimum Size
- Operating Temp. -40°C to +85°C
- High Reliability, High Performance
- RoHs Compliance

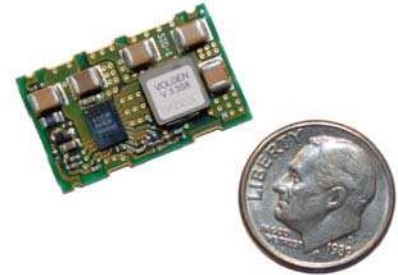

<Model, Rating>

Table 1

Model	Rating Input Voltage Vdc	Rating Output Voltage Vdc	Rating Output Current A	No-Load Input Current mA(typ.)	Ripple Noise mVpp(typ.)	Efficiency %(typ.)	Package Type
VSV-3.3S3R0M	5.0 (3.0-5.5)	3.3 (1.0-3.3)	3	30	30	96	SMD
VSV-3.3S6R0M			6	60	50	94	
VSV-3.3S8R0M			8	70	50	96	

Note 1: Rating input voltage () is the voltage range, and the input voltage needs to be 0.5V or more compared to the output voltage.

Note 2: Rating output voltage () is the adjustable range.

Table 2

<Specification>

	VSV-3.3S3R0M	VSV-3.3S6R0M	VSV-3.3S8R0M	Conditions
Input voltage/range	Refer to Table 1.			
Output voltage accuracy	+3.3V±3%			VAR pin open.
Line regulation	0.5% typ.			For the regulation of Vin=3-5.5
Load regulation	1.0% typ.			For the regulation of Iout=0A-rating
Temperature coefficient	±0.02%/ °C typ.			For the regulation of Ta=-40 to +50°C
Adjustable output range	1.0-3.3V			Refer to table 1
Ripple & Noise	30mVp-p typ.	50mVp-p typ.	50mVp-p typ.	BW=20MH z
Efficiency	96%typ.	94%typ.	96%typ.	
Over-Current Protection	Operates at 105% or more rating load, auto recovery type.			Avoid long-time short-circuit condition.
Over-Voltage Protection	None			Refer to page 3, adjusting voltage setting.
No Load Input Current	30mAtp.	60mAtp.	70mAtp.	Iout=0A
Remote on/off control	Between 5pin(RC)–3pin(S.GND) [Open: Output ON, Short: Output OFF]			Refer to page 4, ON/OFF control.
UVLO start up voltage	2.8V typ.			
UVLO end voltage	2.7V typ.			
P-Good output	At normal output : H, At output dropping : L (0-0.4V Vin=+5V Sinks current=9mA or below)			Refer to page 4, power good output.
Operating temp. range	Operating Temp. -40°C to +85°C			Refer to page 6, temp. derating.
Storage temperature range	Storage Temp. -40°C to +85°C (+125°C at baking)			
Humidity range	20%- 95%R.Hmax. (Ma. Wet-bulb temp. 35°C, non-condensing)			
Cooling condition	Refer to the thermal derating on page 6.			
Vibration	5-10Hz All amplitude 10mm (1 hour in each of 3 directional axes), 10-55Hz acceleration 2G (1 hour in each of 3 directional axes)			
Shock	Acceleration 20G (3 directions, 3 times each), Shocking time 11±5ms			
MTBF	1,000,000 Hrs			
Weight	2.6g typ.			Refer to the outline on page 2 for detail dimensions.
Outline	SMD type W=15 L=24 H=4.0 typ. (mm)			

* Unless otherwise specified, input and output is the rating value and ambient temperature is +25°C.

<Outline>

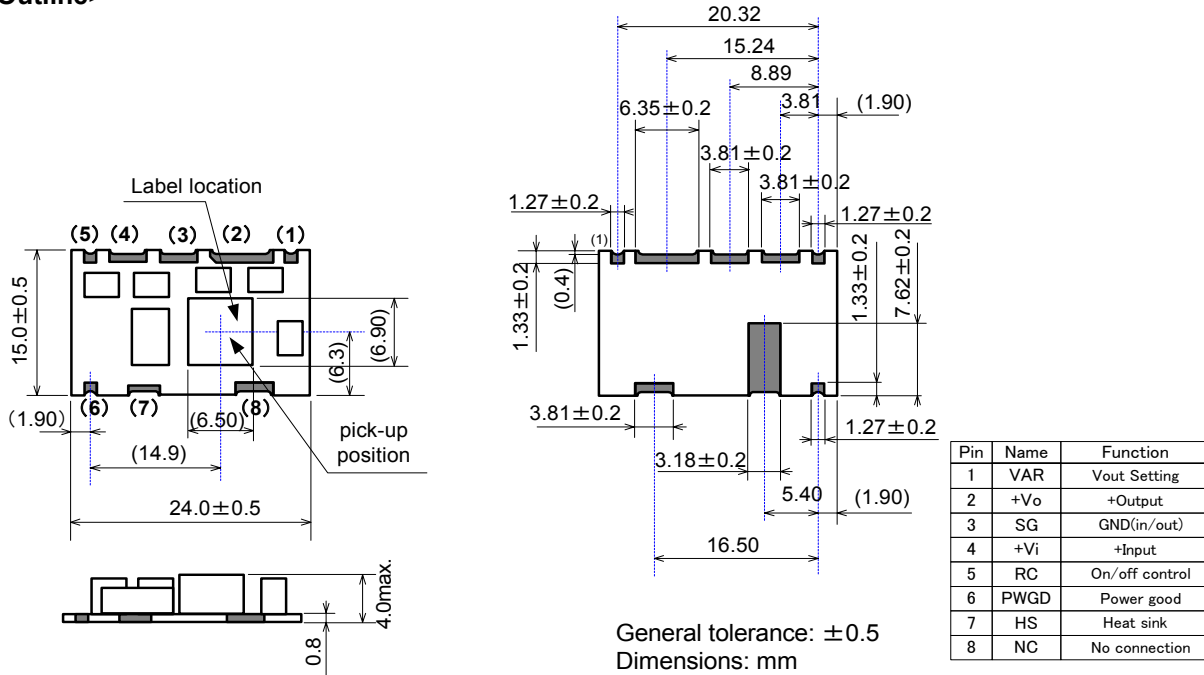
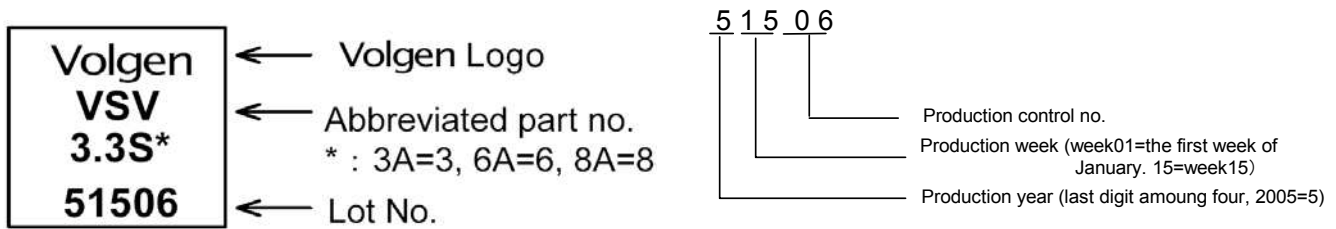

Figure 1

<Lot Number Display>



<Block Diagram>

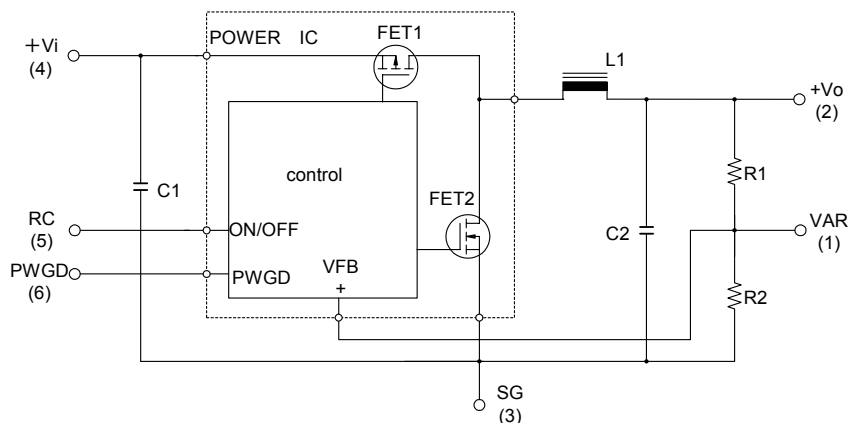

Figure 2