

PRODUCT SPECIFICATIONS

- PHYSICAL DATA
- EXTERNAL DIMENSIONS
- BLOCK DIAGRAM
- ABSOLUTE MAXIMUM RATINGS
- ELECTRICAL CHARACTERISTICS
- OPERATING PRINCIPLES & METHODS
- DISPLAY DATA RAM ADDRESS MAP
- ELECTRO-OPTICAL CHARACTERISTICS
- INTERFACE PIN CONNECTIONS
- CIRCUIT DIAGRAM
- RELIABILITY
- QUALITY GUARANTEE
- INSPECTION CRITERIA
- PRECAUTIONS FOR USING LCD MODULES
- USING LCD MODULES

■ PHYSICAL DATA

Item	Contents	Unit
LCD type	TN / STN / FSTN	---
LCD duty	1/16	---
LCD bias	1/5	---
Viewing direction	6 / 12	O'clock
Module size (W×H×T)	70 × 26.85 × 3.0MAX (2.76" × 1.06" × 0.11"MAX)	mm
Viewing area (W×H)	64 × 11.35 (2.51" × 0.45")	mm
Number of characters (characters×lines)	16 × 1	---
Character matrix (W×H)	5 × 8	Dots
Character size (W×H)	3.20 × 6.35 (0.126" × 0.250")	mm
Dot size (W×H)	0.60 × 0.75 (0.024" × 0.030")	mm
Dot pitch (W×H)	0.65 × 0.80 (0.026" × 0.032")	mm

■ EXTERNAL DIMENSIONS

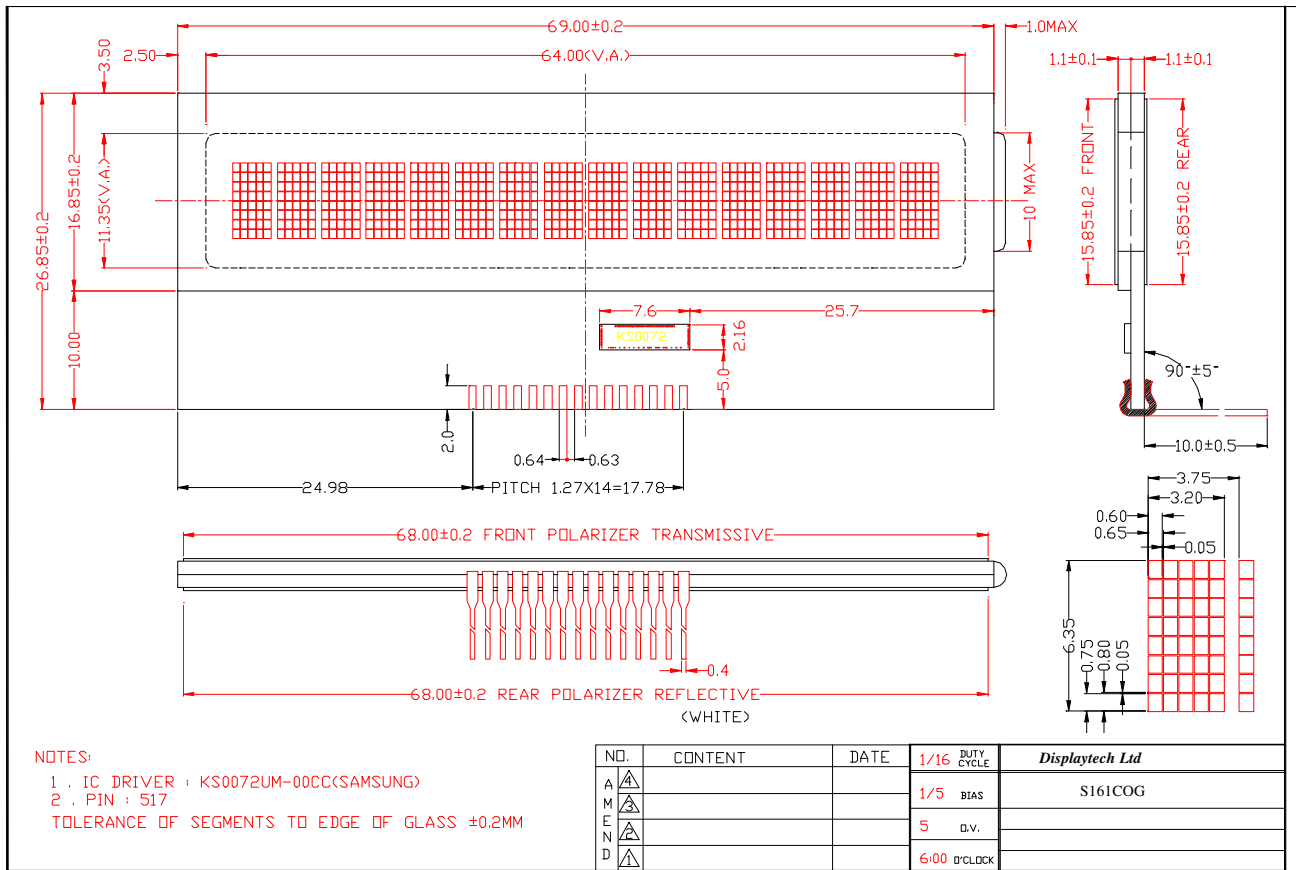

■ BLOCK DIAGRAM

15	14	13	12	11	10	9	8	7	6	5	4	3	2	1
DB7	DB6	DB5	DB4	DB3	DB2	DB1	DB0	E	R/W	RS	RESET	VO	VDD	VSS

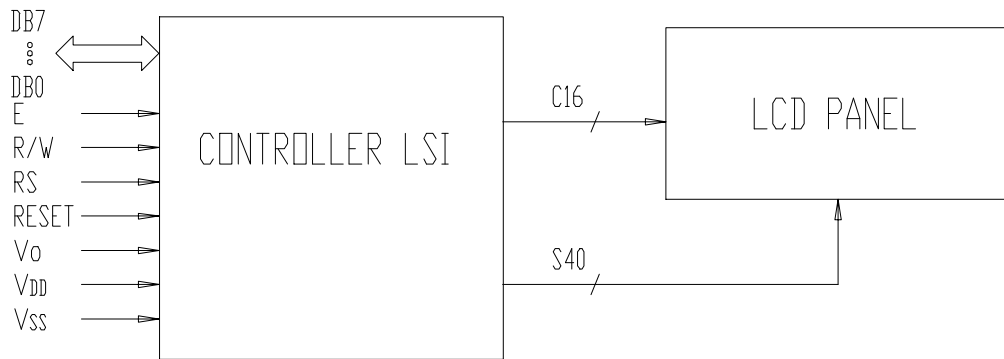

■ ABSOLUTE MAXIMUM RATINGS (Ta = 25j æ

Parameter	Symbol	Min	Max	Unit
Supply voltage for logic	VDD	-0.3	7.0	V
Supply voltage for LCD	VDD - VO	-0.3	+13V	V
Input voltage	VI	-0.3	VDD+0.3	V
Normal operating temperature	TOP	0	50	°C
Normal storage temperature	TST	-10	60	°C
Wide operating temperature	TOP	-20	70	°C
Wide storage temperature	TST	-30	80	°C

■ ELECTRICAL CHARACTERISTICS (VDD = +5V±10% , VSS = 0V, Ta = 25j æ

DC Characteristics

Parameter	Symbol	Condition	Min	Typ	Max	Unit
Supply voltage for logic	VDD	---	4.5	5.0	5.5	V
Supply current for logic	IDD	Internal oscillation Fosc=270KHZ	---	1.5	1.8	mA
Operating voltage for LCD	VDD - VO	0j æ	---	5.6	---	V
		25j æ	---	5.0	---	V
		50j æ	---	4.7	---	V
Input voltage (1) ' H ' level	VIH	All Input / Output except E Terminal	0.7VDD	---	VDD	V
Input voltage (1) ' L ' level	VIL		-0.3	---	0.8	V
Input voltage (2) ' H ' level	VIH	Only E Terminal	0.8VDD	---	VDD	V
Input voltage (2) ' L ' level	VIL		---	---	0.2VDD	V

AC Characteristics(VDD=4.5-5.5V,Ta=-30-+85j æ

● Write mode

Parameter	Symbol	Min	Max	Unit
Enable Cycle Time	tCYCE	500	---	Ns
Enable Pulse Width ' H ' Level	PWEH	230	---	ns
Enable Pulse Width ' L ' Level	PWEL	230	---	ns
Enable Rise Time	tEr	---	20	ns
Enable Fall Time	tEf	---	20	ns
Set Up Time for RS , R/W	tAS	40	---	ns
Address Hold Time	tAH	10	---	ns
Data Set Up Time	tDSW	80	---	ns
Data Hold Time	tH	10	---	ns

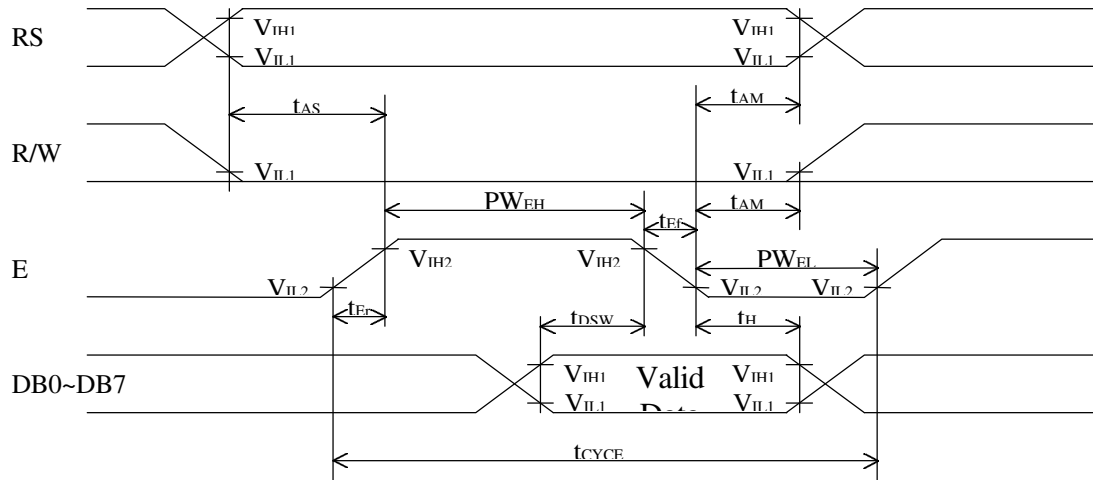

● Read Operation

Parameter	Symbol	Min	Max	Unit
Enable Cycle Time	t_{CYCE}	500	---	ns
Enable Pulse Width 'H' Level	PW_{EH}	230	---	ns
Enable Pulse Width 'L' Level	PW_{EL}	230	---	ns
Enable Rise Time	t_{Er}	---	20	ns
Enable Fall Time	t_{Ef}	---	20	ns
Set Up Time for RS , R/W	t_{AS}	40	---	ns
Address Hold Time	t_{AH}	10	---	ns
Data Delay Time	t_{DDR}	---	240	ns
Data Hold Time	t_{DHR}	20	---	ns

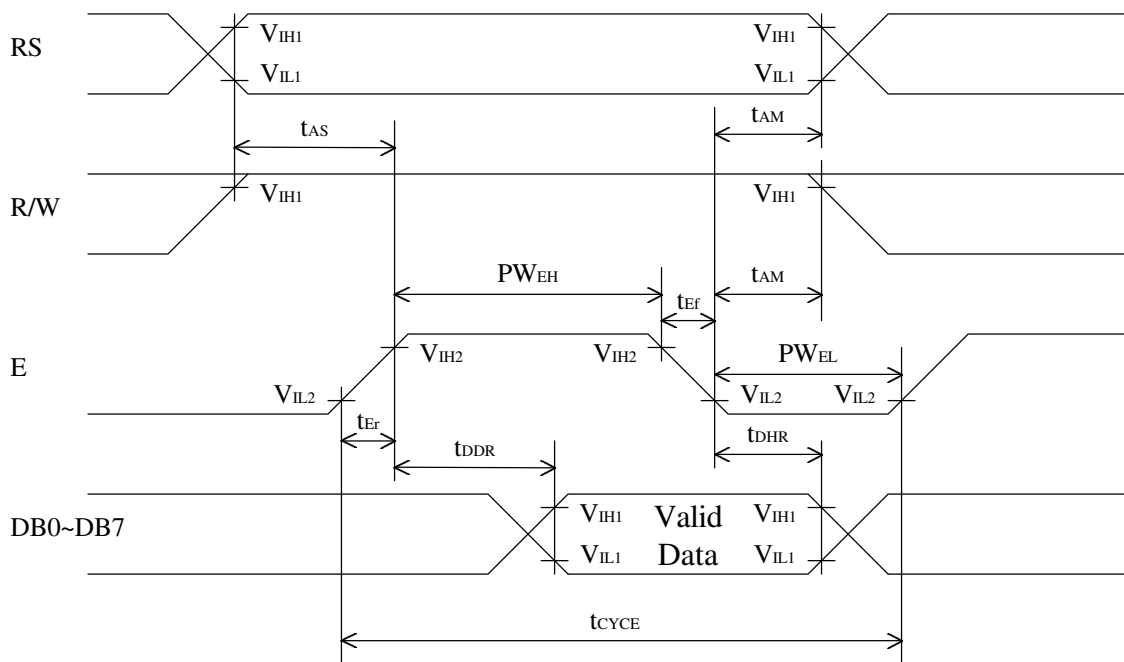

■ OPERATING PRINCIPLES & METHODS

Description For Each Blocks

● Register

The KS0072 incorporates two 8-bit registers, an Instruction Register (IR) and a Data Register (DR). The Register (IR) stores instruction codes such as “Clear Display” and “Return Home”, and address data for Display Data RAM (DD RAM) and Character Generator RAM (CG RAM). The MPU can write the instruction code and address data to the Register (IR), but it cannot read out from the Register (IR).

The Register (DR) is a temporary stored register, the data stored in the Register (DR) is written into the DD RAM or CG RAM and read out from the DD RAM or CG RAM. The data in the Register (DR) written by the MPU is transferred automatically to the DD RAM or CG RAM by internal operation.

When the address data for the DD RAM or CG RAM is written into the Register (IR), the addressed data in the DD RAM or CG RAM is transferred to the Register (DR). By the MPU read out the data in the Register (DR), the data transmitting process is performed completely. After reading the data in the Register (DR) by the MPU, the next address data in the DD RAM or CG RAM is transferred automatically to the Register (DR) to provide for the next MPU reading. These two registers are selected by the selection signal RS as shown below :

Table 1 shows register operation controlled by RS and R/W signals.

Table 1. Register Operation

RS	R/W	Selected Register	Operation
0	0	IR	Write
0	1		Read busy flag (DB7) and address counter (DB0~DB6)
1	0	DR	Write (DR to DD or CG RAM)
1	1		Read (DD or CG RAM to DR)

● Busy Flag

When the internal circuits are in the operation mode. the busy flag is “1”, and any instruction reading is inhibited. The busy flag (BF) is output at DB7 when RS = “0” and R/W = “1” as shown in table 1. The next instruction should be written after busy flag (BF) goes to “0”.

● Address Counter

The address Counter (AC) addressing the DD RAM and CG RAM. When the address setting instruction is written into the Register (IR), the address information is transferred from Register (IR) to counter (AC). The selection of either the DD RAM or CG RAM is also determined by this instruction. After writing (or reading) the display data to (or from) the DD RAM or CG RAM, the Counter (AC) increments (or decrements) The address data in the Counter (AC) is output from DB6 ~ DB0 when RS = “0” and R/W = “1” as shown in Table 1.

● Display Data RAM (DD RAM)

The display data RAM (DD RAM) consists of 16 x 8 bits, stores up to 16-character display data represented in 8-bit code. The DD RAM address data set in the Address Counter (AC) is represented in hexadecimal.

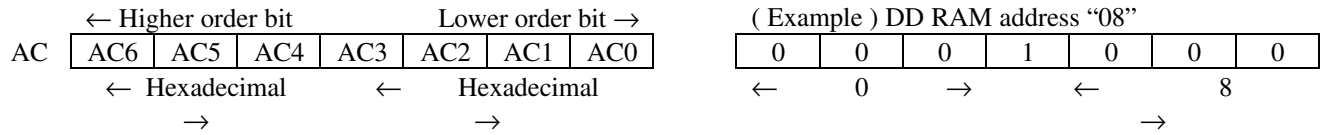

The KS0072 has two kinds of addressing mode called "addressing mode 1" and "addressing mode 2" which is determined by the Function Set Instruction (A = 0 or 1). "addressing mode 1" is using consecutive address of (00)H through (0F)H for front half 8-character and last half 8-character. "addressing mode 2" is not using consecutive address likes as (00)H through (07)H and (40)H through (47)H for front half 8-character and last half 8-character respectively.

(a) 16-character 1-line display

< Addressing mode 1 : A = 0, M1 = 0 > : The relation between DD RAM address and display position on the LCD is shown below.

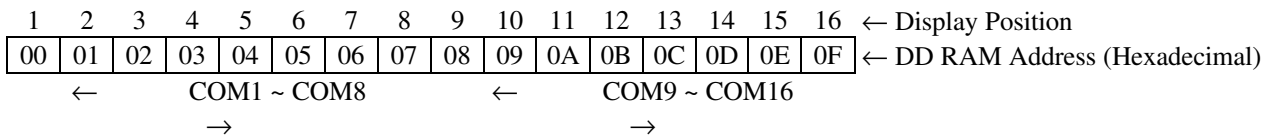

When the display shift is performed, the DD RAM address changes as follow :

(Left Shift Display)

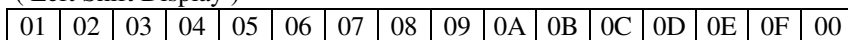

(Right Shift Display)

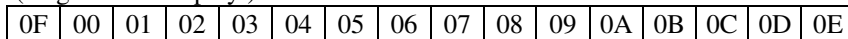

< Addressing mode 2 : A = 1, M1 = 0 > : The relation between DD RAM address and display position on the LCD is shown below.

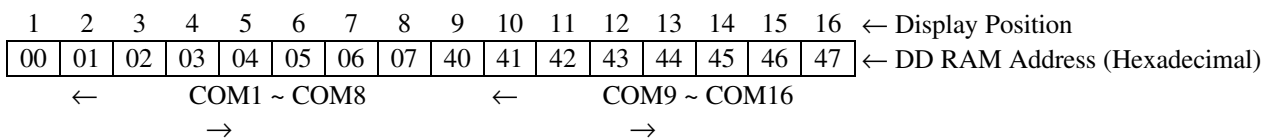

When the display shift is performed, the DD RAM address changes as follow :

(Left Shift Display)

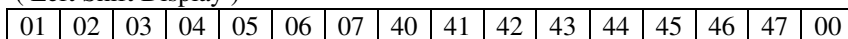

(Right Shift Display)

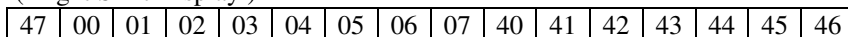

(b) 8-character 2-line display

It is not applicable in this product.

● Character Generator ROM (CG ROM)

The Character Generator ROM (CG ROM) generates 5 x 7 dots character pattern represented in 8-bit character codes. The storage capacity is up to 192 kinds of 5 x 7 dots character pattern. The correspondence between character code and standard character pattern of KS0072 is shown in Table 2.

User-defined character pattern (Custom Font) are also available by mask option and the available address for Custom Font is from (21)H to (7F)H and from (A0)H to (FF)H.

Table 2. CG ROM Character Pattern (ROM version-00)

Standard Character Pattern (NJU6460A)

upper 4 bit lower 4 bit	0000	0001	0010	0011	0100	0101	0110	0111	1000	1001	1010	1011	1100	1101	1110	1111
0000	CG RAM (1)															
0001	(2)															
0010	(3)															
0011	(4)															
0100	(1)															
0101	(2)															
0110	(3)															
0111	(4)															
1000	(1)															
1001	(2)															
1010	(3)															
1011	(4)															
1100	(1)															
1101	(2)															
1110	(3)															
1111	(4)															

● **Timing Generator**

The timing generator generates a timing signals for the DDRAM, CGRAM, CGROM. and other internal circuits operation. RAM read timing for the display and internal operation timing for MPU access are separately generated, so that they may not interfere with each other. Therefore. when the data write to the DD RAM for example, there will be no undesirable influence, such as flickering, in areas other than the display area.

● **LCD Driver**

LCD driver consist of 16-common driver and 40-segment driver. The 40 bits of character pattern data are shifted in the shift-register and latched when the 40 bits shift performed completely. This latched data controls display driver to output LCD driving waveform.

● **Cursor Blinking Control Circuit**

This circuit controls cursor On/Off and cursor position character blinks. The cursor or blinks appear in the digit residing at the DD RAM address set in the address counter (AC). When the address counter is (04)H, a cursor position is shown as follows:

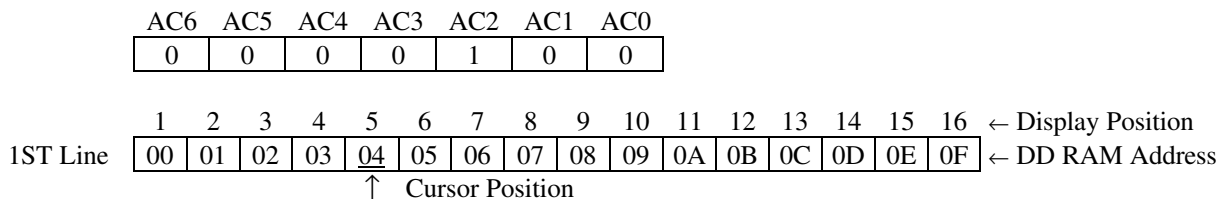

Note : The cursor or blinks appear when the address counter (AC) selects the CG RAM. But the displayed the cursor and blink are meaningless. If the AC storing the CG RAM address data, the cursor and blink are displayed in the meaningless position.

Interface With MPU

KS0072 can be interfaced with boyh of 4/8 bit MPU and the two-time 4-bit or one-time 8-bit data transfer is available.

● **4-bit MPU Interface**

When the interface length is 4-bit, the data transfer is performed by 4 lines connected to DB4 to DB7 (DB0 to DB3 are not used). The data transfer with the MPU is completed by the two-time 4-bit data transfer. The data transfer is executed in the sequence of upper 4-bit (the data DB4 to DB7 at 8-bit length) and lower 4-bit (the data DB0 to DB3 at 8-bit length). The busy flag check must be executed after two-time 4-bit data transfer (1 instruction execution). In this case the data of busy flag and address are also output twice.

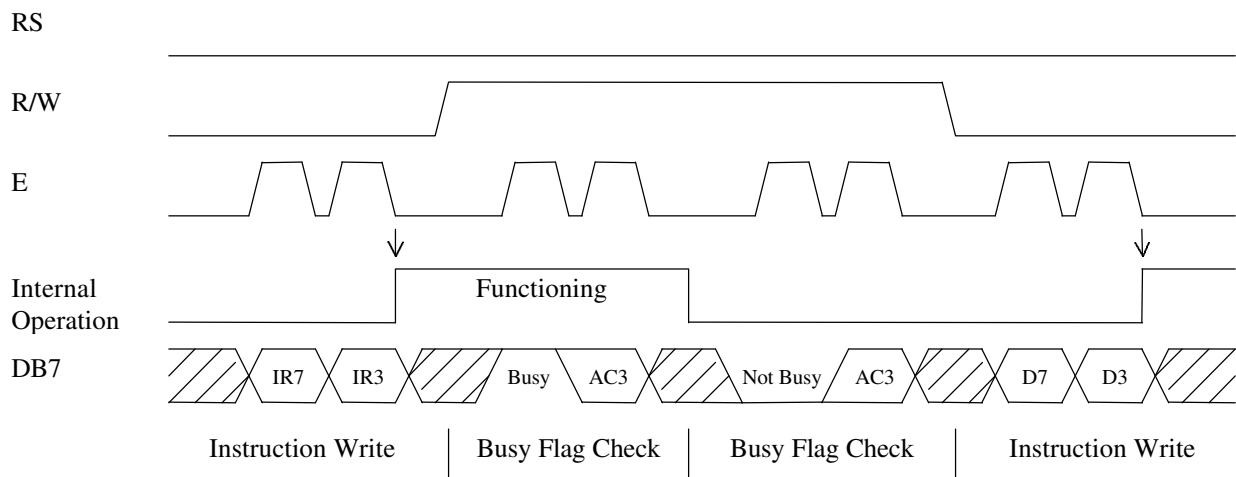

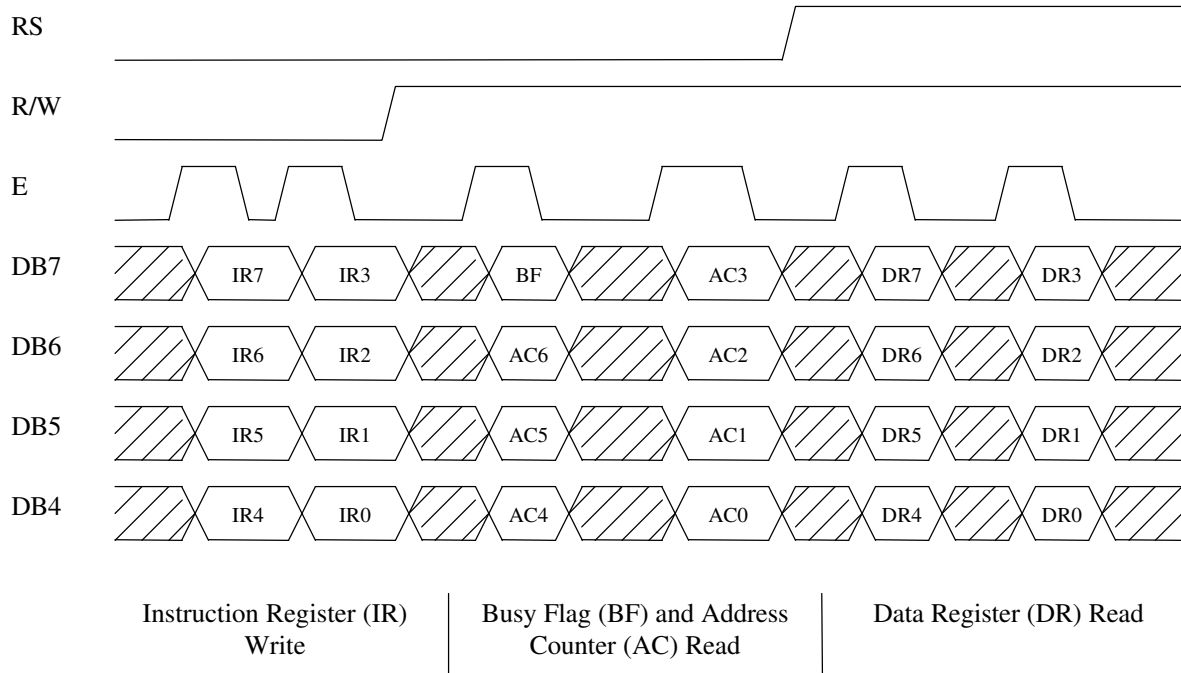

● 8-bit MPU Interface

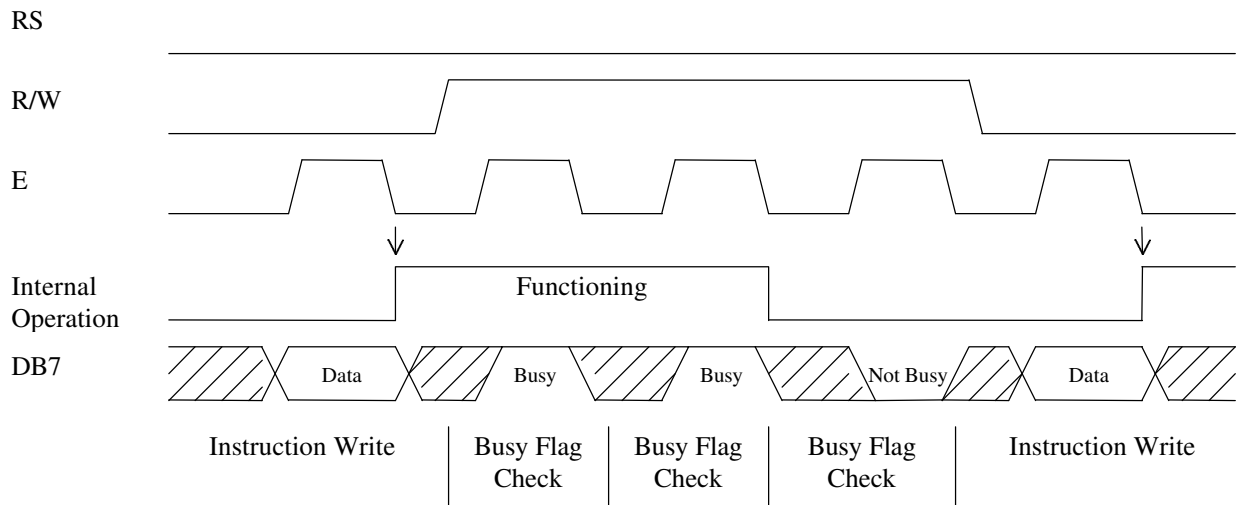

Instructions

The KS0072 incorporates two registers, an Instruction Register (IR) and a Data Register (DR). These two registers store control information temporarily to allow interface between KS0072 and MPU or peripheral ICs operating different cycles. The operation of KS0072 is determined by this control signal from MPU. The control information includes register selection signals (RS), read/write signals (R/W) and data bus signals (DB0 to DB7). Table 4 shows each instruction and its operating time.

Table 4. Table of Instructions

Instructions	Code										Description	Exec Time
	RS	R/W	DB 7	DB 6	DB 5	DB 4	DB 3	DB 2	DB 1	DB 0		
Maker Test	0	0	0	0	0	0	0	0	0	0	All "0" code is using for maker testing.	---
Clear Display	0	0	0	0	0	0	0	0	0	1	Display clear and sets DD RAM address 0 in AC.	1.52ms
Return Home	0	0	0	0	0	0	0	0	1	*	Sets DD RAM address 0 in AC and returns display being shifted to original position. DD RAM contents remain unchanged	37μs
Entry Mode Set	0	0	0	0	0	0	0	1	I/D	S	Sets cursor move direction and specifies shift of display are performed in data read/write. I/D=1 : Increment, I/D=0 : Decrement S=1 : Accompanies display shift S=0 : Not shift	37μs
Display On/Off Control	0	0	0	0	0	0	1	D	C	B	D=1 : Display On, D=0 : Display Off C=1 : Cursor On, C=0 : Cursor Off B=1 : Cursor position character blink B=0 : Not blink	37μs
Cursor or Display Shift	0	0	0	0	0	1	S/C	R/L	*	*	Moves cursor and shifts display without changing DD RAM contents S/C=1 : Display shift S/C=0 : Cursor shift R/L=1 : Shift to the right R/L=0 : Shift to the left	56μs
Function Set	0	0	0	0	1	DL	A	*	M1	M0	DL=1 : 8 bits, DL=0 : 4 bits A=0 : Addressing mode 1 A=1 : Addressing mode 2 M1=0 : 16-Character 1-Line M1=1 : 8-Character 2-Line M0=0 : Pin configuration mode A M0=1 : Pin configuration mode B	37μs
Set CG RAM Address	0	0	0	1	*	← ACG →					Sets CG RAM address. After this instruction, the data is transferred on CG RAM.	37μs
Set DD RAM Address	0	0	1	← ADD →							Sets DD RAM address. After this instruction, the data is transferred on DD RAM.	37μs
Read Busy Flag & Address	0	1	BF	← AC _{DD} →							Reads busy flag and AC contents.	0μs
	0	1	BF	*	*	← ACCG →					BF=1 : Internally operating BF=0 : Can accept instruction	
Write Data to CG & DD RAM	1	0	*	*	*	← Write Data (CG) →					Writes data into CG or DD RAMs.	37μs
	1	0	← Write Data (DD) →									
Read Data from CG & DD RAM	1	1	*	*	*	← Read Data (CG) →					Reads data from CG or DD RAMs	56μs
	1	1	← Read Data (DD) →									
Explanation of Abbreviation	DD RAM : Display data RAM, CG RAM : Character generator RAM ACG : CG RAM address, ADD : DD RAM address.(Corresponds to cursor address) AC : Address counter used for both of DD and CG RAMs											

* = Don't Care

Initialization

● Initialization By Internal Reset Circuits

The KS0072 is automatically initialized by internal power on initialization circuits when the power is turned on. In the internal power on initialization, following instructions are executed. During the Internal power on initialization, the busy flag (BF) is “1” and this status is kept 10 ms after V_{DD} rises to 4.5V.

Initialization flow is shown below :

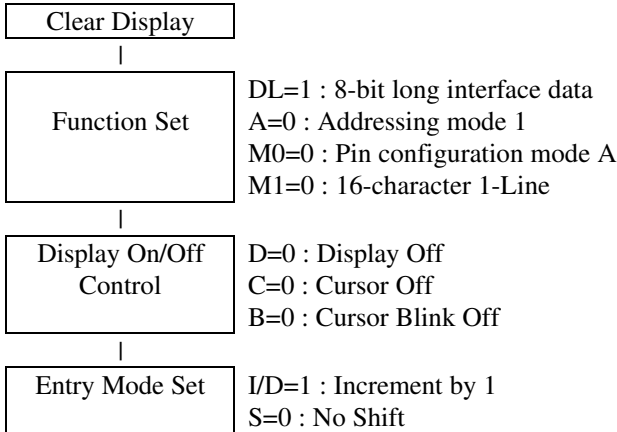

Note : If the condition of power supply rise time described in the Electrical Characteristics is not satisfied, the internal Power On Initialization Circuits will not operate and initialization will not be performed. In this case the initialization by MPU software is required.

● Initialization By Hardware

The KS0072 incorporates RESET terminal to initialize the all system. When the “L” level input over than 1.2ms to the RESET terminal, reset sequence is executed. In this time, busy signal output during 10ms after RESET terminal goes to “L”.

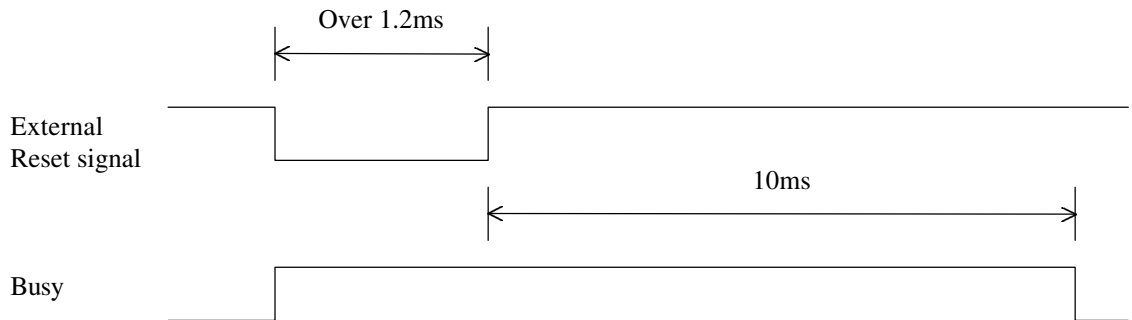

● Initialization By Instruction

If the power supply conditions for the correct operation of the internal reset circuits are not met, the KS0072 must be initialized by the instruction.

(a) Initialization by instruction in 8-bit interface

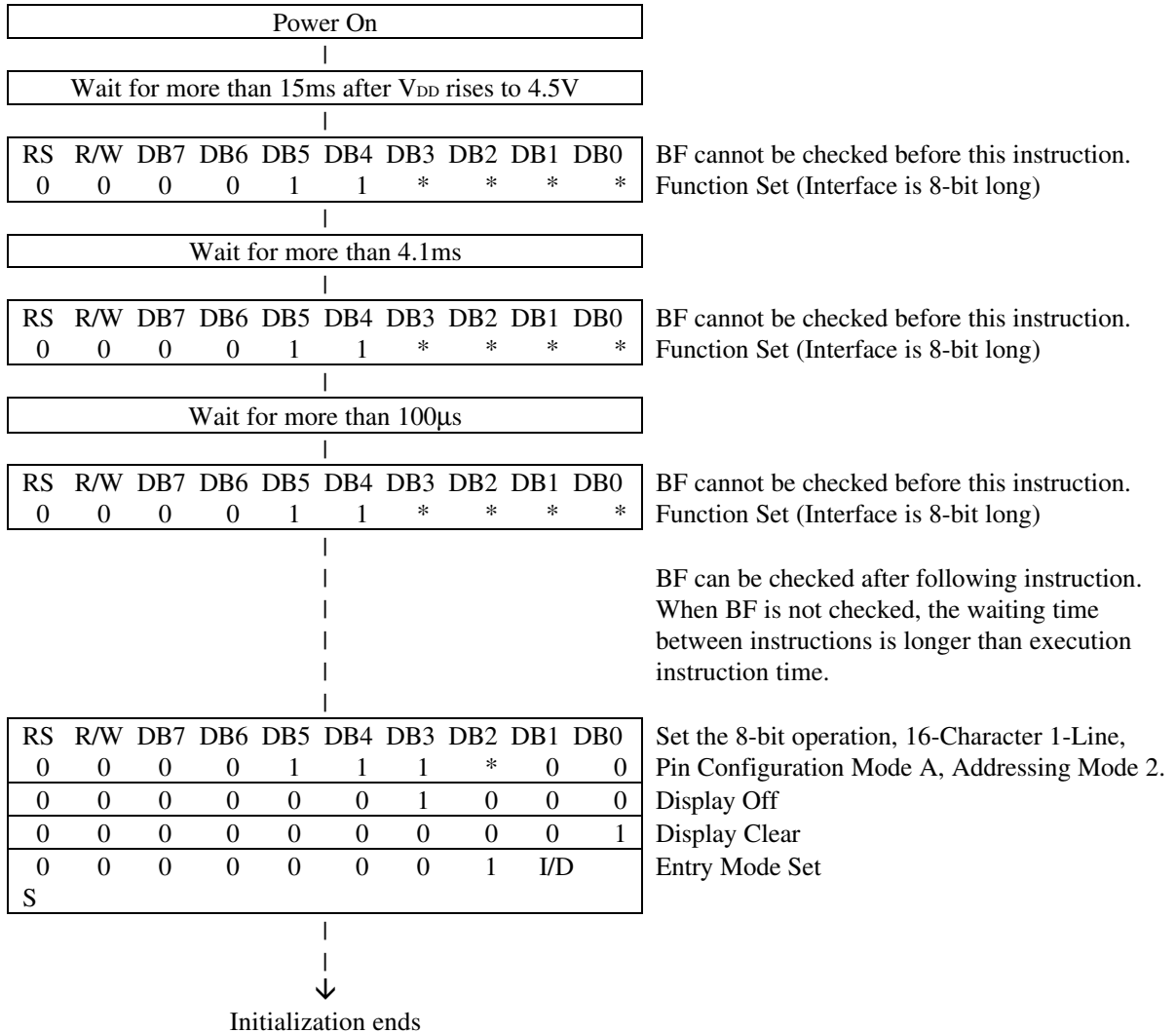

(b) Initialization by instruction in 4-bit interface

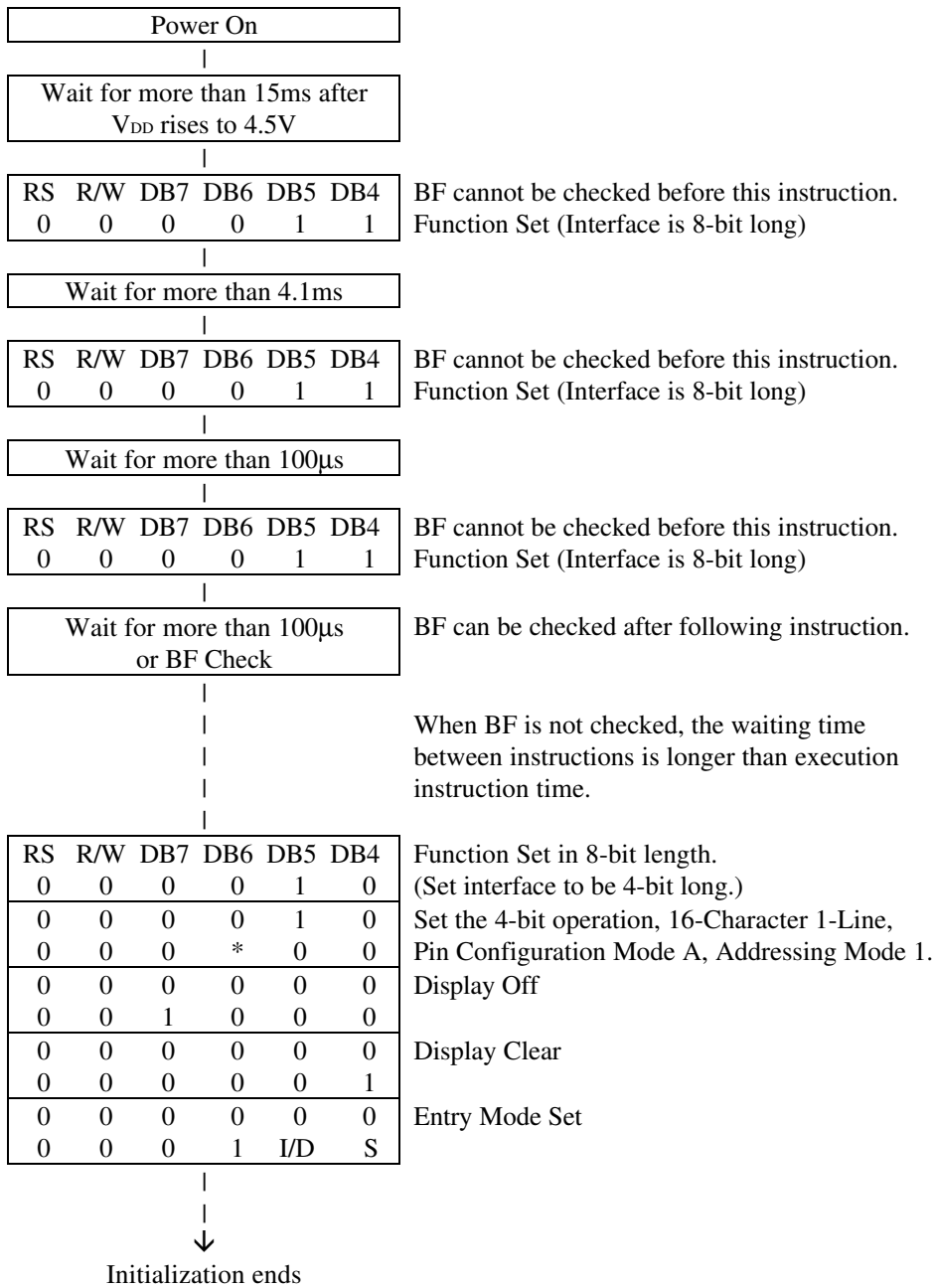

■ DISPLAY DATA RAM ADDRESS MAP

Characters	1	2	3	4	5	6	7	8	9	10	11	12	13	14	15	16
First line	00H	01H	02H	03H	04H	05H	06H	07H	40H	41H	42H	43H	44H	45H	46H	47H

■ ELECTRO-OPTICAL CHARACTERISTICS ($V_{OP} = 5.2V$, $T_a = 25^{\circ}C$)

Item	Symbol	Condition	Min	Typ	Max	Unit	Remarks	Note
Response time	Tr	---	---	164	---	ms	---	1
	Tf	---	---	68	---	ms	---	1
Contrast ratio	Cr	---	---	8.1	---	---	---	2
Viewing angle range	θ	$Cr \geq 2$	45	---	---	deg	$\varnothing = 90^{\circ}$	3
			40	---	---	deg	$\varnothing = 270^{\circ}$	3
			32	---	---	deg	$\varnothing = 0^{\circ}$	3
			12	---	---	deg	$\varnothing = 180^{\circ}$	3

Note1: Definition of response time.

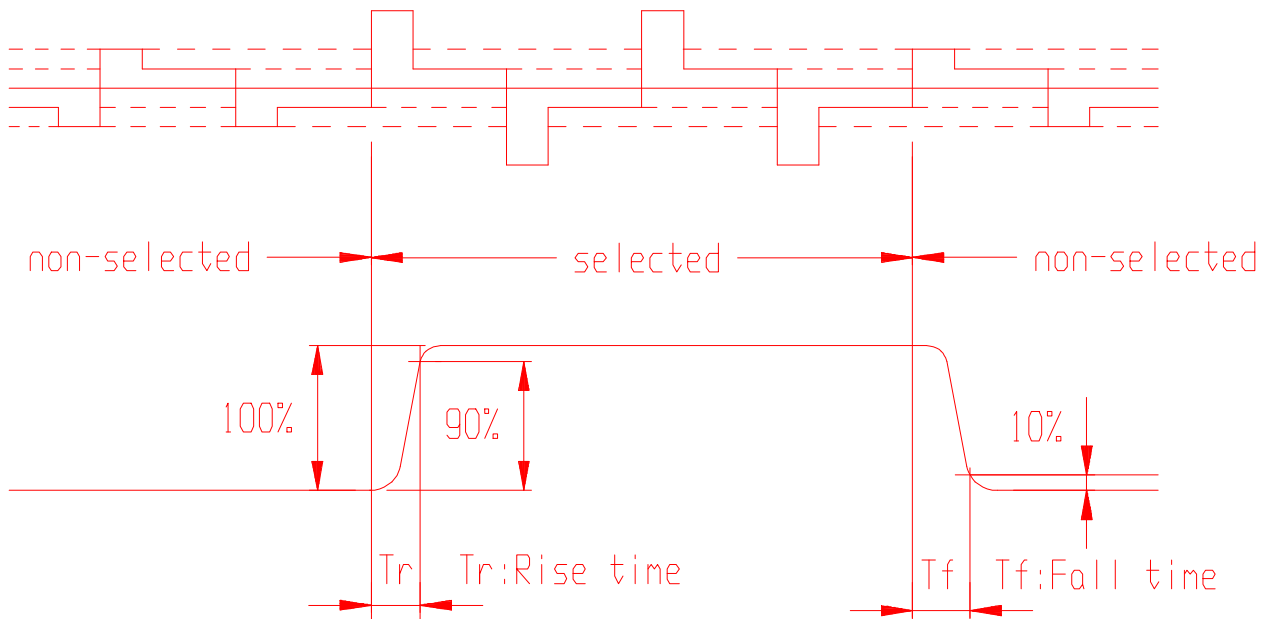

Note2: Definition of contrast ratio 'Cr' .

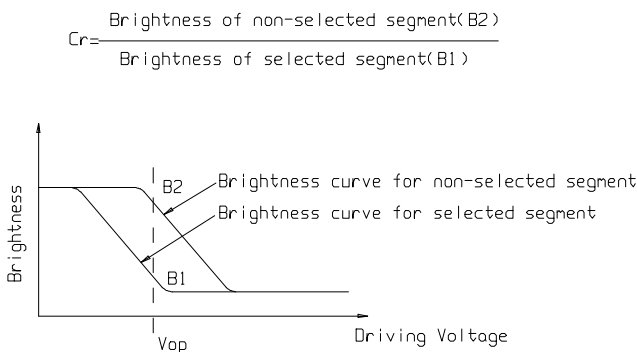

Note3: Definition of viewing angle range 'θ'.

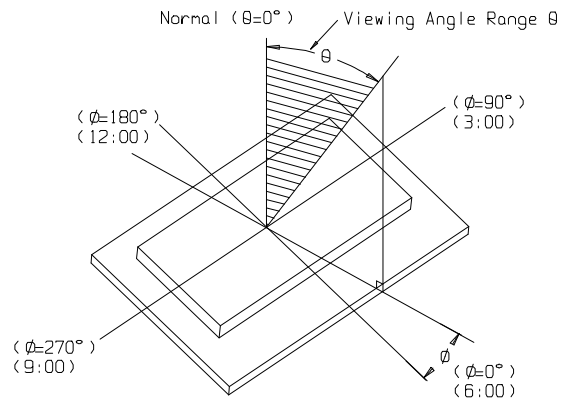

■ INTERFACE PIN CONNECTIONS

Pin NO.	Symbol	Level	Description
1	VSS	0V	Ground
2	VDD	5.0V	Supply voltage for logic
3	VO	---	Input voltage for LCD
4	RESET	L	Reset signal
5	RS	H/L	H : Data signal, L : Instruction signal
6	R/W	H/L	H : Read mode, L : Write mode
7	E	H, H → L	Chip enable signal
8	DB0	H/L	Data bit 0
9	DB1	H/L	Data bit 1
10	DB2	H/L	Data bit 2
11	DB3	H/L	Data bit 3
12	DB4	H/L	Data bit 4
13	DB5	H/L	Data bit 5
14	DB6	H/L	Data bit 6
15	DB7	H/L	Data bit 7

■ CIRCUIT DIAGRAM

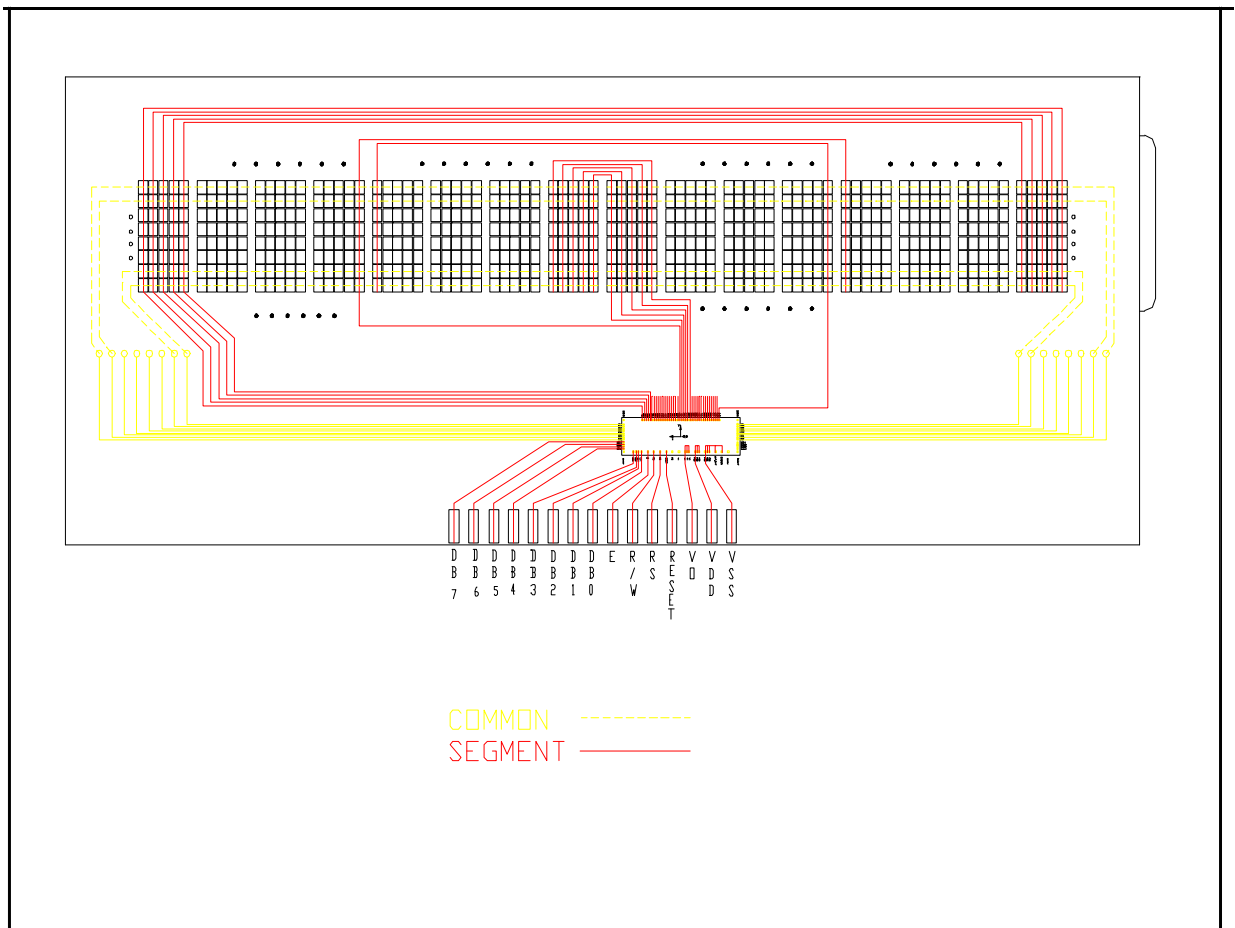

RELIABILITY

Content of Reliability Test

Environmental Test				
No.	Test Item	Content of Test	Test Condition	Applicable Standard
1	High temperature storage	Endurance test applying the high storage temperature for a long time.	60 °C 200 hrs	-----
2	Low temperature storage	Endurance test applying the low storage temperature for a long time.	-10 °C 200 hrs	-----
3	High temperature operation	Endurance test applying the electric stress (Voltage & Current) and the thermal stress to the element for a long time.	50 °C 200 hrs	-----
4	Low temperature operation	Endurance test applying the electric stress under low temperature for a long time.	0 °C 200 hrs	-----
5	High temperature / Humidity storage	Endurance test applying the high temperature and high humidity storage for a long time.	60 °C , 90 %RH 96 hrs	MIL-202E-103B JIS-C5023
6	High temperature / Humidity operation	Endurance test applying the electric stress (Voltage & Current) and temperature / humidity stress to the element for a long time.	40 °C , 90 %RH 96 hrs	MIL-202E-103B JIS-C5023
7	Temperature cycle	Endurance test applying the low and high temperature cycle. $ \begin{array}{c} -10^{\circ}\text{C} \quad \rightleftharpoons \quad 25^{\circ}\text{C} \quad \rightleftharpoons \quad 60^{\circ}\text{C} \\ 30\text{min} \quad \leftarrow \quad 5\text{min.} \quad \rightarrow \quad 30\text{min} \\ \leftarrow \quad \quad \quad \quad \quad \quad \quad \quad \quad \quad \rightarrow \\ \text{1 cycle} \end{array} $	-10°C / 60°C 10 cycles	-----
Mechanical Test				
8	Vibration test	Endurance test applying the vibration during transportation and using.	10~22Hz → 1.5mmp-p 22~500Hz → 1.5G Total 0.5hrs	MIL-202E-201A JIS-C5025 JIS-C7022-A-10
9	Shock test	Constructional and mechanical endurance test applying the shock during transportation.	50G half sign wave 11 msdc 3 times of each direction	MIL-202E-213B
10	Atmospheric pressure test	Endurance test applying the atmospheric pressure during transportation by air.	115 mbar 40 hrs	MIL-202E-105C
Others				
11	Static electricity test	Endurance test applying the electric stress to the terminal.	VS=800V , RS=1.5 kΩ CS=100 pF 1 time	MIL-883B-3015.1

*** Supply voltage for logic system = 5V. Supply voltage for LCD system = Operating voltage at 25°C.

Failure Judgement Criterion

Criterion Item	Test Item No.											Failure Judgment Criterion	
	1	2	3	4	5	6	7	8	9	10	11		
Basic specification													Out of the Basic Specification
Electrical characteristic													Out of the DC and AC Characteristic
Mechanical characteristic													Out of the Mechanical Specification Color change : Out of Limit Appearance Specification
Optical characteristic													Out of the Appearance Standard

■ QUALITY GUARANTEE

Acceptable Quality Level

Each lot should satisfy the quality level defined as follows.

- Inspection method : MIL-STD-105E LEVEL II Normal one time sampling
- AQL

Partition	AQL	Definition
A: Major	0.4%	Functional defective as product
B: Minor	1.5%	Satisfy all functions as product but not satisfy cosmetic standard

Definition of ‘LOT’

One lot means the delivery quantity to customer at one time.

Conditions of Cosmetic Inspection

- Environmental condition

The inspection should be performed at the 1m of height from the LCD module under 2 pieces of 40W white fluorescent lamps (Normal temperature 20~25°C and normal humidity 60±15%RH).

- Inspection method

The visual check should be performed vertically at more than 30cm distance from the LCD panel.

- Driving voltage

The V_o value which the most optimal contrast can be obtained near the specified V_o in the specification. (Within ±0.5V of the typical value at 25°C.).

■ INSPECTION CRITERIA

Module Cosmetic Criteria

No.	Item	Judgement Criterion	Partition
1	Difference in Spec.	None allowed	Major
2	Pattern peeling	No substrate pattern peeling and floating	Major
3	Soldering defects	No soldering missing No soldering bridge No cold soldering	Major Major Minor
4	Resist flaw on substrate	Invisible copper foil (Ø0.5mm or more) on substrate pattern	Minor
5	Accretion of metallic Foreign matter	No soldering dust No accretion of metallic foreign matters (Not exceed Ø0.2mm)	Minor Minor
6	Stain	No stain to spoil cosmetic badly	Minor
7	Plate discoloring	No plate fading, rusting and discoloring	Minor
8	Solder amount	a. Soldering side of PCB Solder to form a “ilet” all around the lead. Solder should not hide the lead form perfectly. (too much)	Minor
	1. Lead parts	b. Components side (In case of “through Hole PCB”) Solder to reach the Components side of PCB.	
	2. Flat packages	Either “oe” (A) or “eal” (B) of the lead to be covered by “ilet”. Lead form to be assume over solder.	Minor
	3. Chips	$(3/2) H \geq h \geq (1/2) H$	Minor

Screen Cosmetic Criteria (Non-Operating)

No.	Defect	Judgement Criterion	Partition										
1	Spots	In accordance with <i>Screen Cosmetic Criteria (Operating) No.1.</i>	Minor										
2	Lines	In accordance with <i>Screen Cosmetic Criteria (Operating) No.2.</i>	Minor										
3	Bubbles in polarizer	<table border="1"> <thead> <tr> <th>Size : d mm</th> <th>Acceptable Qty in active area</th> </tr> </thead> <tbody> <tr> <td>d ≤ 0.3</td> <td>Disregard</td> </tr> <tr> <td>0.3 < d ≤ 1.0</td> <td>3</td> </tr> <tr> <td>1.0 < d ≤ 1.5</td> <td>1</td> </tr> <tr> <td>1.5 < d</td> <td>0</td> </tr> </tbody> </table>	Size : d mm	Acceptable Qty in active area	d ≤ 0.3	Disregard	0.3 < d ≤ 1.0	3	1.0 < d ≤ 1.5	1	1.5 < d	0	Minor
Size : d mm	Acceptable Qty in active area												
d ≤ 0.3	Disregard												
0.3 < d ≤ 1.0	3												
1.0 < d ≤ 1.5	1												
1.5 < d	0												
4	Scratch	In accordance with spots and lines operating cosmetic criteria. When the light reflects on the panel surface, the scratches are not to be remarkable.	Minor										
5	Allowable density	Above defects should be separated more than 30mm each other.	Minor										
6	Coloration	Not to be noticeable coloration in the viewing area of the LCD panels. Back-lit type should be judged with back-lit on state only.	Minor										
7	Contamination	Not to be noticeable.	Minor										

Screen Cosmetic Criteria (Operating)

No.	Defect	Judgement Criterion	Partition																				
1	Spots	<p>A) Clear</p> <table border="1"> <thead> <tr> <th>Size : d mm</th> <th>Acceptable Qty in active area</th> </tr> </thead> <tbody> <tr> <td>d ≤ 0.1</td> <td>Disregard</td> </tr> <tr> <td>0.1 < d ≤ 0.2</td> <td>6</td> </tr> <tr> <td>0.2 < d ≤ 0.3</td> <td>2</td> </tr> <tr> <td>0.3 < d</td> <td>0</td> </tr> </tbody> </table> <p>Note : Including pin holes and defective dots which must be within one pixel size.</p> <p>B) Unclear</p> <table border="1"> <thead> <tr> <th>Size : d mm</th> <th>Acceptable Qty in active area</th> </tr> </thead> <tbody> <tr> <td>d ≤ 0.2</td> <td>Disregard</td> </tr> <tr> <td>0.2 < d ≤ 0.5</td> <td>6</td> </tr> <tr> <td>0.5 < d ≤ 0.7</td> <td>2</td> </tr> <tr> <td>0.7 < d</td> <td>0</td> </tr> </tbody> </table>	Size : d mm	Acceptable Qty in active area	d ≤ 0.1	Disregard	0.1 < d ≤ 0.2	6	0.2 < d ≤ 0.3	2	0.3 < d	0	Size : d mm	Acceptable Qty in active area	d ≤ 0.2	Disregard	0.2 < d ≤ 0.5	6	0.5 < d ≤ 0.7	2	0.7 < d	0	Minor
Size : d mm	Acceptable Qty in active area																						
d ≤ 0.1	Disregard																						
0.1 < d ≤ 0.2	6																						
0.2 < d ≤ 0.3	2																						
0.3 < d	0																						
Size : d mm	Acceptable Qty in active area																						
d ≤ 0.2	Disregard																						
0.2 < d ≤ 0.5	6																						
0.5 < d ≤ 0.7	2																						
0.7 < d	0																						
2	Lines	<p>A) Clear</p> <p>Note : () - Acceptable Qty in active area L - Length (mm) W - Width (mm) ∞ - Disregard</p> <p>B) Unclear</p>	Minor																				

“Clear” = The shade and size are not changed by Vo.

Screen Cosmetic Criteria (Operating) (Continued)

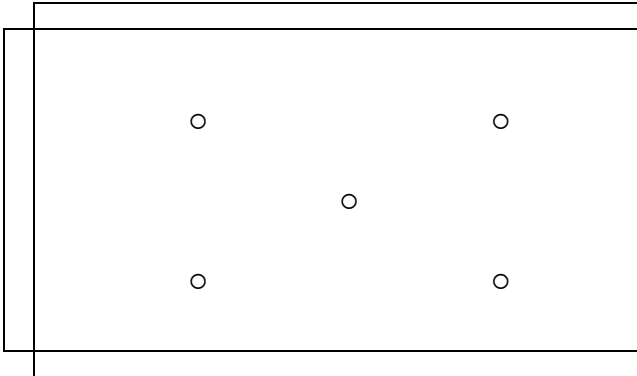
No.	Defect	Judgement Criterion	Partition
3	Rubbing line	Not to be noticeable.	
4	Allowable density	Above defects should be separated more than 10mm each other.	Minor
5	Rainbow	Not to be noticeable.	Minor
6	Dot size	To be 95% ~ 105% of the dot size (Typ.) in drawing. Partial defects of each dot (ex. pin-hole) should be treated as 'spot'. (see <i>Screen Cosmetic Criteria (Operating) No.1</i>)	Minor
7	Uneven brightness (only back-lit type module)	Uneven brightness must be $B_{MAX} / B_{MIN} \leq 2$ - B_{MAX} : Max. value by measure in 5 points - B_{MIN} : Min. value by measure in 5 points Divide active area into 4 vertically and horizontally. Measure 5 points shown in the following figure.  ○ : Measuring points	Minor

Note :

- (1) Size : $d = (\text{long length} + \text{short length}) / 2$
- (2) The limit samples for each item have priority.
- (3) Complexed defects are defined item by item, but if the number of defects are defined in above table, the total number should not exceed 10.
- (4) In case of "concentration", even the spots or the lines of "isregarded" size should not allowed. Following three situations should be treated as "concentration".
 - 7 or over defects in circle of $\varnothing 5\text{mm}$.
 - 10 or over defects in circle of $\varnothing 10\text{mm}$.
 - 20 or over defects in circle of $\varnothing 20\text{mm}$.

■ PRECAUTIONS FOR USING LCD MODULES

Handing Precautions

- (1) The display panel is made of glass. Do not subject it to a mechanical shock by dropping it or impact.
- (2) If the display panel is damaged and the liquid crystal substance leaks out, be sure not to get any in your mouth. If the substance contacts your skin or clothes, wash it off using soap and water.
- (3) Do not apply excessive force to the display surface or the adjoining areas since this may cause the color tone to vary.
- (4) The polarizer covering the display surface of the LCD module is soft and easily scratched. Handle this polarizer carefully.
- (5) If the display surface becomes contaminated, breathe on the surface and gently wipe it with a soft dry cloth. If it is heavily contaminated, moisten cloth with one of the following solvents :
 - Isopropyl alcohol
 - Ethyl alcohol
- (6) Solvents other than those above-mentioned may damage the polarizer. Especially, do not use the following.
 - Water
 - Ketone
 - Aromatic solvents
- (7) Exercise care to minimize corrosion of the electrode. Corrosion of the electrodes is accelerated by water droplets, moisture condensation or a current flow in a high-humidity environment.

(8) Install the LCD Module by using the mounting holes. When mounting the LCD module make sure it is free of twisting, warping and distortion. In particular, do not forcibly pull or bend the I/O cable or the backlight cable.

(9) Do not attempt to disassemble or process the LCD module.

(10) NC terminal should be open. Do not connect anything.

(11) If the logic circuit power is off, do not apply the input signals.

(12) To prevent destruction of the elements by static electricity, be careful to maintain an optimum work environment.

- Be sure to ground the body when handling the LCD modules.

- Tools required for assembling, such as soldering irons, must be properly grounded.

- To reduce the amount of static electricity generated, do not conduct assembling and other work under dry conditions.

- The LCD module is coated with a film to protect the display surface. Exercise care when peeling off this protective film since static electricity may be generated.

Storage Precautions

When storing the LCD modules, avoid exposure to direct sunlight or to the light of fluorescent lamps. Keep the modules in bags (avoid high temperature / high humidity and low temperatures below 0°C). Whenever possible, the LCD modules should be stored in the same conditions in which they were shipped from our company.

Others

Liquid crystals solidify under low temperature (below the storage temperature range) leading to defective orientation or the generation of air bubbles (black or white). Air bubbles may also be generated if the module is subject to a low temperature.

If the LCD modules have been operating for a long time showing the same display patterns, the display patterns may remain on the screen as ghost images and a slight contrast irregularity may also appear. A normal operating status can be regained by suspending use for some time. It should be noted that this phenomenon does not adversely affect performance reliability.

To minimize the performance degradation of the LCD modules resulting from destruction caused by static electricity etc., exercise care to avoid holding the following sections when handling the modules.

- Exposed area of the printed circuit board.

- Terminal electrode sections.

■ USING LCD MODULES

Liquid Crystal Display Modules

LCD is composed of glass and polarizer. Pay attention to the following items when handling.

(1) Please keep the temperature within specified range for use and storage. Polarization degradation, bubble generation or polarizer peel-off may occur with high temperature and high humidity.

(2) Do not touch, push or rub the exposed polarizers with anything harder than an HB pencil lead (glass, tweezers, etc.).

(3) N-hexane is recommended for cleaning the adhesives used to attach front/rear polarizers and reflectors made of organic substances which will be damaged by chemicals such as acetone, toluene, ethanol and isopropylalcohol.

(4) When the display surface becomes dusty, wipe gently with absorbent cotton or other soft material like chamois soaked in petroleum benzin. Do not scrub hard to avoid damaging the display surface.

(5) Wipe off saliva or water drops immediately, contact with water over a long period of time may cause deformation or color fading.

(6) Avoid contacting oil and fats.

(7) Condensation on the surface and contact with terminals due to cold will damage, stain or dirty the polarizers. After products are tested at low temperature they must be warmed up in a container before coming in contact with room temperature air.

(8) Do not put or attach anything on the display area to avoid leaving marks on.

(9) Do not touch the display with bare hands. This will stain the display area and degradate insulation between terminals (some cosmetics are determined to the polarizers).

(10) As glass is fragile. It tends to become or chipped during handling especially on the edges. Please avoid dropping or jarring.

Installing LCD Modules

The hole in the printed circuit board is used to fix LCM as shown in the picture below. Attend to the following items when installing the LCM.

- (1) Cover the surface with a transparent protective plate to protect the polarizer and LC cell.

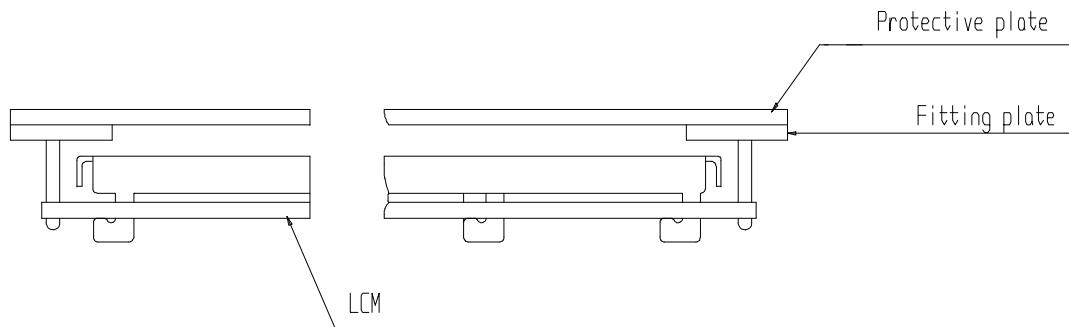

- (2) When assembling the LCM into other equipment, the spacer to the bit between the LCM and the fitting plate should have enough height to avoid causing stress to the module surface, refer to the individual specifications for measurements. The measurement tolerance should be $\pm 0.1\text{mm}$.

Precaution for Handling LCD Modules

Since LCM has been assembled and adjusted with a high degree of precision, avoid applying excessive shocks to the module or making any alterations or modifications to it.

- (1) Do not alter, modify or change the the shape of the tab on the metal frame.
- (2) Do not make extra holes on the printed circuit board, modify its shape or change the positions of components to be attached.
- (3) Do not damage or modify the pattern writing on the printed circuit board.
- (4) Absolutely do not modify the zebra rubber strip (conductive rubber) or heat seal connector.
- (5) Except for soldering the interface, do not make any alterations or modifications with a soldering iron.
- (6) Do not drop, bend or twist LCM.

Electro-Static Discharge Control

Since this module uses a CMOS LSI, the same careful attention should be paid to electrostatic discharge as for an ordinary CMOS IC.

- (1) Make certain that you are grounded when handling LCM.
- (2) Before remove LCM from its packing case or incorporating it into a set, be sure the module and your body have the same electric potential.
- (3) When soldering the terminal of LCM, make certain the AC power source for the soldering iron does not leak.
- (4) When using an electric screwdriver to attach LCM, the screwdriver should be of ground potential to minimize as much as possible any transmission of electromagnetic waves produced sparks coming from the commutator of the motor.
- (5) As far as possible make the electric potential of your work clothes and that of the work bench the ground potential.
- (6) To reduce the generation of static electricity be careful that the air in the work is not too dried. A relative humidity of 50%-60% is recommended.

Precaution for soldering to the LCM

- (1) Observe the following when soldering lead wire, connector cable and etc. to the LCM.

- Soldering iron temperature : $280^{\circ}\text{C} \pm 10^{\circ}\text{C}$.
- Soldering time : 3-4 sec.
- Solder : eutectic solder.

If soldering flux is used, be sure to remove any remaining flux after finishing to soldering operation. (This does not apply in the case of a non-halogen type of flux.) It is recommended that you protect the LCD surface with a cover during soldering to prevent any damage dur to flux spatters.

- (2) When soldering the electroluminescent panel and PC board, the panel and board should not be detached more than three times. This maximum number is determined by the temperature and time conditions mentioned above, though there may be some variance depending on the temperature of the soldering iron.

- (3) When remove the electoluminescent panel from the PC board, be sure the solder has completely melted, the soldered pad on the PC board could be damaged.

Precautions for Operation

- (1) Viewing angle varies with the change of liquid crystal driving voltage (V_0). Adjust V_0 to show the best contrast.
- (2) Driving the LCD in the voltage above the limit shortens its life.
- (3) Response time is greatly delayed at temperature below the operating temperature range. However, this does not mean the LCD will be out of the order. It will recover when it returns to the specified temperature range.
- (4) If the display area is pushed hard during operation, the display will become abnormal. However, it will return to normal if it is turned off and then back on.
- (5) Condensation on terminals can cause an electrochemical reaction disrupting the terminal circuit. Therefore, it must be used under the relative condition of 40°C , 50% RH.
- (6) When turning the power on, input each signal after the positive/negative voltage becomes stable.

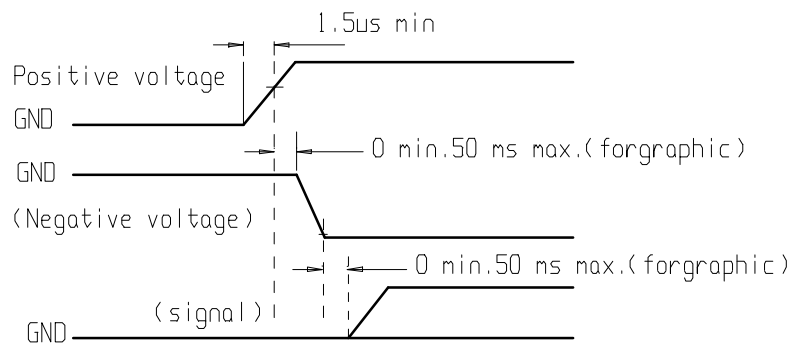

Storage

When storing LCDs as spares for some years, the following precaution are necessary.

- (1) Store them in a sealed polyethylene bag. If properly sealed, there is no need for dessicant.
- (2) Store them in a dark place. Do not expose to sunlight or fluorescent light, keep the temperature between 0°C and 35°C .
- (3) The polarizer surface should not come in contact with any other objects. (We advise you to store them in the container in which they were shipped.)
- (4) Environmental conditions :
 - Do not leave them for more than 168hrs. at 60°C .
 - Should not be left for more than 48hrs. at -20°C .

Safety

- (1) It is recommended to crush damaged or unnecessary LCDs into pieces and wash them off with solvents such as acetone and ethanol, which should later be burned.
- (2) If any liquid leaks out of a damaged glass cell and comes in contact with the hands, wash off thoroughly with soap and water.

Limited Warranty

Unless agreed between DISPLAYTECH and customer, DISPLAYTECH will replace or repair any of its LCD modules which are found to be functionally defective when inspected in accordance with DISPLAYTECH LCD acceptance standards (copies available upon request) for a period of one year from date of shipments. Cosmetic/visual defects must be returned to DISPLAYTECH within 90 days of shipment. Confirmation of such date shall be based on freight documents. The warranty liability of DISPLAYTECH limited to repair and/or replacement on the terms set forth above. DISPLAYTECH will not be responsible for any subsequent or consequential events.

Return LCM under warranty

No warranty can be granted if the precautions stated above have been disregarded. The typical examples of violations are :

- Broken LCD glass.
- PCB eyelet damaged or modified.
- PCB conductors damaged.
- Circuit modified in any way, including addition of components.
- PCB tampered with by grinding, engraving or painting varnish.
- soldering to or modifying the bezel in any manner.

Module repairs will be invoiced to the customer upon mutual agreement. Modules must be returned with sufficient description of the failures or defects. Any connectors or cable installed by the customer must be removed completely without damaging the PCB eyelet, conductors and terminals.