

---

## ARC-MC

---

### Data warehousing board for drivers, measuring and monitoring board for power systems

- DIN41651 connector technology
- Input: 1 x 26-pin connector
- Output: 3 x 14-pin connectors or 1 x 26-pin connector
- 40W power supply
- Input voltage : 15V to 36V –  
Output voltage : 15V regulated
- Full compatibility with ARCAL-2106, ARCAL-2315, ARCAL-E+3P and ARCAL-E+ boards
- Measure of 1 to 3 currents, of 1 voltage and of 1 to 4 temperatures
- Default for temperature overshoot

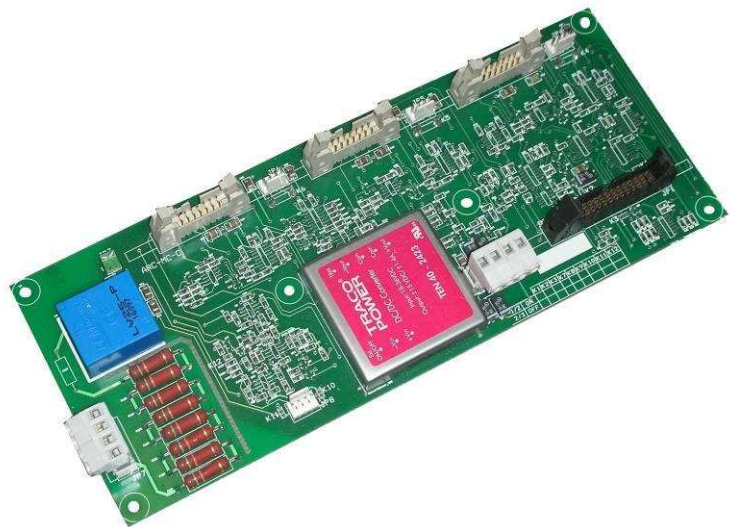

All information included in this document is Arcel's or its respective authors' property. Therefore, any reproduction, use, adaptation, modification, integration, translation, commercial use, in whole or in part, by any means or any form (electronic, written or verbal) is forbidden, without prior written permission of Arcel or its respective authors.



The ARC-MC board is an interface for IGBT or MOSFET drivers which despatches the power supply, control and error signals on 3 independent channels or on a connector which groups all the orders. In addition to that the ARC-MC board offers a 24V /  $\pm 15V$  – 1.5A adaptation.

The ARC-MC is also a measuring and monitoring board for power systems. It is able to measure up to 7 parameters simultaneously and to release a default in case of unusual operating of the application. The measured values are following:

- ✓ 1 to 3 temperatures (with the ARCAL-E+3P)
- ✓ 1 to 3 currents (alternating or direct)
- ✓ 1 DC bus voltage

Each default threshold can be inhibited and offers a hysteresis for a better immunity against disturbances. The specifications and the architecture of the ARC-MC make it easy for use in very different applications.

All information included in this document is Arcel's or its respective authors' property. Therefore, any reproduction, use, adaptation, modification, integration, translation, commercial use, in whole or in part, by any means or any form (electronic, written or verbal) is forbidden, without prior written permission of Arcel or its respective authors.



1. Schematic Diagram.....	5
2. Description.....	6
3. Maximum Electrical Specifications .....	7
4. Functional Description and Electrical Specifications.....	7
4.1. Power supply .....	7
4.2. Electrical Specifications .....	8
4.3. Voltage measurement.....	8
4.3.1. Description of voltage measure.....	8
4.3.2. Application of the voltage measure .....	8
4.3.3. Electrical specifications.....	9
4.3.4. Electrical specifications.....	9
4.4. Temperature Measurement.....	9
4.4.1. Description and transfer function .....	9
4.4.2. Temperature monitoring.....	10
4.4.3. Electrical specifications.....	10
4.5. Measure of current.....	11
4.5.1. Description and transfer function .....	11
4.5.2. Determination of measure resistance for Hall sensors .....	11
4.5.3. Determination of measure resistance for open loop sensors.....	12
4.5.4. Electrical specifications.....	12
4.6. Pin connection of the connectors .....	13
4.6.1. JP1 connectors (control and power supply connectors, connectors for the measure and error signals) .....	13
4.6.2. Auxiliary power supply connectors (JP2).....	14
4.6.3. X1, X2, X3 connectors (14-pin driver connectors) .....	14
4.6.4. JP3 connector (voltage sensor) .....	14

All information included in this document is Arcel's or its respective authors' property. Therefore, any reproduction, use, adaptation, modification, integration, translation, commercial use, in whole or in part, by any means or any form (electronic, written or verbal) is forbidden, without prior written permission of Arcel or its respective authors.



4.6.5.	JP8 connector (Information about the measure of auxiliary voltage) .....	15
4.6.6.	JP3 connector (NTC connector).....	15
4.6.7.	JP4, JP5, JP6 connectors (current sensors) .....	15
4.7.	Summary table of configurations.....	16
4.8.	Mechanical data and connector tracking, configuration strapps .....	17

All information included in this document is Arcel's or its respective authors' property. Therefore, any reproduction, use, adaptation, modification, integration, translation, commercial use, in whole or in part, by any means or any form (electronic, written or verbal) is forbidden, without prior written permission of Arcel or its respective authors.



1. SCHEMATIC DIAGRAM

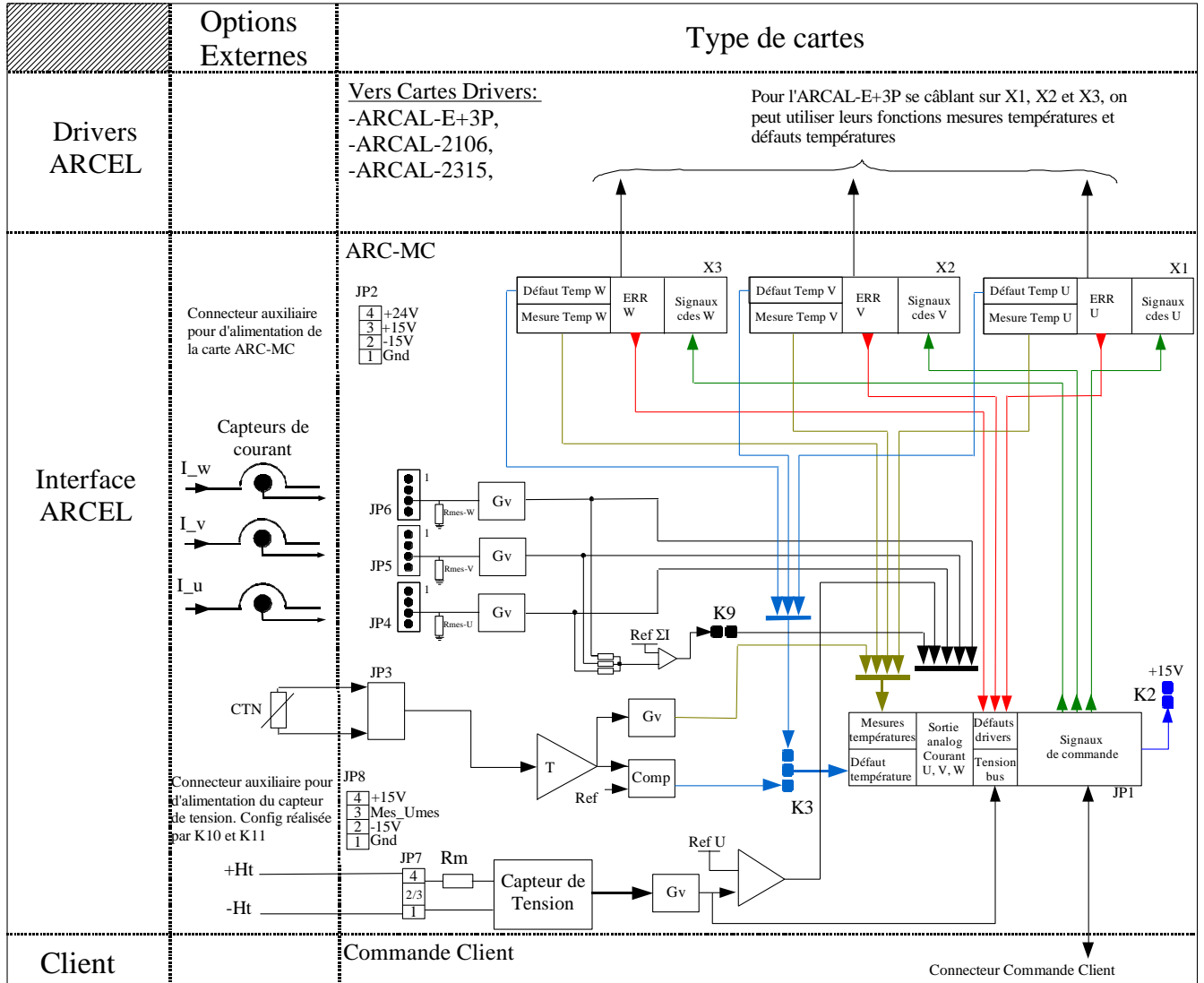

Outline 1: Architecture of the ARC-MC

All information included in this document is Arcel's or its respective authors' property. Therefore, any reproduction, use, adaptation, modification, integration, translation, commercial use, in whole or in part, by any means or any form (electronic, written or verbal) is forbidden, without prior written permission of Arcel or its respective authors.



## 2. DESCRIPTION

The ARC-MC enables to measure 5 important values in power converters. The different parameters are checked and permanently compared to the limit values of the so called « security » operating areas. In case of exceeding values, the default signal will be activated. The default signal is of type “open collector”.

The following parameters will be measured:

1 to 4 temperatures (voltage recovery of the highest temperature) and 1 temperature default

1 direct voltage (voltage of the direct bus),

1 to 3 currents

These measures are done on the board. If you use the ARCAL-E+3P board, the measure of the temperature must be done directly on the driver boards. Thus the information you get will be resent via the ARC-MC. The information for the temperature will be that of the hottest IGBT.

All information included in this document is Arcel's or its respective authors' property. Therefore, any reproduction, use, adaptation, modification, integration, translation, commercial use, in whole or in part, by any means or any form (electronic, written or verbal) is forbidden, without prior written permission of Arcel or its respective authors.



### 3. MAXIMUM ELECTRICAL SPECIFICATIONS

Unless otherwise specified all data are given for 25°C.

Function	Symbol	Parameters	Min	Max	Unit
<i>General</i>	V <sub>in</sub>	Input voltage of power supply	18	36	V
	Viso	Test voltage of isolation (AC 50Hz, 1mn) <sup>2</sup>		2.5	kVeff
	T <sub>A</sub>	Operating temperatures	0	+70	°C
	T <sub>S</sub>	Storing temperatures	-10	+80	°C
<i>Input for the voltage measure</i>	V <sub>DC</sub>	Input voltage of Bus		1200	V
	I <sub>VDC</sub>	Input current of the voltage measure		25	mA
<i>Output of the measuring functions</i>		Max. Amplitude of U-V <sub>DC</sub>		10	V
		Max. Amplitude of U-I <sub>X</sub> : 125% of I <sub>n</sub>		10	V
		Max. Amplitude of U-Temp		10	V
<i>Default outputs</i>	ERR (X)	Default feedback of channel X (Default open collector)		40	V
	I <sub>ERR</sub> (X)	Default feedback of channel X (Collector current)		50	mA
	Over-Temp	Default feedback of temperature (Default open collector)		40	V
	I <sub>Over-Temp</sub>	Default feedback of temperature (Collector current)		50	mA

### 4. FUNCTIONAL DESCRIPTION AND ELECTRICAL SPECIFICATIONS

#### 4.1. Power supply

The power supply of the ARC-MC is provided by a DC/DC converter which supplies a ±15V output voltage. These two voltages are necessary to supply the internal circuits of the ARC-MC, the current sensors, the voltage sensor. The power of the DC/DC converter is 40W.

All information included in this document is Arcel's or its respective authors' property. Therefore, any reproduction, use, adaptation, modification, integration, translation, commercial use, in whole or in part, by any means or any form (electronic, written or verbal) is forbidden, without prior written permission of Arcel or its respective authors.



## 4.2. Electrical Specifications

Unless otherwise specified, all data are given for 25°C.

Symbol	Parameters	Conditions	Min	Typ.	Max	Unit
Vin	Power supply voltage		18	24	36	V
Iin0	Power supply current (+24V line)	Vin=24V off load		0.11		A
Iin	Power supply current (+24V line)	Vin=24V on load		0.77		A
Icc+	Available current on 15V power supply				1.4	A
Icc-	Available current on -15V power supply				1.4	A
Fc	By pass frequency of the DC/DC converter			300		kHz
	Efficiency of the DC/DC converter			87		%

## 4.3. Voltage measurement

### 4.3.1. Description of voltage measure

The direct voltage  $V_{DC}$  which has to be measured is directly applied on the ARC-MC, on the JP7 connector terminals (-HT and +HT). After processing, the ARC-MC will then release a  $U_{VDC}$  proportional voltage whose amplitude is calibrated at 9V for 100 % of the range. The voltage sensor has an insulation voltage of 2.5kV in relation to the measuring circuit of the ARC-MC.

The power supply of the voltage ranging sensor (LV25P) can be obtained owing to voltages coming from the internal power supply of the board. This measure can then be collected through the JP8 connector, by providing the power supply voltages of the sensor (+/- 15V). The choice is done through K10 and K11. However the 0V of the external power supply must be connected to 0V of the internal power supply.

### 4.3.2. Application of the voltage measure

The +HT and -HT inputs can be left open if the function isn't used. This input is optional. The measure output is protected through polarity reversal. When the connector is cabled, the  $U_{VDC}$  voltage is permanently active.

All information included in this document is Arcel's or its respective authors' property. Therefore, any reproduction, use, adaptation, modification, integration, translation, commercial use, in whole or in part, by any means or any form (electronic, written or verbal) is forbidden, without prior written permission of Arcel or its respective authors.



### 4.3.3. Electrical specifications

Unless otherwise specified all data are given for 25 °C.

Symbol	Parameters	Conditions	Min	Typ.	Max	Unit
	Measuring range	LV-25-P sensor accuracy in ARC-MC configuration		+1.6		%
	Linearity				0.2	%

### 4.3.4. Electrical specifications

This board makes it possible to measure Bus voltages up to 900V (for a 1200V IGBT) or up to 1200V (for a 1700V IGBT). This can be summarized through these 2 equations:

$$\text{IGBT 1200V (900V}_{\text{DC}} \text{ bus)} \quad \mathbf{U\_V_{DC} = 0.01 \times U\text{-bus}_{DC}}$$

$$\text{IGBT 1700V (1200V}_{\text{DC}} \text{ bus)} \quad \mathbf{U\_V_{DC} = 0.0075 \times U\text{-bus}_{DC}}$$

## 4.4. Temperature Measurement

### 4.4.1. Description and transfer function

This function is based on the variation of a resistor with Negative Temperature Coefficient (NTC). There can be several hypothetical cases for the measure of the temperature according to the driver used.

- ✓ With an ARCAL-E+3P driver: this driver is mounted on an IGBT module of type Econopack. What's more, this driver also processes the information regarding the measure of the temperature as well as the temperature default. It is therefore necessary to configure the ARC-MC in such a way that the information coming from the driver can return directly on the JP1 control connector.
- ✓ With drivers type 2106, 2315, 2210 and 2418: these drivers are not mounted with IGBT or MOS modules which have an internal NTC. It is therefore necessary to use an external temperature sensor on the heatsink (NTC = 5kΩ) and to cable it onto the JP3 connector. What's more, they have a temperature default which is compatible with the ARC-MC.

All information included in this document is Arcel's or its respective authors' property. Therefore, any reproduction, use, adaptation, modification, integration, translation, commercial use, in whole or in part, by any means or any form (electronic, written or verbal) is forbidden, without prior written permission of Arcel or its respective authors.



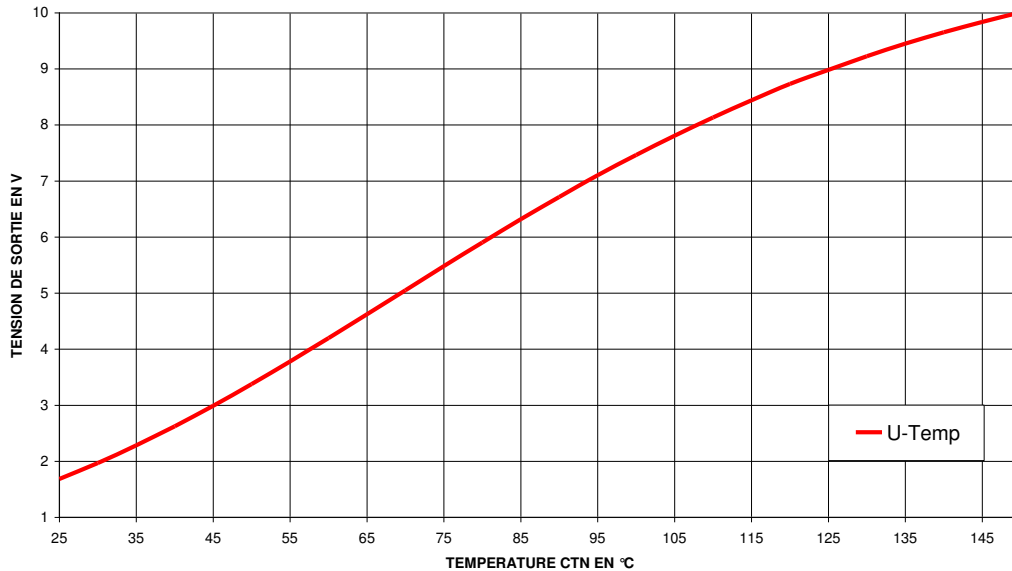

#### 4.4.2. Temperature monitoring

The temperature will be checked owing to a hysteresis comparing element connected to U-Temp. When the NTC temperature exceeds 115°C, the Over-Temp output potential (pin11) of the JP1 connector is brought back to 0V through the collector of the output transistor. This detection of temperature default (Over-Temp) is independent from the general default. The 115°C threshold can be modified upon request.

#### 4.4.3. Electrical specifications

Unless otherwise specified, all data are given for 25°C.

Symbol	Parameters	Conditions	Min	Typ.	Max	Unit
	Measuring range		0		150	°C
	Accuracy of measure	For the measuring range				°C

All information included in this document is Arcel's or its respective authors' property. Therefore, any reproduction, use, adaptation, modification, integration, translation, commercial use, in whole or in part, by any means or any form (electronic, written or verbal) is forbidden, without prior written permission of Arcel or its respective authors.



## 4.5. Measure of current

### 4.5.1. Description and transfer function

A current sensor can be connected on JP4, JP5, JP6 connectors. The measure resistance ( $R_m$ ) mounted on K4, K5 and K6 can be configured according to the sensors in use. In order to simplify the configuration, the voltage imposed on the terminals of the measure resistance  $R_m$  is 4 Volts. The gain is then  $G_v = -2$ . In this way and whatever the type of sensor is, we get a full current of 8Veff and a current default which is 125% of the rated current, i.e. 10Veff.

#### **Remark:**

As the gain is negative, it is therefore necessary to mount the sensor the wrong way round in order to get a positive  $U_{-ix}$  voltage.

- ✓  $U_{-Iu}$  Pin 22
- ✓  $U_{-Iv}$  Pin 24
- ✓  $U_{-Iw}$  Pin 26

### 4.5.2. Determination of measure resistance for Hall sensors

$K_N$  = transformer ratio

$I_p$  = primary current

$I_s$  = secondary current

$V_s$  = voltage on the terminals of the measure resistance

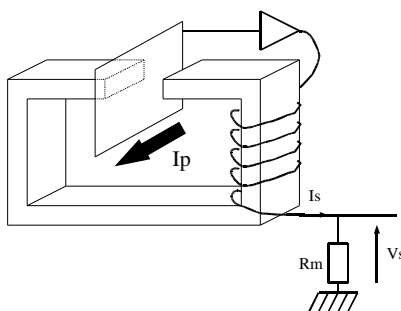

Outline 5: Simplified drawing of a Hall sensor

All information included in this document is Arcel's or its respective authors' property. Therefore, any reproduction, use, adaptation, modification, integration, translation, commercial use, in whole or in part, by any means or any form (electronic, written or verbal) is forbidden, without prior written permission of Arcel or its respective authors.



Secondary current  $I_S$  :

$$I_{S \max} = \frac{I_{P \max}}{K_N}$$

Measure resistance  $R_m$  :

$$R_m = \frac{V_{S \max}}{I_{S \max}}$$

**Remark :**

- $V_s$  must always be equal to 4Volts.
- $I_s$  depends on the sensor you use. It must be carefully calibrated in order to respect the current required by the stack.

#### 4.5.3. Determination of measure resistance for open loop sensors

For open loop sensors, a resistor higher than 10k $\Omega$  has to be installed on K4, K5 and K6. Please check that the sensor releases a 4V voltage for the maximum current which has been defined.

#### 4.5.4. Electrical specifications

Unless otherwise specified, all data are given for 25°C.

Symbol	Parameters	Conditions	Min	Typ.	Max	Unit
	Measuring range		0	+/- 10	150	°C
	Accuracy of measure	Depends on the sensor (most commonly recorded value)		+/-1		%

All information included in this document is Arcel's or its respective authors' property. Therefore, any reproduction, use, adaptation, modification, integration, translation, commercial use, in whole or in part, by any means or any form (electronic, written or verbal) is forbidden, without prior written permission of Arcel or its respective authors.



## 4.6. Pin connection of the connectors

### 4.6.1. JP1 connectors (control and power supply connectors, connectors for the measure and error signals)

Pin	Symbol	Description
1	SHIELD 1	Cable shield
2	INB U	B control for U arm
3	ERR U	Default feedback coming from U arm (C.O.)
4	INA U	A control for U arm
5	INB V	B control for V arm
6	ERR V	Default feedback coming from V arm (C.O.)
7	INA V	A control for U arm
8	INB W	B control for W arm
9	ERR W	Default return coming from W arm (C.O.)
10	INA W	A control for U arm
11	Over-Temp	Temperature default feedback (C.O.)
12		Not connected
13	$U_{DC}$	Analogue output for the direct voltage measure
14, 15	+24V	Power supply +24V
16, 17	+15V	Power +15V
18, 19, 21, 23, 25	GND	Mass
20	U-temp	Analogue output for the measure of the highest temperature
22	$U_{Iu}$	Analogue output for the measure of phase U current
24	$U_{Iv}$	Analogue output for the measure of phase V current
26	$U_{Iw}$	Analogue output for the measure of phase W current

All information included in this document is Arcel's or its respective authors' property. Therefore, any reproduction, use, adaptation, modification, integration, translation, commercial use, in whole or in part, by any means or any form (electronic, written or verbal) is forbidden, without prior written permission of Arcel or its respective authors.



#### 4.6.2. Auxiliary power supply connectors (JP2)

Pin	Symbol	Description
1	GND	Mass
2	-15V	-15V power supply
3	+15V	+15V power supply
4	+24V	+24V power supply

#### 4.6.3. X1, X2, X3 connectors (14-pin driver connectors)

Pin	Symbol	Description
1	-15V	-15V power supply
2	INB X	B control for $U_{(X1)}$ , $V_{(X2)}$ or $W_{(X3)}$ arm
3	ERR X	Default feedback coming from $U_{(X1)}$ , $V_{(X2)}$ or $W_{(X3)}$ arm (C.O.)
4	INA X	A control for $U_{(X1)}$ , $V_{(X2)}$ or $W_{(X3)}$ arm
5	Over-temp X	Default feedback coming from the measure of temperature (C.O.)
6, 7		Not connected
8, 9	+15V	+15V power supply
10, 11, 13, 14	GND	Mass
12	Temp-Out X	Analogue output for the measure of phase $U_{(X1)}$ , $V_{(X2)}$ or $W_{(X3)}$ temperature

#### 4.6.4. JP3 connector (voltage sensor)

Pin	Symbol	Description
1	-HT	Power mass
2, 3		Not connected
4	+HT	Positive terminal of measured DC voltage (up to 1000V)

All information included in this document is Arcel's or its respective authors' property. Therefore, any reproduction, use, adaptation, modification, integration, translation, commercial use, in whole or in part, by any means or any form (electronic, written or verbal) is forbidden, without prior written permission of Arcel or its respective authors.



#### 4.6.5. JP8 connector (Information about the measure of auxiliary voltage)

Pin	Symbol	Description
1	GND	Mass
2	-15V	-15V power supply of sensors
	I x	Voltage output for the measure of bus voltage coming from sensor, not processed
	+15V	+15V power supply of sensors

#### 4.6.6. JP3 connector (NTC connector)

Pin	Symbol	Description
1	1	Terminal 1 of NTC resistance
2		Terminal 2 of NTC resistance

#### 4.6.7. JP4, JP5, JP6 connectors (current sensors)

Pin	Symbol	Description
1	GND	Mass
2	-15V	-15V power supply of sensors
3	I x	Measure current input coming from sensors
4	+15V	+15V power supply of sensors

All information included in this document is Arcel's or its respective authors' property. Therefore, any reproduction, use, adaptation, modification, integration, translation, commercial use, in whole or in part, by any means or any form (electronic, written or verbal) is forbidden, without prior written permission of Arcel or its respective authors.



### 4.7. Summary table of configurations

	K1	K2	K3	K4	K5	K6	K7	K8	K9	K10	K11	K12
Grounding of the electrical 0	<b>CC</b>											
Strapp binding the JP1 15V to the ARC-MC 15V		<b>CC</b>										
Temperature default coming from ARCAL-E+3P drivers			<b>2-3</b>									
Temperature default coming from the ARC-MC board.			<b>1-2</b>									
Current measure resistances to be calculated according to sensor + gain resistance.				<b>R-m</b>	<b>R-m</b>	<b>R-m</b>						
Inhibition of temperature default done on ARC-MC							<b>CC</b>					
Inhibition of current and voltage default. Measures done on the ARC-MC								<b>CC</b>				
Use of the current sum default									<b>CC</b>			
Power supply of voltage sensor through ARC-MC board										<b>1-2</b>	<b>1-2</b>	
Power supply of voltage sensor through external power supply.										<b>2-3</b>	<b>2-3</b>	
Full scale 900V bus voltage for a 1200V IGBT												<b>CO</b>
Full scale 1200V bus voltage for a 1700V IGBT												<b>CC</b>

Remark:

- **CC** : short-circuited strapp
- **CO** : non short-circuited strapp

All information included in this document is Arcel's or its respective authors' property. Therefore, any reproduction, use, adaptation, modification, integration, translation, commercial use, in whole or in part, by any means or any form (electronic, written or verbal) is forbidden, without prior written permission of Arcel or its respective authors.



**4.8. Mechanical data and connector tracking, configuration strapps**

6 fixing holes: Ø 4mm

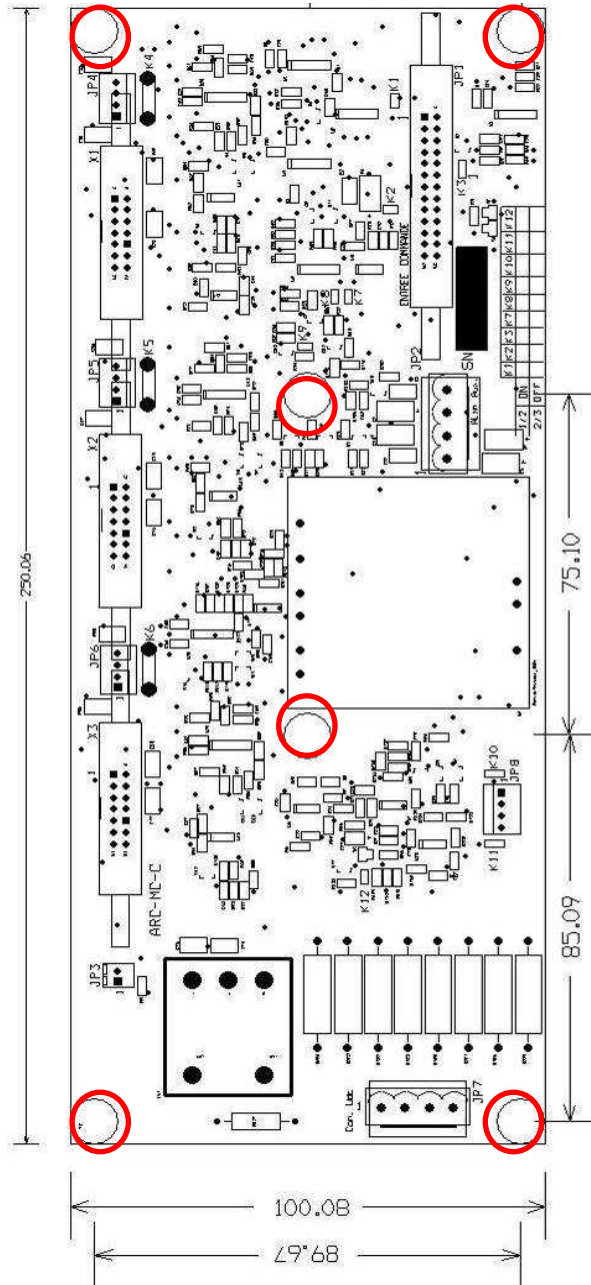

All information included in this document is Arcel's or its respective authors' property. Therefore, any reproduction, use, adaptation, modification, integration, translation, commercial use, in whole or in part, by any means or any form (electronic, written or verbal) is forbidden, without prior written permission of Arcel or its respective authors.

