

ARCCENTRA

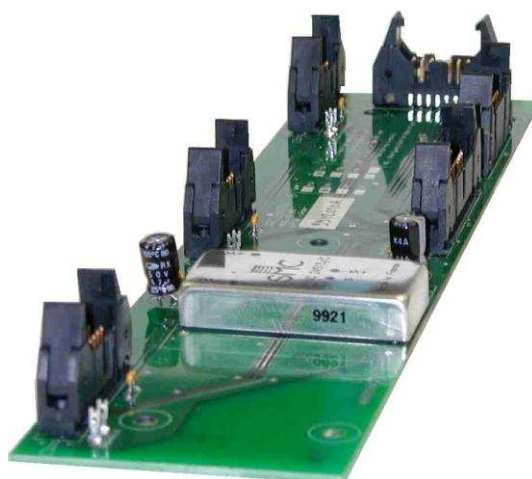

Data warehousing board for the supervision of 1 to 4 IGBT or MOSFET drivers

The ARCCENTRA board is a data interface for IGBT and MOSFET drivers which dispatches the power supply, control and error signals from one single connector to 3 or 4 self-functioning channels. A power supply matching to 15V is also available on the ARCCENTRA, with a power output up to 25W as well as the possibility to drive a fourth driver or a brake. You can also have an input for monitoring and alarm signals (temperature, voltage, current...) to be used with measure devices such as the ARCTU3I board.

- **Connector technology to DIN41651 format**
- **Input : 1 x 26-pin connector**
Output : 4 x 14-pin connectors
- **1 x 20-pin connector for monitoring and error signals**
- **Power supply from 10 to 25W**
- **Input voltage 18 to 36V**
Output voltage : 15V regulated
- **Large range of temperature -40 to +85 °C**
- **Complete compatibility with ARCAL2106, ARCAL2315 and ARCTU3I boards**



All information included in this document is Arcel's or its respective authors' property. Therefore, any reproduction, use, adaptation, modification, integration, translation, commercial use, in whole or in part, by any means or any form (electronic, written or verbal) is forbidden, without prior written permission of Arcel or its respective authors.



CONTENTS

1.	Options available	2
2.	Functional Drawing	3
3.	Maximum Electrical Specifications	3
4.	Electrical Specifications	4
5.	Pin configuration	5
6.	Overview.....	8

1. OPTIONS AVAILABLE

Options		References
Voltage conversion	18W	ARCCENTRA-18C
	Without voltage conversion	ARCCENTRA-01C
With auxiliary channel	With aux. without conversion	ARCCENTRA-01CX
	With aux. and conversion	ARCCENTRA-18CX

Remark : we can provide other power values, for more information please contact us.

All information included in this document is Arcel's or its respective authors' property. Therefore, any reproduction, use, adaptation, modification, integration, translation, commercial use, in whole or in part, by any means or any form (electronic, written or verbal) is forbidden, without prior written permission of Arcel or its respective authors.



2. FUNCTIONAL DRAWING

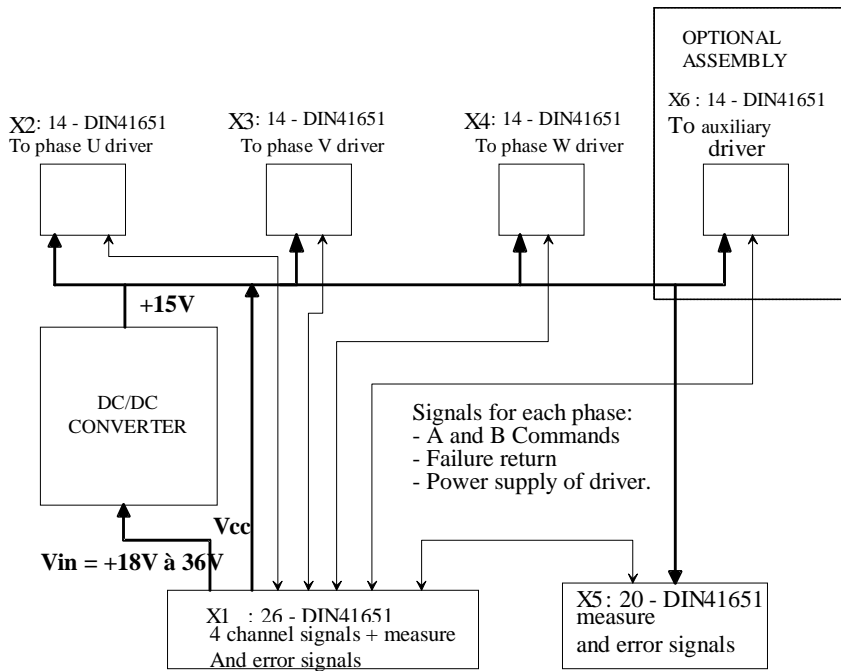

3. MAXIMUM ELECTRICAL SPECIFICATIONS

Unless otherwise specified all the following specifications are given for 25° C.

	Symbol	Parameters	Min.	Max.	Unit
VOLTAGE CONVERSION	V_{in}	Unregulated power supply input voltage ⁱ		36	V
CONNECTORS	V_p	Max. DC voltage on one pin ⁱⁱ		75	V
	I_p	Max. current on one pin		1	A
	V_{cc}	Regulated power supply (Without adaptation of power supply) ⁱ		50	V
GÉNÉRAL	T_a	Operating temperature	-40	+85	°C
	T_s	Storage temperature	-40	+100	°C

All information included in this document is Arcel's or its respective authors' property. Therefore, any reproduction, use, adaptation, modification, integration, translation, commercial use, in whole or in part, by any means or any form (electronic, written or verbal) is forbidden, without prior written permission of Arcel or its respective authors.



4. ELECTRICAL SPECIFICATIONS

The electrical specifications regarding the adaptation of the power supply are available at ARCEL, please contact us for additional information.

All information included in this document is Arcel's or its respective authors' property. Therefore, any reproduction, use, adaptation, modification, integration, translation, commercial use, in whole or in part, by any means or any form (electronic, written or verbal) is forbidden, without prior written permission of Arcel or its respective authors.



5. PIN CONFIGURATION

X1 : Connector for the control, power supply + measure and error signals

Pin	Symbol	Description
1	SHIELD	Cable shield
2	INB_U	B control signal for the arm of phase U
3	ERR_U	Arm U error return (Collector open)
4	INA_U	A control signal for the arm of phase U
5	INB_V	B control signal for the arm of phase V
6	ERR_V	Arm V error return (Collector open)
7	INA_V	A control signal for the arm of phase V
8	INB_W	B control signal for the arm of phase W
9	ERR_W	Arm W error return (Collector open)
10	INA_W	A control signal for the arm of phase W
11	OVER_TEMP / ERR_X	Temperature warning signal (C.O.) or error return for the auxiliary arm ⁱⁱⁱ
12	ERR_MES	Error return of measuring board (C.O.) ^{iv}
13	U_Vdc	Analogue output of direct power measure ^{iv}
14, 15	Vin	Unregulated power supply (from 18 to 36V)
16, 17	Vcc	Regulated power supply 15V +/- 4%
18, 19	GND	Ground
20	INB_X / U_TEMP	B signal for the arm of the auxiliary phase or analogue output of the temperature measurement ⁱⁱⁱ
21	INA_X / GND	A signal for the arm of the auxiliary phase or exposed conductive part ⁱⁱⁱ
22	U_Iu	Analogue output of the current measure for phase U ^{iv}
23	GND	Ground
24	U_Iv	Analogue output of the current measure for phase V ^{iv}
25	GND	Ground
26	U_Iw	Analogue output of the current measure for phase W ^{iv}

All information included in this document is Arcel's or its respective authors' property. Therefore, any reproduction, use, adaptation, modification, integration, translation, commercial use, in whole or in part, by any means or any form (electronic, written or verbal) is forbidden, without prior written permission of Arcel or its respective authors.



X2, X3, X4: Connectors for the control of the half-arm drivers

X2 : phase U ; X3 : phase V ; X4 : phase W.

Pin	Symbol	Description
1	SHIELD	Cable shield
2	INB	B control for the arm
3	ERR	Arm error return (Collector open)
4	INA	A control for the arm
8, 9	Vcc	Regulated power supply 15V
10, 11	GND	Ground
5, 6, 7, 12,13,14		Not connected

X6: Connector for the control of an auxiliary driver or a brake

Pin	Symbol	Description
1	SHIELD	Cable shield
2	INB	B control for the arm
3	ERR	Arm error return
4	INA	A control for the arm
5	U_Vdc	Analogue output of the direct power measure
6, 7	Vin	Unregulated power supply (18-36V)
8, 9	Vcc	Regulated power supply 15V
10, 11	GND	Ground
12,13,14		Not connected

All information included in this document is Arcel's or its respective authors' property. Therefore, any reproduction, use, adaptation, modification, integration, translation, commercial use, in whole or in part, by any means or any form (electronic, written or verbal) is forbidden, without prior written permission of Arcel or its respective authors.



X5 : Connector for the measurement and monitoring system

Pin	Symbol	Description
1	SHIELD	Cable shield
2, 3		Not connected
4	OVER_TEMP	Temperature warning signal (C.O.)
5	ERR_MES	Error return of the measuring board (C.O.)
6	U_Vdc	Analogue output of the direct power measure
7	GND	Ground
8, 9	Vin	Unregulated power supply (from 18 to 36V)
10, 11	Vcc	Regulated power supply 15V +/- 4%
12, 13	GND	Exposed conductive part
14	U_TEMP	Analogue output of the temperature measure
15	GND	Ground
16	U_Iu	Analogue output of the current measure for phase U
17	GND	Ground
18	U_Iv	Analogue output of the current measure for phase V
19	GND	Ground
20	U_Iw	Analogue output of the current measure for phase W

All information included in this document is Arcel's or its respective authors' property. Therefore, any reproduction, use, adaptation, modification, integration, translation, commercial use, in whole or in part, by any means or any form (electronic, written or verbal) is forbidden, without prior written permission of Arcel or its respective authors.



6. OVERVIEW

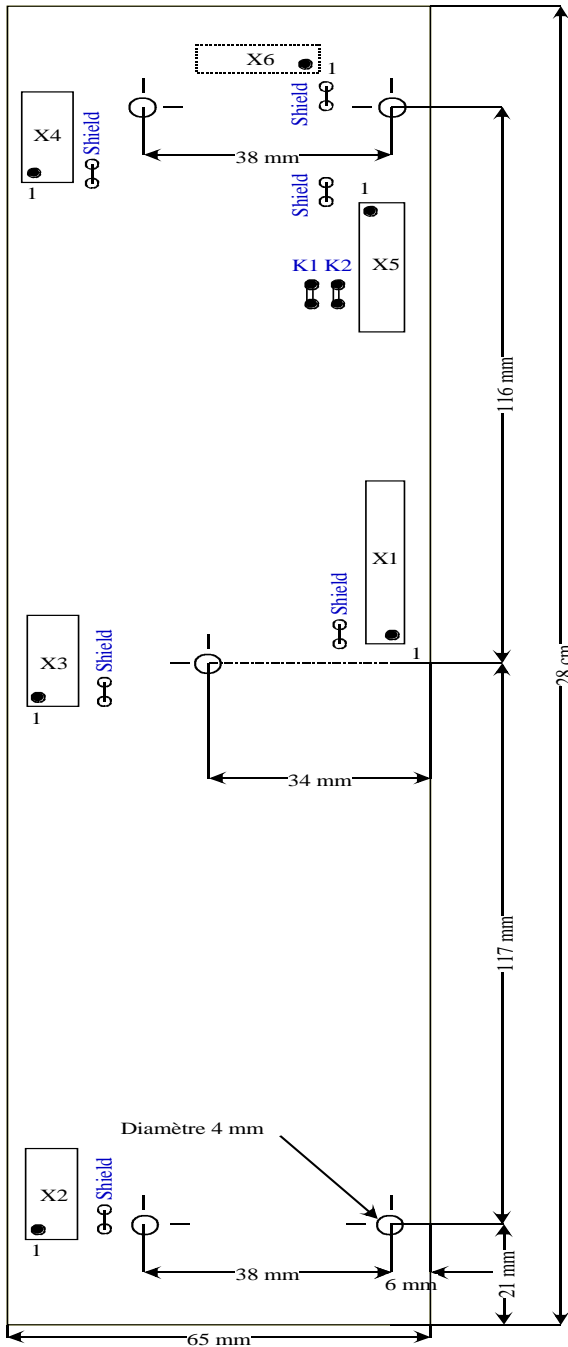

Remarks :

- Operation with the auxiliary arm connected on X6 :
 - K1 and K2 straps must be removed.
 - When using the control channels of the auxiliary arm, the temperature measuring function of the ARCTU3I board is no longer accessible.
- For the options with voltage conversion, the Vcc input mustn't be supplied (X1 : pins 16 and 17).
In this configuration, these pins offer a 15V voltage which can be used within the limits of the available power.
- The «Shield» straps offer a connection between the potential cable shield and the exposed conductive part of the board. In the standard configuration they are not connected. It's up to you to connect them if you want to do it.

Dimensions : 275 mm x 65 mm

Thickness : 25 mm

Weight : 180 grammes

All information included in this document is Arcel's or its respective authors' property. Therefore, any reproduction, use, adaptation, modification, integration, translation, commercial use, in whole or in part, by any means or any form (electronic, written or verbal) is forbidden, without prior written permission of Arcel or its respective authors.



 Before printing think about **environment and costs!** N'imprimez ce document que si nécessaire.

CAUTION : ARCEL se réserve le droit d'apporter des modifications à sa documentation technique sans avertissement au préalable. Ces documents n'ont aucun caractère contractuel

-
- ⁱ Voltages given according to the exposed conductive part of the assembly (GND Signal).
 - ⁱⁱ Except Vin and Vcc signals.
 - ⁱⁱⁱ According to the chosen option :
 - option «X » (auxiliary) : signals of the auxiliary arm.
 - other options : measure and error signals for the temperature.
 - ^{iv} Signals generated by a potential board connected to X5.

All information included in this document is Arcel's or its respective authors' property. Therefore, any reproduction, use, adaptation, modification, integration, translation, commercial use, in whole or in part, by any means or any form (electronic, written or verbal) is forbidden, without prior written permission of Arcel or its respective authors.

