ARCAL 2315



Dual IGBTs and MOSFETs Driver "SCALE TECHNOLOGY"

The ARCAL2315 board is an intelligent double IGBTs and MOSFETs driver.

All functions needed for power converters development are embedded on a small size, very versatile single board.

- **High insulation and dv/dt immunity**
- **3W / $\pm 15A$ per output**
- **Short-circuit protection**
- **Power supply monitoring**
- **high or low logic error feedback**
- **CMOS or HCMOS input level**
- **Tuneable dead time**
- **$\pm 15V$ or $0/+15V$ Gate voltage**
- **Turn-On and Turn-Off control**

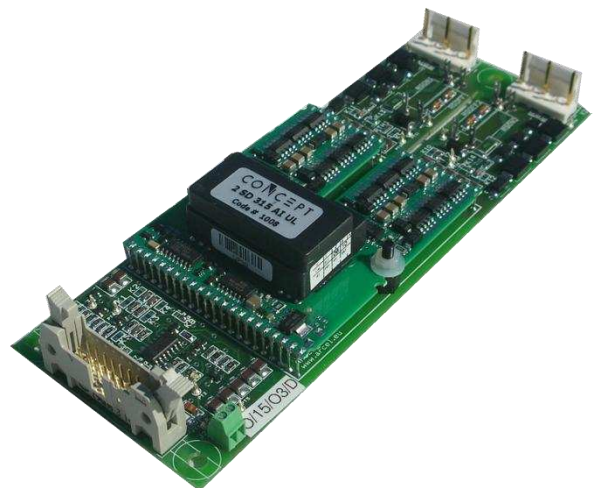

All information included in this document is Arcel's or its respective authors' property. Therefore, any reproduction, use, adaptation, modification, integration, translation, commercial use, in whole or in part, by any means or any form (electronic, written or verbal) is forbidden, without prior written permission of Arcel or its respective authors.



Contents

1. Absolute Maximum Ratings	3
2. electrical Characteristics	3
2.1. Power Supplies	3
2.2. Input stage	4
2.3. Output stage	4
3. Block Diagram	5
4. Mechanical Data	6
5. Overview	7
6. Detailed Description	8
6.1. Driver supplies	8
6.2. Shielding (K6)	8
6.3. Operating Modes (K8)	8
6.4. Logic inputs (K5)	12
6.5. Default feedback signal (K7)	13
6.6. Gate control	14
6.7. Short-circuits monitoring (K9, K10)	15
6.8. Power supplies monitoring	16
7. CONFIGURATION: abstract table	17

All information included in this document is Arcel's or its respective authors' property. Therefore, any reproduction, use, adaptation, modification, integration, translation, commercial use, in whole or in part, by any means or any form (electronic, written or verbal) is forbidden, without prior written permission of Arcel or its respective authors.



1. ABSOLUTE MAXIMUM RATINGS

All data refer to 25°C and VDD=15V unless otherwise specified.

Symbol	Parameter	Min.	Max.	Unit
VDD	Supply voltage (referred to ground) ⁱ	0	16	VDC
VI	Logic input voltage	0	VDD	VDC
IG	Peak Gate current	-15	+15	A
PG	Output power for each channel ⁱⁱ		3	W
VISO	Isolation test voltage (AC / 50Hz / 1min)		4000	Veff
VOP	Operating voltage ⁱⁱⁱ		1200	VDC
dv/dt	dv/dt immunity @ ΔV=1000V	100		KV/μs
TA	Operating temperature	-40	+85	°C
TS	Storage temperature	-40	+90	°C
VOC	Error feedback open collector max. voltage		40	V
IOC	Error feedback open collector max. current		10	mA

2. ELECTRICAL CHARACTERISTICS

All data refer to 25°C and VDD=15V unless otherwise specified.

2.1. Power Supplies

Symbol	Parameter	Min.	Typ.	Max.	Unit
VDD	Nominal supply voltage	14.5	15	15.5	VDC
IDD ₀	No-load max. supply current ^{iv}		90		mA
IDC ₀	DC/DC converter no-load input current		30		mA
IDD	Max. supply current ^v		531		mA
η	DC/DC converter efficiency		85		%
VTH ₀	power supply monitoring threshold voltage ^{vi}		11.5		V
H	Power supply monitoring hysteresis ^{vi}		0.7		V

All information included in this document is Arcel's or its respective authors' property. Therefore, any reproduction, use, adaptation, modification, integration, translation, commercial use, in whole or in part, by any means or any form (electronic, written or verbal) is forbidden, without prior written permission of Arcel or its respective authors.



2.2. Input stage

Symbol	Parameter	Min.	Typ.	Max.	Unit
VIM	Max. logic input voltage ⁱ	0		VDD	V _{DC}
VIT+	Low to High input threshold voltage (5V/15V)		3.4/10		V
VIT-	High to Low input threshold voltage (5V/15V)		1.7/5		V
F _{SW}	Switching frequency ^{vii}	0		>100	KHz
α	Duty cycle	0		100	%
R _{IN}	Input resistance ^{viii}	10	15		KΩ
T _{DT}	Standard dead time ^{ix}		5		μs

2.3. Output stage

Symbol	Parameter	Min.	Typ.	Max.	Unit
I _G	Max. gate current	-15		+15	A
V _{G+}	Turn-on gate output voltage		+15		V
V _{G-}	Turn-off gate output voltage		-15/0		V
T _R	Rise time ^x		110/160		ns
T _F	Fall time ^x		80/130		ns
TPD+	Input / output turn-on delay time		300		ns
TPD-	Input / output turn-off delay time		350		ns
T _B	Blocking time after failure		1		s
T _{ER}	Default feedback duration ^{xi}		6		ms
T _{CE}	VCE monitoring reaction time ^{ix}		10.4		μs
V _{THX}	VCE monitoring threshold voltage ^{xii}		8.2/6.6		V

All information included in this document is Arcel's or its respective authors' property. Therefore, any reproduction, use, adaptation, modification, integration, translation, commercial use, in whole or in part, by any means or any form (electronic, written or verbal) is forbidden, without prior written permission of Arcel or its respective authors.



3. BLOCK DIAGRAM

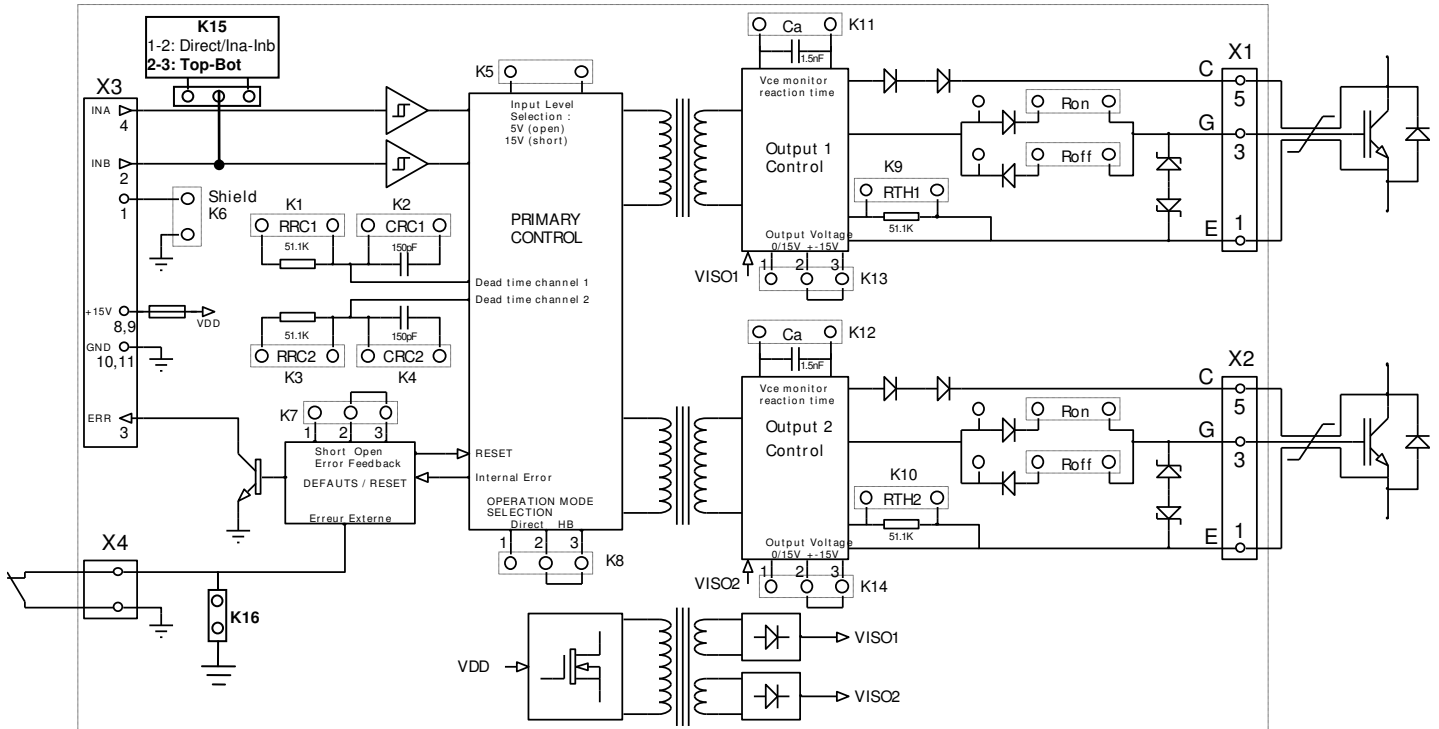

X3 : 14-DIN41651

X1,X2 : MOLEX 41791

X4 : Phoenix Contact NPT0.5/2-2.54 (screwed)^{xiii}

All information included in this document is Arcel's or its respective authors' property. Therefore, any reproduction, use, adaptation, modification, integration, translation, commercial use, in whole or in part, by any means or any form (electronic, written or verbal) is forbidden, without prior written permission of Arcel or its respective authors.



4. MECHANICAL DATA

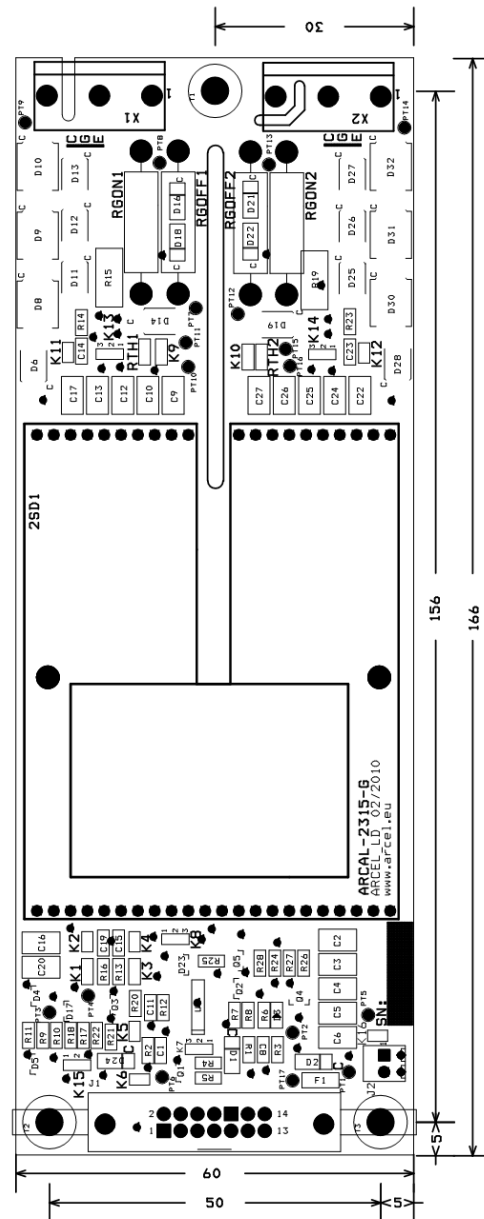

Max. height : 30 mm

All information included in this document is Arcel's or its respective authors' property. Therefore, any reproduction, use, adaptation, modification, integration, translation, commercial use, in whole or in part, by any means or any form (electronic, written or verbal) is forbidden, without prior written permission of Arcel or its respective authors.



5. OVERVIEW

ARCAL2315 driver is based on SCALE (Scalable, Compact, All purpose, Low cost and Easy to use) module, last driver generation, distinguished as "best project in power electronics 1998" by ABB Switzerland AG.

All the necessary functions for a **safe** IGBTs control are embedded on a single board. Each parameter depending on the application can be adjusted by the end user.

Main characteristics

- ARCAL2315 driver allows 2 IGBTs (or MOSFETs) driving as a half-bridge or as two independent switches. ARCAL2315 drives all IGBTs with VCE up to 1700V. If a single IGBT is used, terminals C and E of the unused output must be shorted.
- IGBTs (MOSFETs) gate voltage is $\pm 15V$ and 0/15V in standard version.
- IGBTs (MOSFETs) protection is set by Vcesat (VDSon) and secondary side power supplies monitoring.
- A single +15V supply is required. Required isolated power supplies are generated.
- All logic inputs are Schmitt trigger type. Their input level can be selected to 5V (HCMOS) or 15V (CMOS).
- The dead time of each output can be tuned independently.
- The error feedback signal can be activated by the driver (short-circuit or under voltage) or by an external signal.
- The connectors have been selected for their reliability and to simplify the driver implementation in existing applications.
- An "Active Clamping" voltage protection is set by collector voltage monitoring.

All information included in this document is Arcel's or its respective authors' property. Therefore, any reproduction, use, adaptation, modification, integration, translation, commercial use, in whole or in part, by any means or any form (electronic, written or verbal) is forbidden, without prior written permission of Arcel or its respective authors.



6. DETAILED DESCRIPTION

6.1. Driver supplies

ARCAL2315 driver needs a regulated +15V ±0.5V DC supply voltage. The maximum power consumption is about 8W.

The input supply current can be estimated by the following formula:

$$I_{DD} (A) \approx \frac{P_{GT} (W)}{0.85 \times 15} + 0.060$$

Where: P_{GT} = total power provided to IGBTs by the driver.

Remark:

Due to high power pulses required in such applications, the DC/DC converters are not protected against overload. Nevertheless, the short-circuit row up are limited by a fuse.

6.2. Shielding (K6)

If a shielded cable is used, it can be connected to pin X3.1 and coupled to the board ground through a short-circuit, a resistor or a capacitor on **K6**.

6.3. Operating Modes (K8)

ARCAL2315 driver can operate on two modes:

- "DIRECT" mode allows driving separately the two outputs.
- "HB" mode allows driving a half-bridge structure.

All information included in this document is Arcel's or its respective authors' property. Therefore, any reproduction, use, adaptation, modification, integration, translation, commercial use, in whole or in part, by any means or any form (electronic, written or verbal) is forbidden, without prior written permission of Arcel or its respective authors.



Direct Mode

In this mode, both outputs are driven separately by InA and InB inputs. Nevertheless, the various securities still stop both outputs and activate the error feedback signal.

A high level on Inx input turns on the corresponding output. Ina drives the BOT IGBT (connected on X2).

Because the two outputs are independent, no dead time is generated. Thus, it is possible to switch on both outputs at the same time.

The DIRECT MODE configuration is selected by linking pins 1 and 2 of K8 and K15 and short-circuiting K2 and K4.

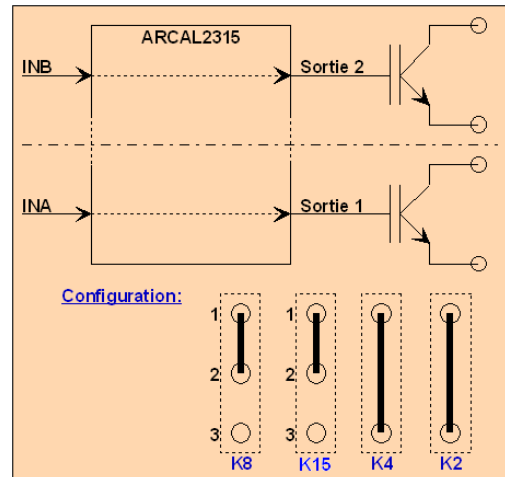

Caution:

A driver dysfunction can occur if K2 and K4 are not short-circuited in DIRECT MODE operation!

HB Mode and Dead Time (K1 à K4)

Half-bridge mode is especially dedicated to structures where two IGBTs operate in series as complementary switches (eg. inverters, H bridges ...).

In this case, both outputs are not independent anymore: InA input allows the half-bridge control and InB output operates as an "enable" signal.

A low level on InB forces both outputs off, whatever InA level.

When InB is high, outputs levels depend on InA.

Because the two switches are in series connection, a dead time must be applied to make sure no transient short-circuit occurs.

The end user can modify the dead time value of output 1 with K1/K2 (RRC1/Crc1), and output 2 with K3/K4 (RRC2/Crc2). The standard value is about. 5µs



The following figure allows the determination of R_p resistor to be used on **K1** and/or **K3**, in two cases: without any added capacitor C_p on **K2** and **K4** or with a $C_p=150pF$ capacitor on **K2** and **K4**.

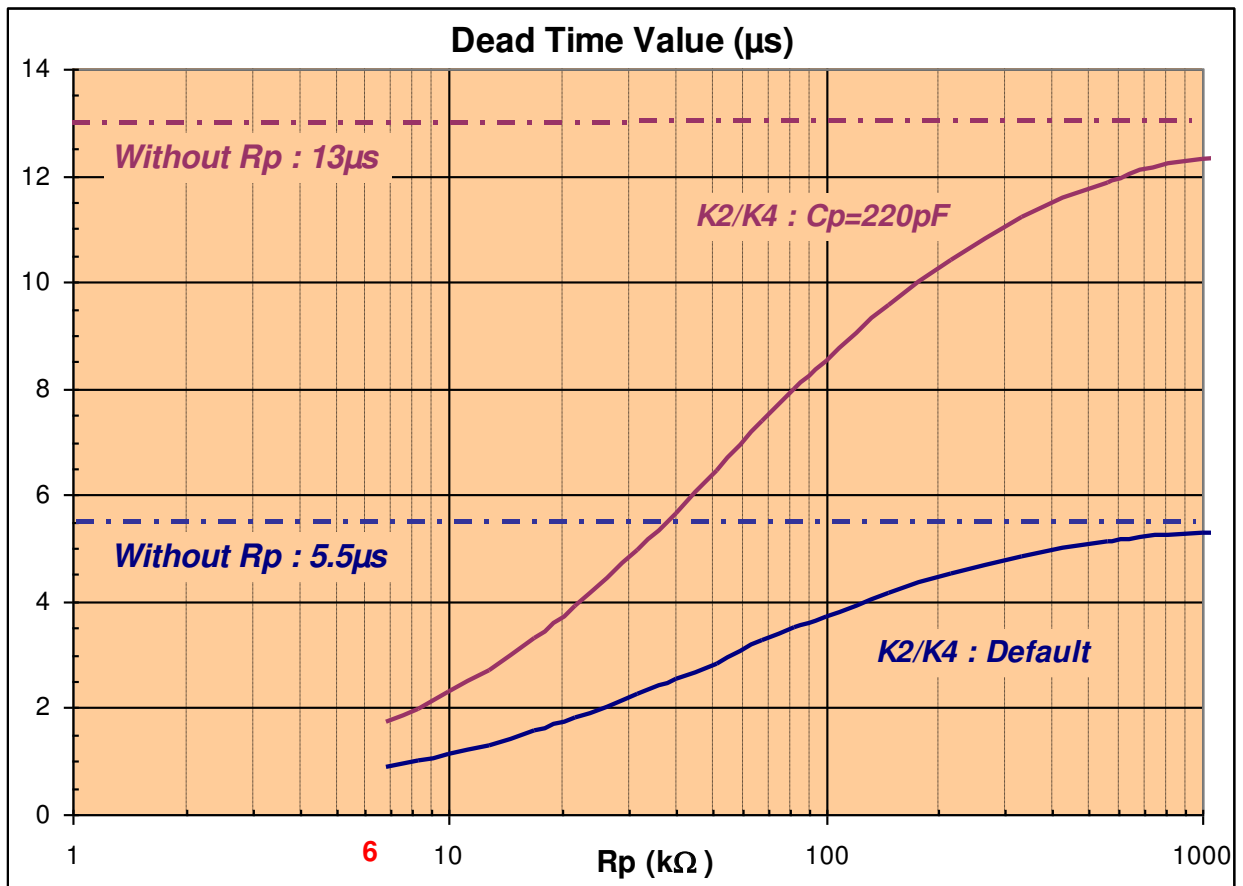

Caution:

R_p resistor must never be lower than 6k Ω .

All information included in this document is Arcel's or its respective authors' property. Therefore, any reproduction, use, adaptation, modification, integration, translation, commercial use, in whole or in part, by any means or any form (electronic, written or verbal) is forbidden, without prior written permission of Arcel or its respective authors.



HB mode selection

Standard configuration is HB mode, set by short-circuiting pins 2-3 of **K8**. Ina drives the TOP IGBT (connected on **X1**).

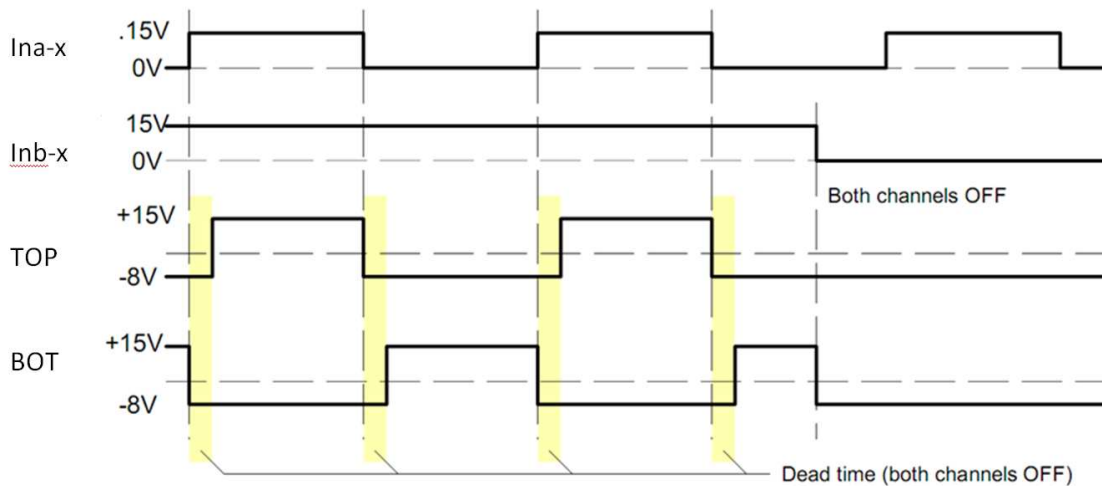

HB mode with dead time generation

TOP-BOT or Ina-Inb HB Mode

The TOP-BOT mode enables to send complementary signals Ina-x and Inb-x, in order to generate the “start/stop” signal on Inb channel from these two signals. It is the selected mode on standard configuration (pins 2-3 of **K15** linked).

Ina-Inb mode enables to send directly a Start/Stop signal on Inb channel from Inb-x (pins 1-2 of **K15** linked).



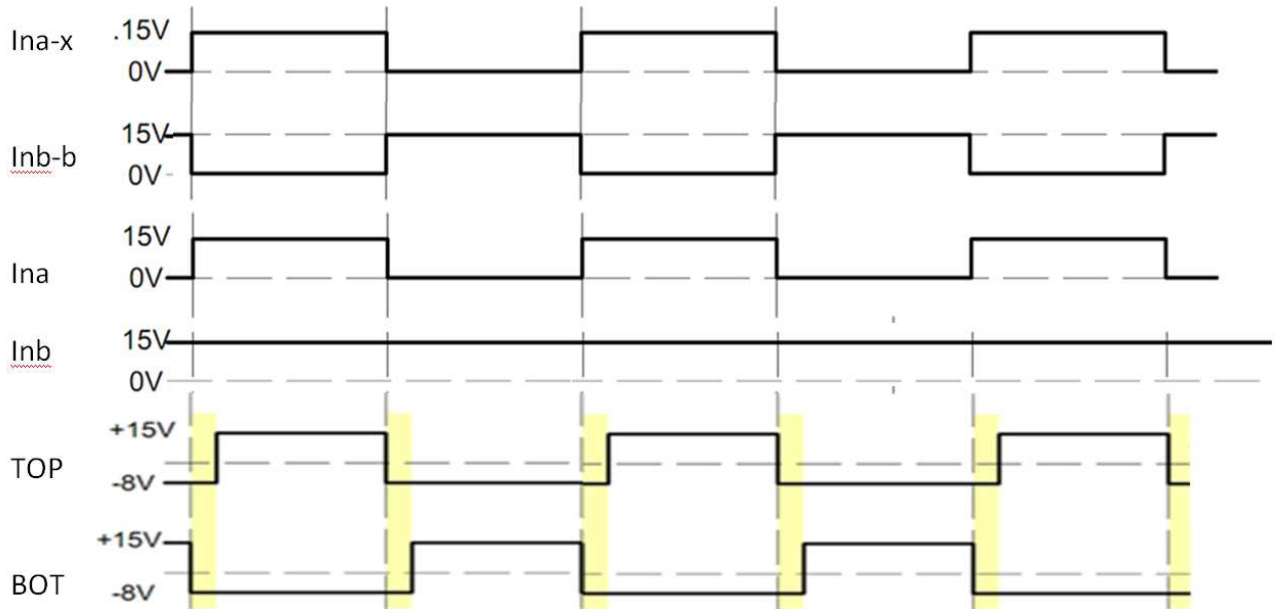

Input and output Signals with TOP-BOT configuration

NOTE : Ina-x et Inb-x refers to the output orders on X3 and Ina and Inb to the input orders in the driver.

6.4. Logic inputs (K5)

InA and InB inputs are Schmitt trigger type. The threshold voltages are about $1/3^{\text{rd}}$ and $2/3^{\text{rd}}$ of the selected level voltage (CMOS or HCMOS). A high level corresponds to an active input.

0/5V (HCMOS compatible) inputs are selected by linking **K5** pins. Otherwise, 0/15V (CMOS compatible) inputs are selected.

The input stage has protection diodes on each channel. If the input level goes below 0V or exceeds VDD, this protection can be subject to overload. Particular care must be taken when driving via cables or longer leads.

In nominal conditions the inputs impedance is about 15kΩ.

All information included in this document is Arcel's or its respective authors' property. Therefore, any reproduction, use, adaptation, modification, integration, translation, commercial use, in whole or in part, by any means or any form (electronic, written or verbal) is forbidden, without prior written permission of Arcel or its respective authors.



6.5. Default feedback signal (K7)

The default feedback signal is open collector type. It can support 40V and 10mA. An external pull-up resistor must be provided.

K7 allows the default mode selection:

- **Low logic:** pins 1 and 2 are linked. In this case, a default will close the output transistor (it will sink current).
- **High logic:** pins 2 and 3 are linked. In this case, a default will open the output transistor (it stops sinking current). This is the default mode of the driver. We recommend using this mode because it will naturally take into account a bad connection of the default wire to the main board.

The default signal can be activated by two different events:

- **Internal error:** a short-circuit on an output or a supply problem has occurred.
- **External error:** X4 input is high impedance. This input can be used to connect an external element such as a bimetal thermal trip for the heatsink over-temperature monitoring. If not used, **K16** must be shorted.

Internal error case

In the internal error case, the default feedback signal will be activated during about 6ms. The driver will automatically reset and both outputs will stay in the off state during approximately 1s.

The main control system is supposed to stop all driving pulses as soon as an error signal occurs. If not, and after the default feedback signal has been reset, short pulses (about 10µs) can occur on the non-default output and the error feedback will be set for 6ms more ... etc. This will go on until the default cause has disappeared or driving pulses have been stopped.

Remark

The internal default monitoring is achieved directly on the secondary side for each output. So a default detection will immediately stop the concerned output during approximately 1s. But the error feedback will only occur on the changing edge of Inx inputs (or InA in HB mode).

After the blocking time, the driver will start over only on a rising edge of the concerned input (or InA in HB mode).

All information included in this document is Arcel's or its respective authors' property. Therefore, any reproduction, use, adaptation, modification, integration, translation, commercial use, in whole or in part, by any means or any form (electronic, written or verbal) is forbidden, without prior written permission of Arcel or its respective authors.



External error case (X4)

The **X4** connector can receive a dry contact or an open collector signal. The permanent current is approximately of 150µA with a 30mA peak corresponding to a capacitor discharge.

The driver will consider an open circuit (or high impedance) as a default. The default feedback will be activated until the circuit is closed and will stay activate approximately 6ms after.

Both outputs are forced to off state during the whole default feedback duration and the driver will start over only on a rising edge of Inx inputs (or InA in HB mode).

The two pins of **X4** must be shorted by short-circuiting **K16** if not used.

Power on

At the power on, the default feedback signal is systematically activated for about **Erreur ! Source du renvoi introuvable.ms** for the auxiliary power supplies stabilisation.

6.6. Gate control

The standard version of ARCAL2315 provides a ±15V **and** 0/15V gate voltage. The selection is made as follows:

- **±15V**: link pins 1 and 2 of **K13** (output 1) and/or **K14** (output 2).
- **0/15V**: link pins 2 and 3 of **K13** (output 1) and/or **K14** (output 2).

For each output, the turn-on and turn-off can be controlled independently by 2 gate resistors: **Ron** and **ROFF**.

However, two more pins are available for using with a single gate resistor.

The resistor value depends on the IGBT manufacturer recommendations and on the application.

Peak current (Rg1, Rg2)

The peak gate current depends on the total impedance of the gate loop. it can be estimated by the following formula :

$$I_{GP}^{ON} (A) = \frac{\Delta V_{GE} (V)}{R_{GON} (\Omega)} \quad \text{et} \quad I_{GP}^{OFF} (A) = \frac{\Delta V_{GE} (V)}{R_{GOFF} (\Omega)}$$



Where: ΔV_{GE} gate voltage variation (here 30V or 15V).

R_{GON} turn-on gate resistor

R_{GOFF} turn-off gate resistor

The current I_{GP} must never exceed 15A. Thus, the theoretic lower R_G resistor value is 2Ω (for $\pm 15V$ gate voltage) or 1Ω (for 0/15V gate voltage).

Average power

The average power P_G on a driver output depends on the total gate charge Q_G , the gate voltage ΔV_{GE} and the switching frequency F_{SW} :

$$P_G = Q_G \times \Delta V_{GE} \times F_{SW}$$

This power must never exceed 3W.

6.7. Short-circuits monitoring (K9, K10)

For short-circuit detection, the IGBT V_{CEsat} is compared to a reference voltage. If the V_{CEsat} exceeds the reference voltage, a short-circuit is detected.

To fit the switching waveform of IGBTs, the reference voltage is not constant :

First, the short-circuit detection stays inactive during the response time T_{ce} . Afterwards, the detection becomes active and the reference voltage starts decreasing from V_{TH1} to V_{TH2} in approximately $15\mu s$.

For each output, T_{CE} and V_{TH} can be adjusted with a R_{th} resistor on **K9** (output 1) and **K10** (output 2) and/or a CA capacitor on **K11** (output 1) and **K12** (output 2).

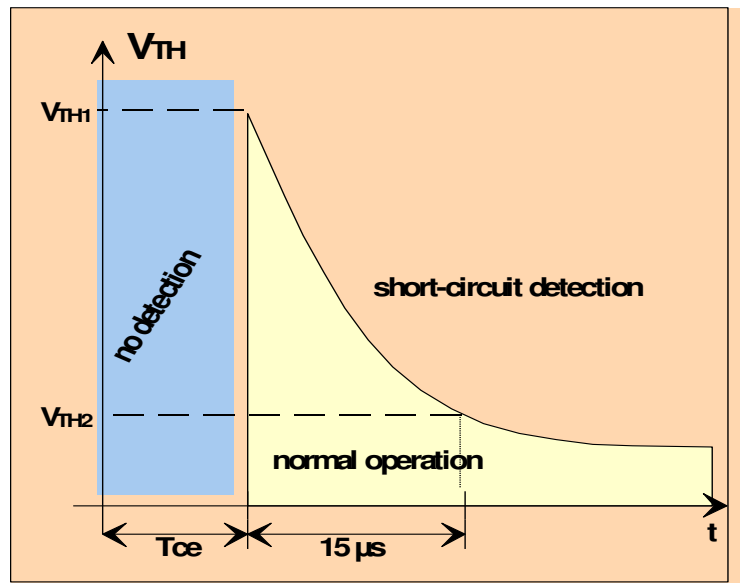

All information included in this document is Arcel's or its respective authors' property. Therefore, any reproduction, use, adaptation, modification, integration, translation, commercial use, in whole or in part, by any means or any form (electronic, written or verbal) is forbidden, without prior written permission of Arcel or its respective authors.



The following table gives some parameters set values in function of the RTH resistor used. TCE value changes in proportion of CA value, whereas the threshold voltages VTH1 and VTH2 remain practically unchanged. The table is given for the default CA value of 1.5nF.

RTH	TCE	VTH1	VTH2
default	10.4 μs	8.2 V	6.6 V
180 K Ω	8.8 μ s	6.9 V	4.8 V
82 K Ω	7.5 μ s	5.6 V	3.5 V
39 K Ω	6.2 μ s	4 V	2 V

Tableau 1 : RTH selection for short-circuit detection

6.8. *Power supplies monitoring*

The power supplies monitoring is realised directly on the secondary side, for each output. If one of the auxiliary power supplies becomes lower than 11.5V, the concerned output is turned off and the default signal is activated.

The under-voltage detection has a hysteresis of 0.7V. Thus the driver will start over only if the auxiliary voltage exceeds 12.2V.



 Before printing think about **environment** and **costs!** N'imprimez ce document que si nécessaire.

-
- ⁱ The system is protected by zener and bipolar diodes. Exceeding those values may result in an overheating and/or overload. Special care must be taken when using long connection lines.
 - ⁱⁱ Available power on DC/DC converter outputs.
 - ⁱⁱⁱ Maximum continuous or repeatedly applied DC voltage or peak value of the repeatedly applied AC voltage between all inputs and all outputs. However, types that have been measured and selected for higher partial-discharge voltages can be provided. The partial discharge is not measured for the standard types.
 - ^{iv} For 25KHz driving signals.
 - ^v If the output max. power is exceeded, the DC/DC converter will be in overload.
 - ^{vi} For IGBTs protection. Each auxiliary voltage is monitored.
 - ^{vii} With respect to the max. output power.
 - ^{viii} In nominal operating conditions.
 - ^{ix} Tuneable by the end user.
 - ^x First value : with a load of 5.6Ω in series with 39nF.
Second value : with a load of 1.8Ω in series with 250nF.
 - ^{xi} Except for external default input (X4) activation.
 - ^{xii} Tuneable by the end user. First value corresponds to the threshold after response time and second value corresponds to the threshold final value (approximately 15 μ s later).
 - ^{xiii} Except for series 9912XXX-B, where X4 : MOLEX Mini KK 6410/7395 – 2pin.

All information included in this document is Arcel's or its respective authors' property. Therefore, any reproduction, use, adaptation, modification, integration, translation, commercial use, in whole or in part, by any means or any form (electronic, written or verbal) is forbidden, without prior written permission of Arcel or its respective authors.

