

AR332

- ✓ Heatsink for stud component
- ✓ Weight : 3,62 Kg/m
- ✓ Application : natural cooling
- ✓ Plating : contact us
- ✓ available length on stock : 1500 mm
- ✓ Machining and assemblies on request

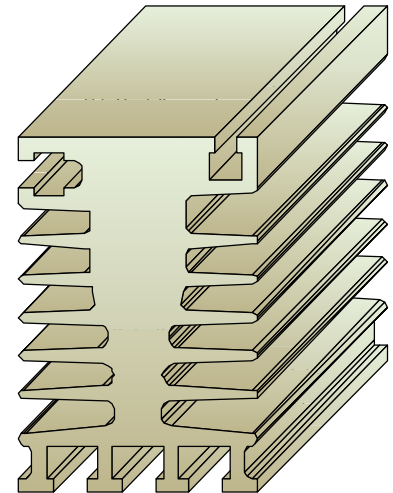

Dimensions

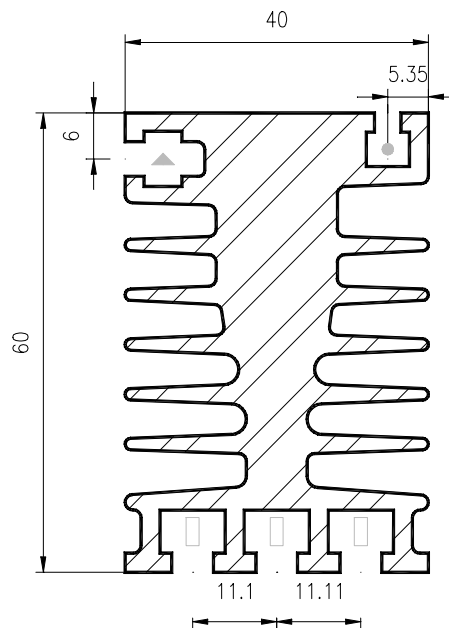

- ▲ Mounting channel for M4 screw
- Mounting channel for M4 screw
- Mounting channel for M5 screw

Approximate scale : 1/1.

Thermal Resistance :

Natural Convection

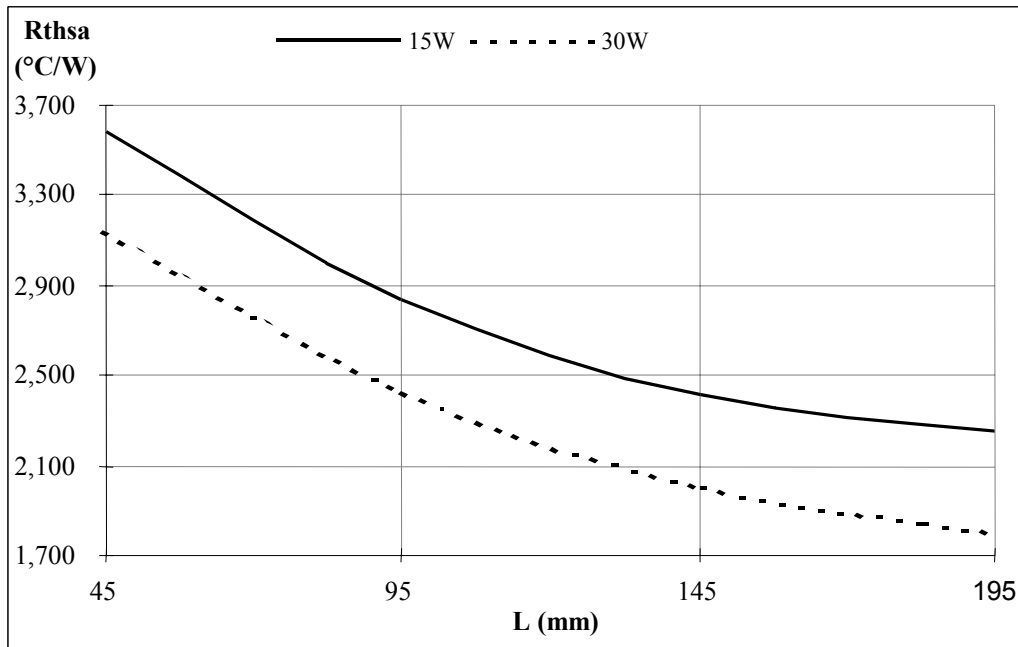

CAUTION :

ARCEL reserves the right to make modifications to its technical data and product specifications at any time without prior notice. Thermal resistances are given as information. Thermal resistance depend on several parameters, thus exact value of thermal resistance can only be determined by direct measurement for the given configuration.

For more information :

ARCEL
2, rue des Aulnes
Z.I. du Tronchon
F-69410 Champagne-au-Mont-d'Or

☎ +33 478 350 221
Fax : +33 478 356 954
Email : info@arcel.fr