

# AR125

- ✓ Heatsink for insulated modules
- ✓ Weight : 15,5 Kg/m
- ✓ Application : natural and air forced cooling
- ✓ Plating : contact us
- ✓ Available length on stock :
  - AR125B : 1500 mm
  - AR125SG : 3100 mm
- ✓ Machining and assemblies on request

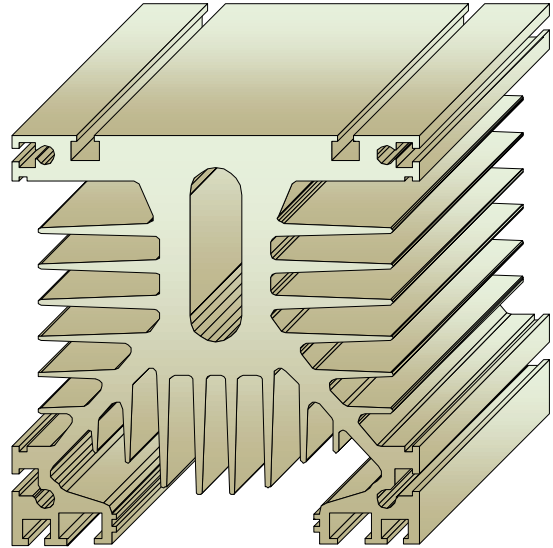

## Dimensions

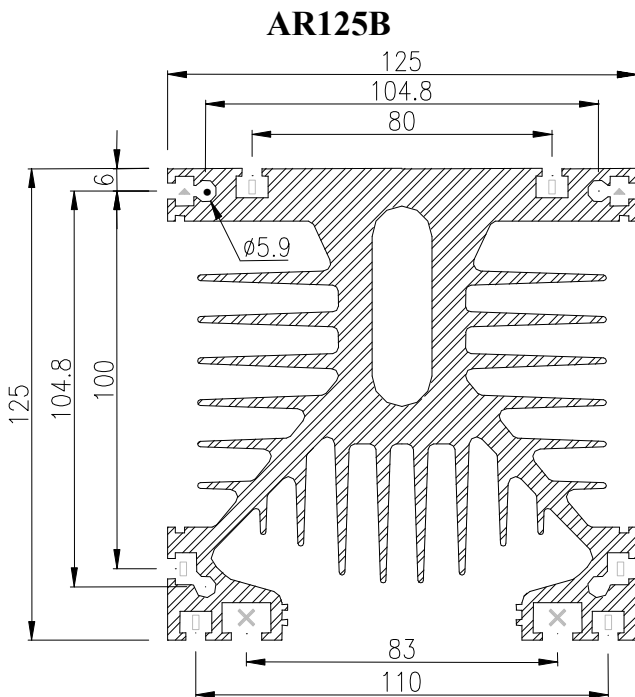

- △ Mounting channel for M4 screw
- Mounting channel for M5 screw
- X Mounting channel for M8 screw
- Mounting channel for M4 insert

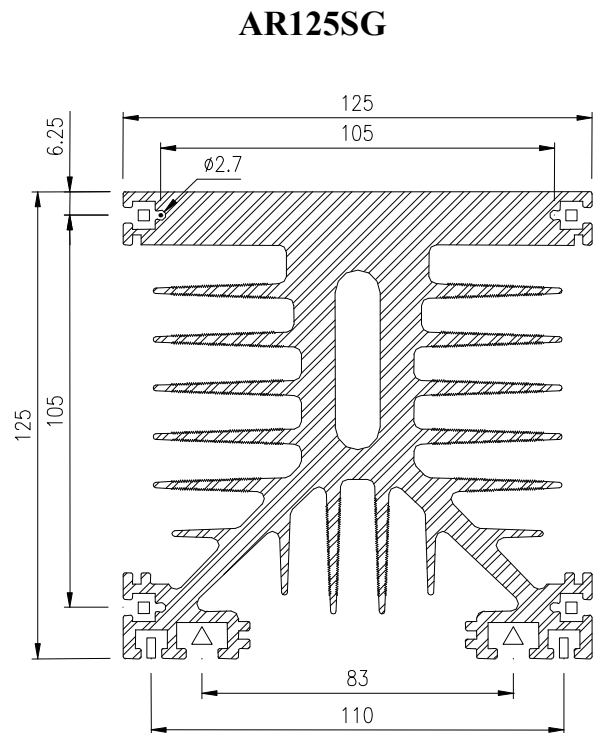

- △ Mounting channel for M8 screw
- Mounting channel for M4 screw
- Mounting channel for M5 screw
- Mounting channel for M3 screw

*Approximate scale : 1/2.*

## Thermal Resistance

### Natural Convection

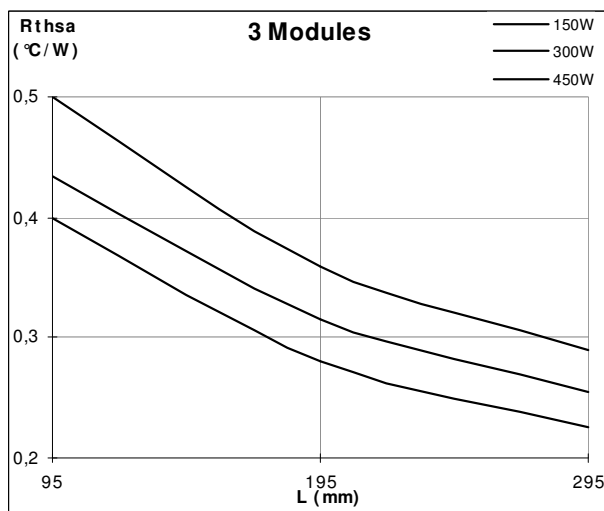
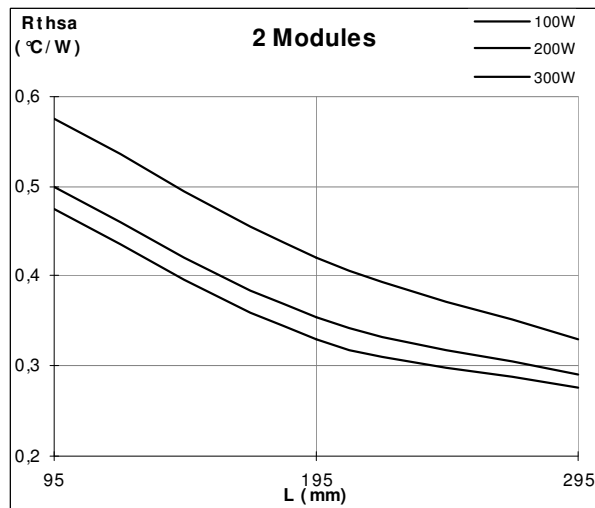
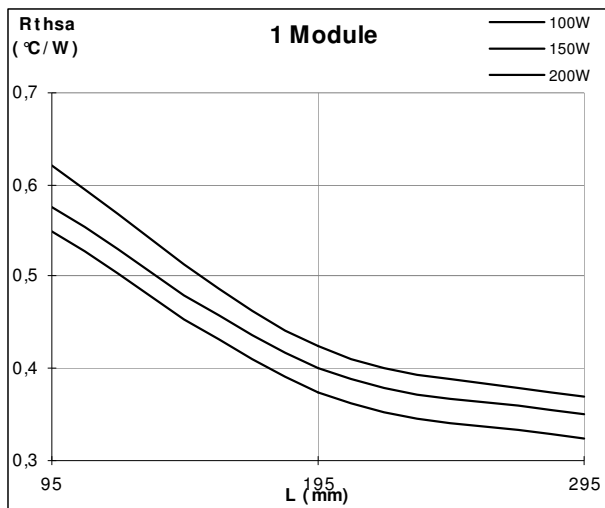

## Forced Air

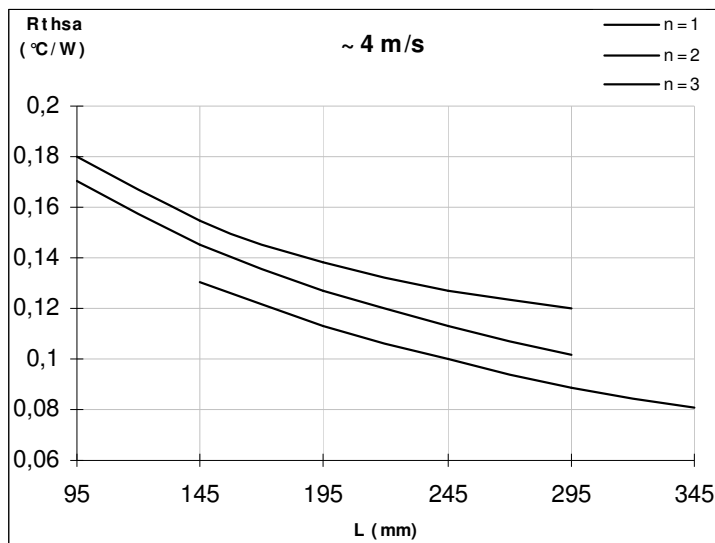

### CAUTION :

ARCEL reserves the right to make modifications to its technical data and product specifications at any time without prior notice. Thermal resistances are given as information. Thermal resistance depend on several parameters, thus exact value of thermal resistance can only be determined by direct measurement for the given configuration.

### For more information :

**ARCEL**  
2, rue des Aulnes  
Z.I. du Tronchon  
F-69410 Champagne-au-Mont-d'Or

☎ +33 478 350 221  
Fax : +33 478 356 954  
Email : [info@arcel.fr](mailto:info@arcel.fr)