

C-SERIES

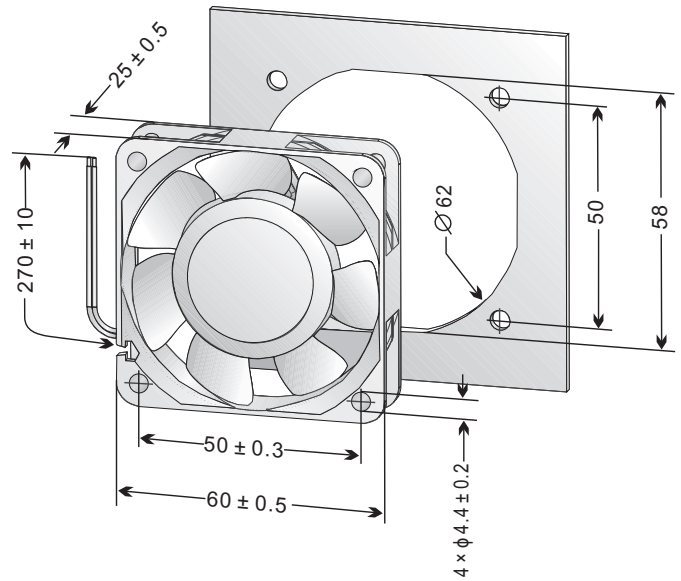

60 x 60 x 25 mm -7

Frame: Thermoplastic PBT (GF 30%), UL94-V0
 Impeller: Thermoplastic PBT (GF 15%), UL94-V0
 Bearing System: Ball Bearing or Sleeve Bearing
 Lead Wire: UL 1007, AWG 24 / 280 mm, Red (+), Black (-)
 Protection: Locked rotor protected for minimum 72 hours



PQ GRAPH (AT RATED VOLTAGE)

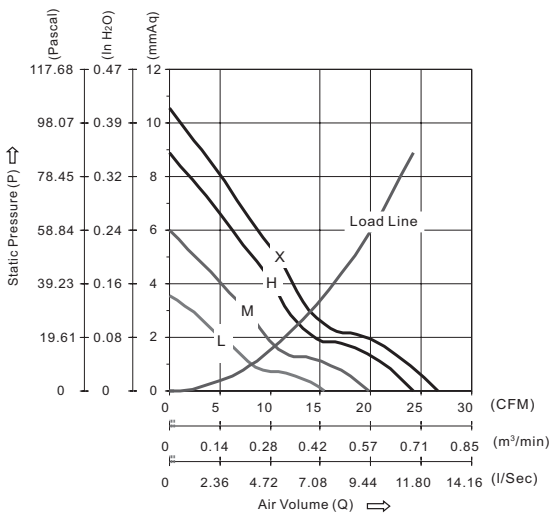

AVAILABLE FUNCTIONS

1a. IR	1b. AS	1c. MS	2a. FG	2b. RD	2c. RD _b	2d. LD	3. SG/PWM
	●		●	●	●		
4. OV	5a. TPWM	5b. RPWM	6. CL	7. CS	8a. VPWM	8b. IPWM	8c. PPWM

Part Number	Voltage (VDC)	Current (Amp.)	Power (Watts)	Speed (RPM)	Air Flow (Q)		Pressure (P)		Noise (dBA)	Unit Weight (Q'TY/CTN)
					(CFM)	(m ³ /min)	(mmAq)	(In H ₂ O)		
C6025X12BPLBx-7	12 (07-14)	0.265	3.18	6000	26.70	0.756	10.56	0.416	41.56	73.5 g (224 pcs)
* C6025H12BPLBx-7		0.240	2.88	5500	24.28	0.688	8.91	0.351	39.31	
C6025M12BPLBx-7		0.155	1.86	4500	19.81	0.561	5.99	0.236	34.13	
C6025L12BPLBx-7		0.090	1.08	3500	15.41	0.436	3.57	0.141	27.86	
C6025X24BPLBx-7	24 (15-27)	0.136	3.26	6000	26.70	0.756	10.56	0.416	41.56	73.5 g (224 pcs)
* C6025H24BPLBx-7		0.125	3.00	5500	24.28	0.688	8.91	0.351	39.31	
C6025M24BPLBx-7		0.071	1.71	4500	19.81	0.561	5.99	0.236	34.13	
C6025L24BPLBx-7		0.043	1.03	3500	15.41	0.436	3.57	0.141	27.86	

* small quantities available ex stock

- All MICRONEL fans listed here refer to double ball bearing types; Sleeve bearing types may consume about 10% more power for the same speed.
- Noise Measurements are taken with background noise of 16.8 dBA.
- Please see «Function Legend» for explanation of each function.
- Specifications are subject to change without notice.