

# IP4282CZ6

ESD protection for high-speed interfaces

Rev. 01 — 30 March 2009

Product data sheet

## HDMI

### 1. Product profile

---

#### 1.1 General description

The IP4282CZ6 is designed to protect high-speed interfaces such as HDMI, DVI and DisplayPort interfaces. The device includes high-level ElectroStatic Discharge (ESD) protection diodes for the TMDS signal lines.

All TMDS intra-pairs are protected by a special diode configuration offering a low line capacitance of only 0.7 pF. These diodes provide protection to downstream components from ESD voltages up to  $\pm 8$  kV contact according to IEC 61000-4-2, level 4.

#### 1.2 Features

- 'Pass-thru' signal line routing
- Pb-free, RoHS compliant and free of Halogen and Antimony (Dark Green compliant)
- All TMDS lines with integrated rail-to-rail clamping diodes for downstream ESD protection of  $\pm 8$  kV according to IEC 61000-4-2, level 4
- Matched 0.5 mm trace spacing
- Line capacitance of only 0.7 pF for each channel
- 2-channel, 6-terminal UTLP
- HDMI 1.3a compliant
- DisplayPort compliant

#### 1.3 Applications

The IP4282CZ6 is designed for HDMI receiver and transmitter port protection:

- TVs, monitors
- DVD recorders and players
- Notebooks, main board graphics cards and ports
- Set-top boxes and game consoles

## 2. Pinning information

Table 1. Pinning

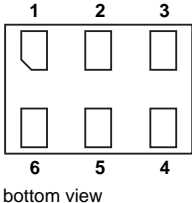
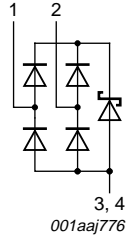
Pin	Symbol	Description	Simplified outline	Graphic symbol
1	TMDS_CH1-	negative channel 1 ESD protection		
2	TMDS_CH1+	positive channel 1 ESD protection		
3	GND	ground		
4	GND	ground		
5	n.c.	not connected		
6	n.c.	not connected		

## 3. Ordering information

Table 2. Ordering information

Type number	Package		Version
	Name	Description	
IP4282CZ6	XSON6	plastic extremely thin small outline package; no leads; 6 terminals; body 1 × 1.45 × 0.5 mm	SOT886

## 4. Limiting values

Table 3. Limiting values

In accordance with the Absolute Maximum Rating System (IEC 60134).

Symbol	Parameter	Conditions	Min	Max	Unit
$V_I$	input voltage		GND – 0.5	+5.5	V
$V_{esd}$	electrostatic discharge voltage	all pins to ground; IEC 61000-4-2, level 4; contact discharge	–8	+8	kV
$T_{stg}$	storage temperature		–55	+125	°C
$T_{amb}$	ambient temperature		–40	+85	°C

## 5. Characteristics

Table 4. Characteristics

Symbol	Parameter	Conditions	Min	Typ	Max	Unit
$V_{BRzd}$	Zener diode breakdown voltage	$I = 1 \text{ mA}$	6	-	9	V
$I_{LRzd}$	Zener diode reverse leakage current	per TMDS channel; $V = 3.0 \text{ V}$	-	-	1	$\mu\text{A}$
$V_F$	forward voltage		-	0.7	-	V
$C_{ch(TMDS)}$	TMDS channel capacitance	$f = 1 \text{ MHz}; V_{bias} = 2.5 \text{ V}$	[1]	-	0.7	pF
$\Delta C_{ch(TMDS)}$	TMDS channel capacitance difference	$f = 1 \text{ MHz}; V_{bias} = 2.5 \text{ V}$	[1]	-	0.05	pF
$C_{ch(mutual)}$	mutual channel capacitance	between signal pin and pin n.c.; $f = 1 \text{ MHz}; V_{bias} = 2.5 \text{ V}$	[1]	-	0.07	pF

**Table 4. Characteristics ...continued**

Symbol	Parameter	Conditions	Min	Typ	Max	Unit
R <sub>dyn</sub>	dynamic resistance	I = 1 A; T <sub>amb</sub> = 25 °C; IEC 61000-4-5/9				
		positive transient	-	2.4	-	Ω
		negative transient	-	1.3	-	Ω
V <sub>CL(ch)trt(pos)</sub>	positive transient channel clamping voltage	V <sub>esd</sub> = 8 kV HBM; T <sub>amb</sub> = 25 °C	[2] -	8	-	V

[1] This parameter is guaranteed by design.  
 [2] Human Body Model according to JESD22-A-J114D.

## 6. Application information

The IP4282CZ6 is designed to provide high-level ESD protection for high-speed serial data buses such as HDMI, DVI, DisplayPort, USB2.0 and other LVDS data lines.

A basic application diagram for the ESD protection of an HDMI interface is shown in [Figure 1](#), and a USB interface in [Figure 2](#).

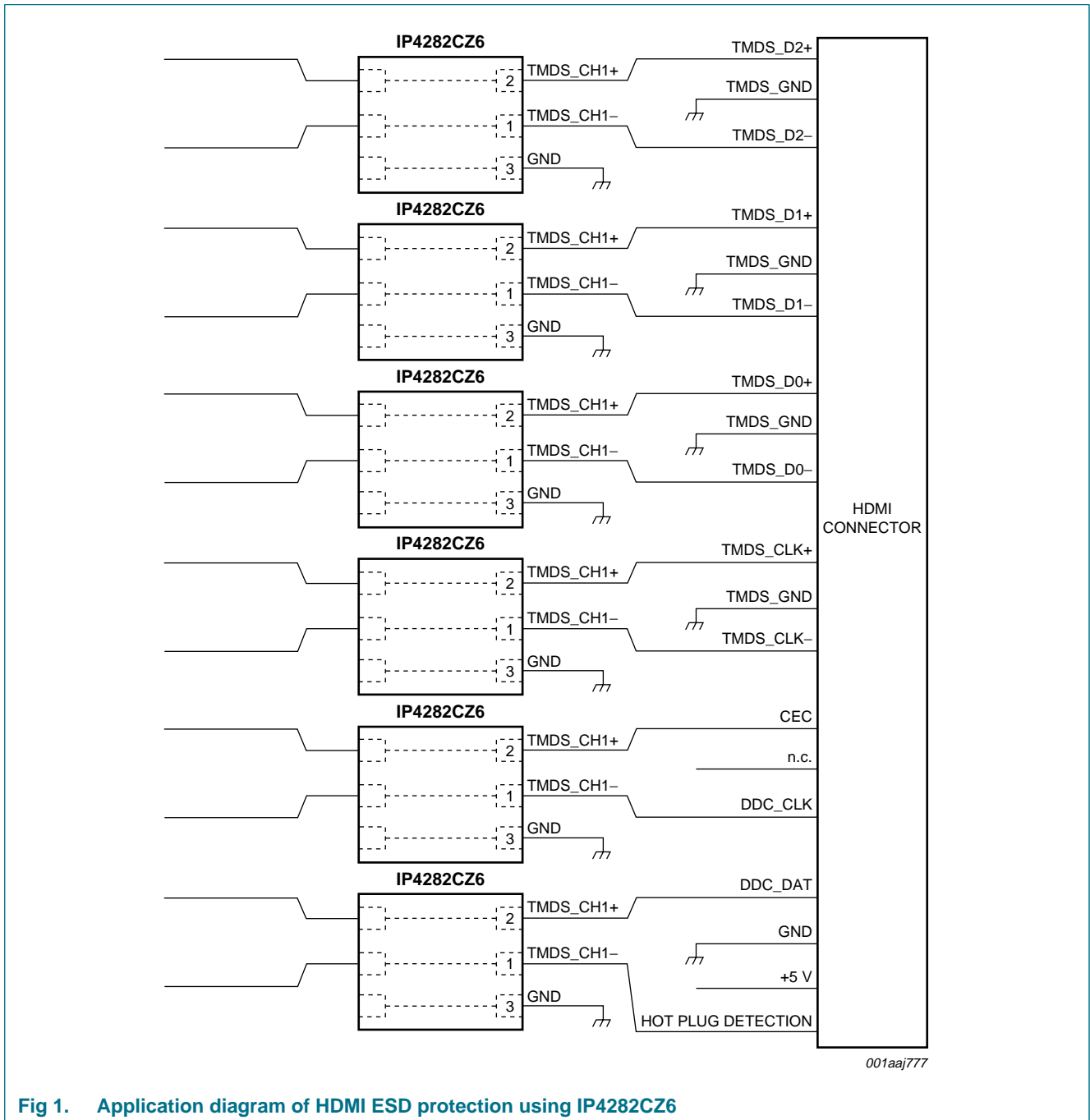
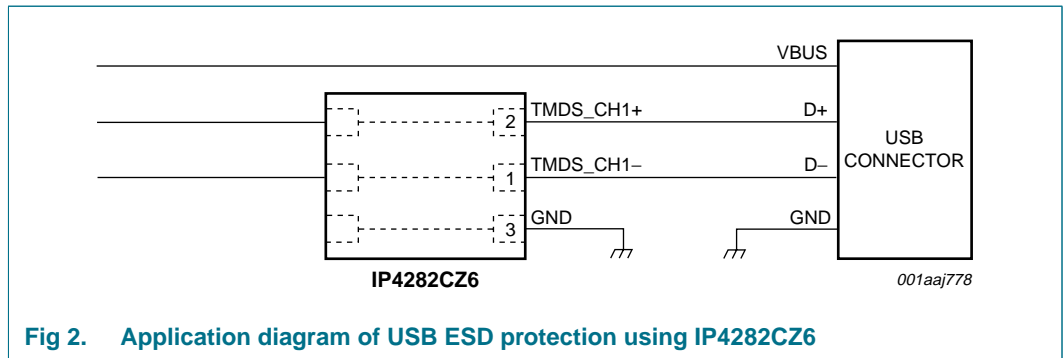

Fig 1. Application diagram of HDMI ESD protection using IP4282CZ6



## 7. Package outline

XSON6: plastic extremely thin small outline package; no leads; 6 terminals; body 1 x 1.45 x 0.5 mm

SOT886

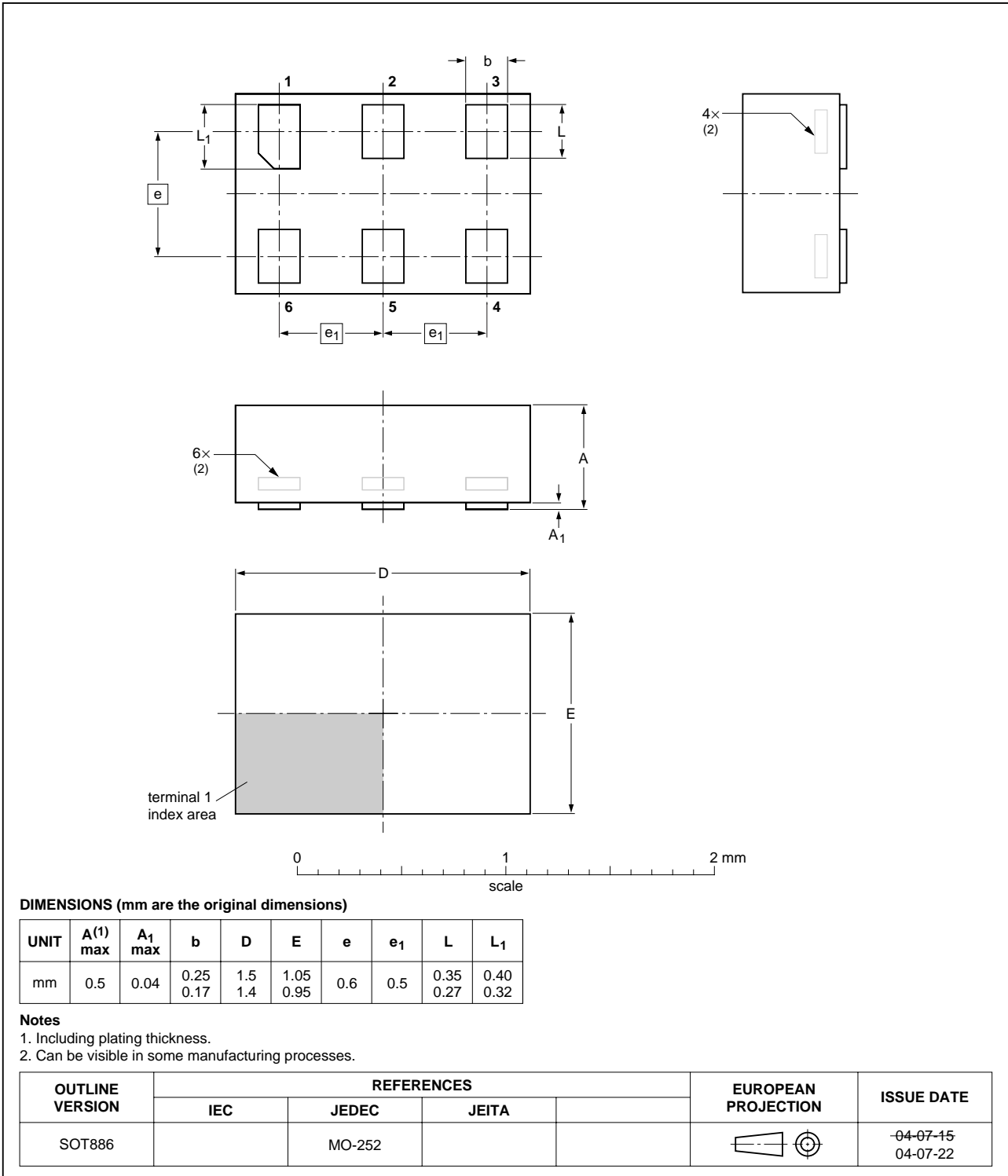

Fig 3. Package outline SOT886 (XSON6)

## 8. Abbreviations

**Table 5. Abbreviations**

Acronym	Description
DVD	Digital Versatile Disc
DVI	Digital Visual Interface
ESD	ElectroStatic Discharge
HBM	Human Body Model
HDMI	High-Definition Multimedia Interface
LVDS	Low-Voltage Differential Signaling
RoHS	Restriction of Hazardous Substances
TMDS	Transition Minimized Differential Signaling
USB	Universal Serial Bus
UTLP	Ultra-Thin Leadless Package

## 9. Revision history

**Table 6. Revision history**

Document ID	Release date	Data sheet status	Change notice	Supersedes
IP4282CZ6_1	20090330	Product data sheet	-	-

## 10. Legal information

### 10.1 Data sheet status

Document status <sup>[1][2]</sup>	Product status <sup>[3]</sup>	Definition
Objective [short] data sheet	Development	This document contains data from the objective specification for product development.
Preliminary [short] data sheet	Qualification	This document contains data from the preliminary specification.
Product [short] data sheet	Production	This document contains the product specification.

[1] Please consult the most recently issued document before initiating or completing a design.

[2] The term 'short data sheet' is explained in section "Definitions".

[3] The product status of device(s) described in this document may have changed since this document was published and may differ in case of multiple devices. The latest product status information is available on the Internet at URL <http://www.nxp.com>.

### 10.2 Definitions

**Draft** — The document is a draft version only. The content is still under internal review and subject to formal approval, which may result in modifications or additions. NXP Semiconductors does not give any representations or warranties as to the accuracy or completeness of information included herein and shall have no liability for the consequences of use of such information.

**Short data sheet** — A short data sheet is an extract from a full data sheet with the same product type number(s) and title. A short data sheet is intended for quick reference only and should not be relied upon to contain detailed and full information. For detailed and full information see the relevant full data sheet, which is available on request via the local NXP Semiconductors sales office. In case of any inconsistency or conflict with the short data sheet, the full data sheet shall prevail.

### 10.3 Disclaimers

**General** — Information in this document is believed to be accurate and reliable. However, NXP Semiconductors does not give any representations or warranties, expressed or implied, as to the accuracy or completeness of such information and shall have no liability for the consequences of use of such information.

**Right to make changes** — NXP Semiconductors reserves the right to make changes to information published in this document, including without limitation specifications and product descriptions, at any time and without notice. This document supersedes and replaces all information supplied prior to the publication hereof.

**Suitability for use** — NXP Semiconductors products are not designed, authorized or warranted to be suitable for use in medical, military, aircraft, space or life support equipment, nor in applications where failure or malfunction of an NXP Semiconductors product can reasonably be expected to result in personal injury, death or severe property or environmental damage. NXP Semiconductors accepts no liability for inclusion and/or use of NXP Semiconductors products in such equipment or applications and therefore such inclusion and/or use is at the customer's own risk.

**Applications** — Applications that are described herein for any of these products are for illustrative purposes only. NXP Semiconductors makes no representation or warranty that such applications will be suitable for the specified use without further testing or modification.

**Limiting values** — Stress above one or more limiting values (as defined in the Absolute Maximum Ratings System of IEC 60134) may cause permanent damage to the device. Limiting values are stress ratings only and operation of the device at these or any other conditions above those given in the Characteristics sections of this document is not implied. Exposure to limiting values for extended periods may affect device reliability.

**Terms and conditions of sale** — NXP Semiconductors products are sold subject to the general terms and conditions of commercial sale, as published at <http://www.nxp.com/profile/terms>, including those pertaining to warranty, intellectual property rights infringement and limitation of liability, unless explicitly otherwise agreed to in writing by NXP Semiconductors. In case of any inconsistency or conflict between information in this document and such terms and conditions, the latter will prevail.

**No offer to sell or license** — Nothing in this document may be interpreted or construed as an offer to sell products that is open for acceptance or the grant, conveyance or implication of any license under any copyrights, patents or other industrial or intellectual property rights.

**Export control** — This document as well as the item(s) described herein may be subject to export control regulations. Export might require a prior authorization from national authorities.

### 10.4 Licenses

#### Purchase of NXP ICs with HDMI technology

Use of an NXP IC with HDMI technology in equipment that complies with the HDMI standard requires a license from HDMI Licensing LLC, 1060 E. Arques Avenue Suite 100, Sunnyvale CA 94085, USA, e-mail: [admin@hdmi.org](mailto:admin@hdmi.org).

### 10.5 Trademarks

Notice: All referenced brands, product names, service names and trademarks are the property of their respective owners.

## 11. Contact information

For more information, please visit: <http://www.nxp.com>

For sales office addresses, please send an email to: [salesaddresses@nxp.com](mailto:salesaddresses@nxp.com)

## 12. Contents

<b>1</b>	<b>Product profile</b> .....	<b>1</b>
1.1	General description .....	1
1.2	Features .....	1
1.3	Applications .....	1
<b>2</b>	<b>Pinning information</b> .....	<b>2</b>
<b>3</b>	<b>Ordering information</b> .....	<b>2</b>
<b>4</b>	<b>Limiting values</b> .....	<b>2</b>
<b>5</b>	<b>Characteristics</b> .....	<b>2</b>
<b>6</b>	<b>Application information</b> .....	<b>4</b>
<b>7</b>	<b>Package outline</b> .....	<b>6</b>
<b>8</b>	<b>Abbreviations</b> .....	<b>7</b>
<b>9</b>	<b>Revision history</b> .....	<b>7</b>
<b>10</b>	<b>Legal information</b> .....	<b>8</b>
10.1	Data sheet status .....	8
10.2	Definitions .....	8
10.3	Disclaimers .....	8
10.4	Licenses .....	8
10.5	Trademarks .....	8
<b>11</b>	<b>Contact information</b> .....	<b>8</b>
<b>12</b>	<b>Contents</b> .....	<b>9</b>

Please be aware that important notices concerning this document and the product(s) described herein, have been included in section 'Legal information'.



© NXP B.V. 2009.

All rights reserved.

For more information, please visit: <http://www.nxp.com>

For sales office addresses, please send an email to: [salesaddresses@nxp.com](mailto:salesaddresses@nxp.com)

Date of release: 30 March 2009

Document identifier: IP4282CZ6\_1