

IP4309CX9

HDMI octal channel low capacitive high-performance ESD protection

Rev. 1 — 10 March 2011

Product data sheet

1. Product profile

1.1 General description

The IP4309CX9 is a 8-channel low capacitance ElectroStatic Discharge (ESD) protection device, providing protection to downstream components from ESD voltages up to ± 15 kV contact discharge and higher than ± 15 kV air discharge, far exceeding IEC 61000-4-2, level 4.

The device is optimized for the protection of high-speed interfaces such as High-Definition Multimedia Interface (HDMI), Digital Video Interface (DVI) and other interfaces requiring very low capacitance ESD protection. In order to prevent any current backdrive into the adjacent channel, all eight ESD protection channels are electrically separated and share only the same ground connections.

The IP4309CX9 is fabricated using monolithic silicon technology in a single Wafer Level Chip-Size Package (WLCSP). These features make IP4309CX9 ideal for use in applications requiring component miniaturization, such as mobile phone handsets.

1.2 Features and benefits

- Pb-free, Restriction of Hazardous Substances (RoHS) compliant and free of halogen and antimony (dark green compliant)
- 8 ultra low input capacitance rail-to-rail ESD protection diodes with $C_{I/O} = 1.3$ pF
- $R_{dyn} = 0.45 \Omega$
- Downstream ESD protection up to ± 15 kV (contact), exceeding IEC 61000-4-2, level 4
- 3×3 pin WLCSP with 0.4 mm pitch

1.3 Applications

- High-speed interface ESD protection such as HDMI, DVI and USB etc.
- Interfaces with special requirements on low capacitive ESD protection
- Interfaces requiring separation of the positive clamping voltage / current path



2. Pinning information

2.1 Pinning

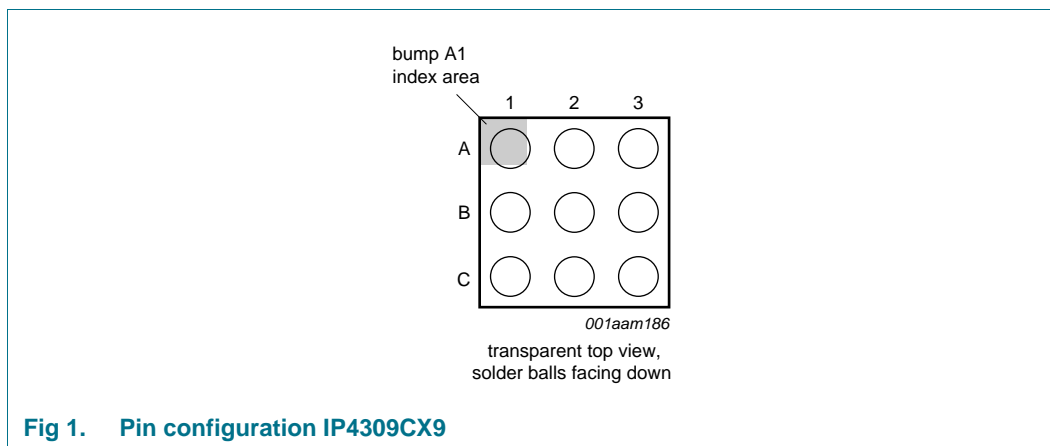

Fig 1. Pin configuration IP4309CX9

2.2 Pin description

Table 1. Pinning

Pin	Description
A1	ESD protection
A2	ESD protection
A3	ESD protection
B1	ESD protection
B2	ground
B3	ESD protection
C1	ESD protection
C2	ESD protection
C3	ESD protection

3. Ordering information

Table 2. Ordering information

Type number	Package		Version
	Name	Description	
IP4309CX9	WLCSP9	wafer level chip-size package; 9 bumps; 1.16 × 1.16 × 0.61 mm	IP4309CX9

4. Functional diagram

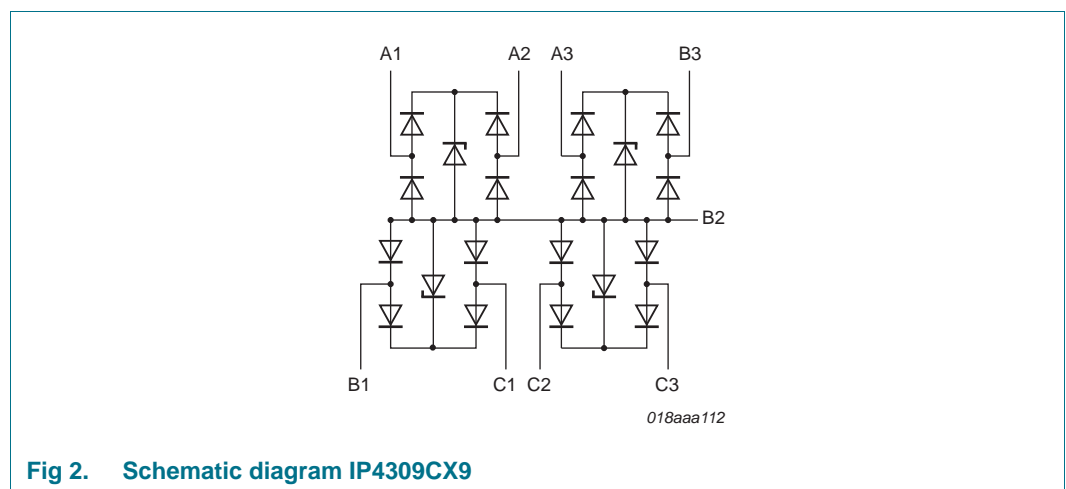

5. Limiting values

Table 3. Limiting values

In accordance with the Absolute Maximum Rating System (IEC 60134).

Symbol	Parameter	Conditions	Min	Max	Unit	
V_I	input voltage	at I/O pins	-0.5	+5.5	V	
V_{ESD}	electrostatic discharge voltage		[1]			
		contact discharge	[2] -	±15	kV	
		air discharge	[2] -	±15	kV	
		IEC 61000-4-2, level 4				
		contact discharge	-	±8	kV	
	air discharge	-	±15	kV		
T_{stg}	storage temperature		-55	+150	°C	
$T_{reflow(peak)}$	peak reflow temperature	$t_p \leq 10$ s	-	260	°C	
T_{amb}	ambient temperature		-30	+85	°C	

[1] All pins to ground.

[2] IP4309CX9 is qualified to 1000 contact discharges of ±15 kV using the IEC 61000-4-2 model, far exceeding the specified IEC 61000-4-2, level 4 (8 kV contact discharge).

6. Characteristics

Table 4. Characteristics

$T_{amb} = 25$ °C unless otherwise specified.

Symbol	Parameter	Conditions	Min	Typ	Max	Unit
$C_{(I/O-GND)}$	input/output to ground capacitance	$V_I = 0.5$ V; $f = 1$ MHz	[1][2] 1.0	1.3	1.5	pF
I_{LR}	reverse leakage current	$V_I = 3$ V	[2] -	-	50	nA
V_{BRzd}	Zener diode breakdown voltage	$I_{test} = 1$ mA	6	-	11	V
V_F	forward voltage		-	0.7	-	V
R_{dyn}	dynamic resistance	$I = 1$ A	[3]			
		positive transient	-	0.45	-	Ω
		negative transient	-	0.5	-	Ω

[1] Guaranteed by design.

[2] Pins A1, A2, A3, B1, B3, C1 and C2 to ground.

[3] According to IEC 61000-4-5 and IEC 61000-4-9.

7. Application information

7.1 Insertion loss

The IP4309CX9 is mainly designed as an ESD protection device for high-speed interfaces such as HDMI, DVI and USB data lines etc.

The insertion loss in a 50 Ω NetWork Analyzer (NWA) of two channels of IP4309CX9 is depicted in Figure 4. The other channels behave similar as all channels contain an identical electrical circuitry.

The insertion loss measurement configuration of a typical 50 Ω NWA system for evaluation of the IP4309CX9 is shown in Figure 3. It was measured using a test Printed-Circuit Board (PCB) utilizing laser-drilled micro-via holes that connect the PCB ground plane to the ground pins.

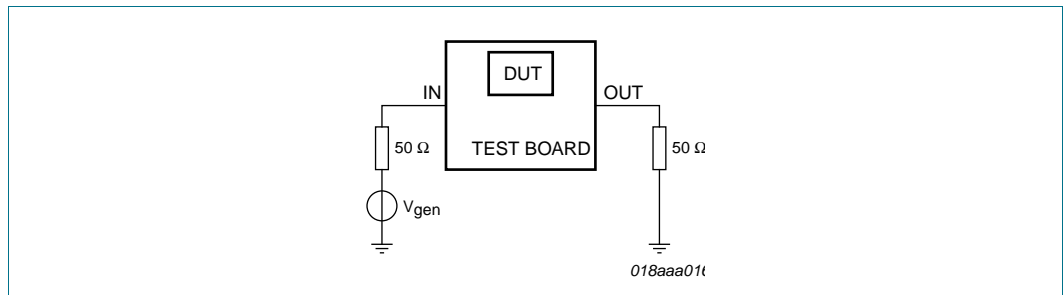

Fig 3. Frequency response setup

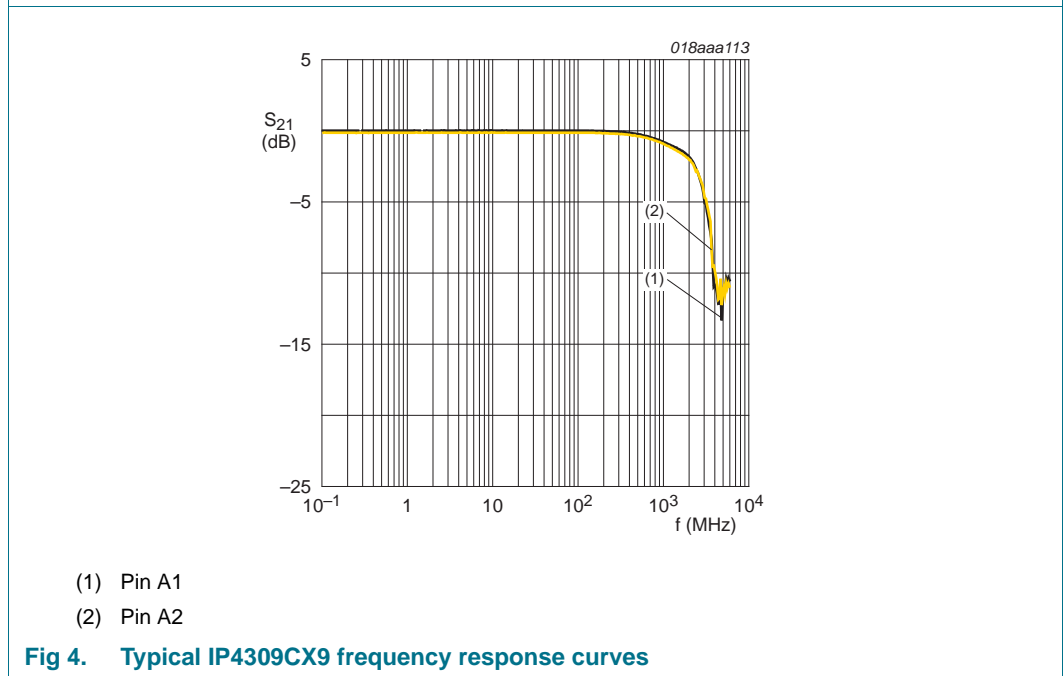

Fig 4. Typical IP4309CX9 frequency response curves

7.2 Crosstalk

The setup for crosstalk measurements in a 50 Ω NWA system for several pin combinations reflecting the various possible physical distances is shown in [Figure 5](#).

The crosstalk measurement results are depicted in [Figure 6](#). Other combinations behave similar, depending on the distance between the pins.

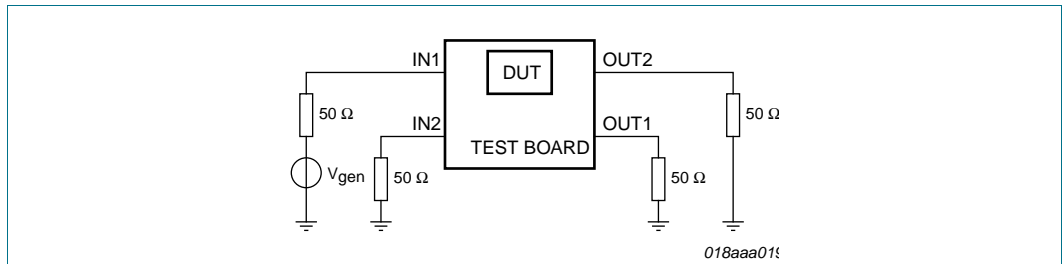

Fig 5. Crosstalk measurement configuration

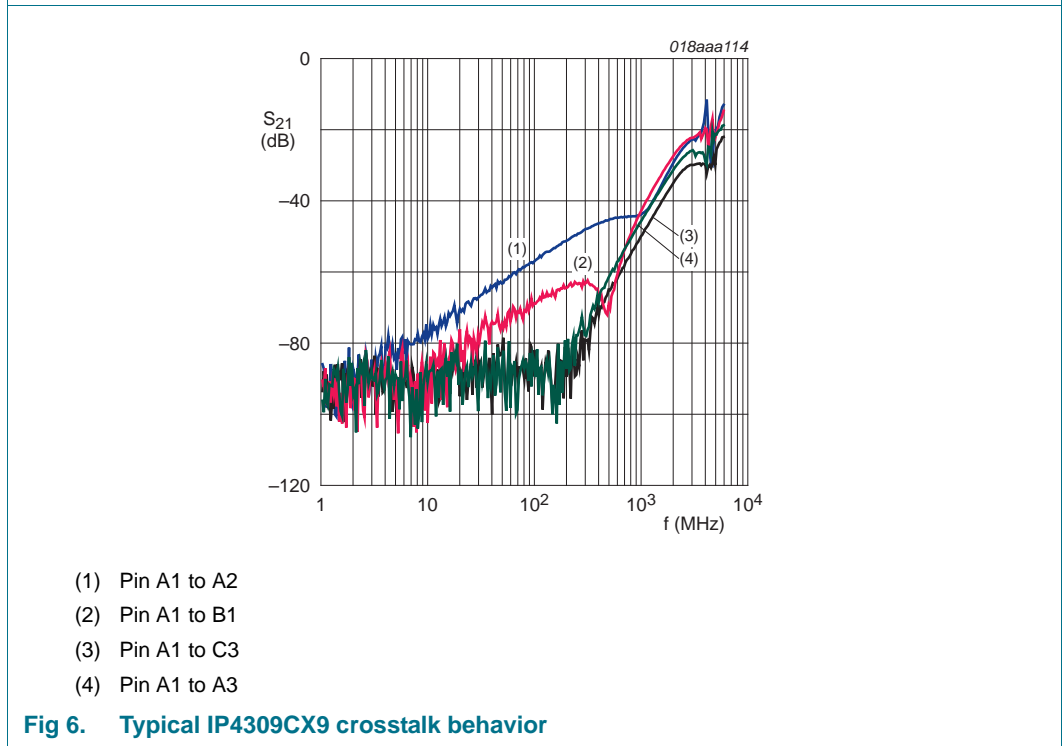

Fig 6. Typical IP4309CX9 crosstalk behavior

8. Package outline

WLCSP9: wafer level chip-size package; 9 bumps (3 x 3)

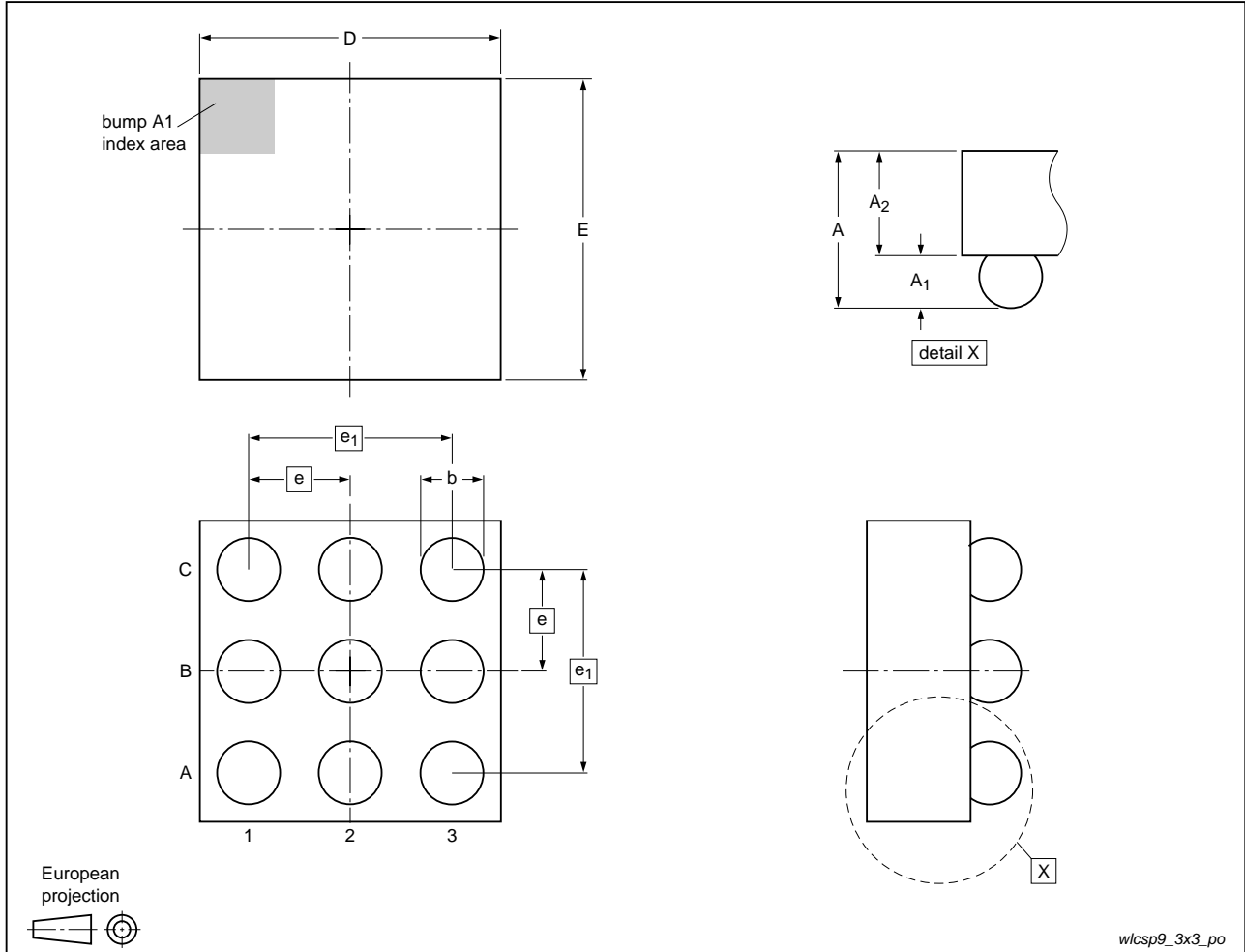

Fig 7. Package outline WLCSP9 (IP4309CX9)

Table 5. Package outline dimensions

Symbol	Min	Typ	Max	Unit
A	0.57	0.61	0.65	mm
A ₁	0.18	0.20	0.22	mm
A ₂	0.59	0.61	0.63	mm
b	0.21	0.26	0.31	mm
D	1.11	1.16	1.21	mm
E	1.11	1.16	1.21	mm
e	-	0.40	-	mm
e ₁	-	0.8	-	mm

9. Packing information

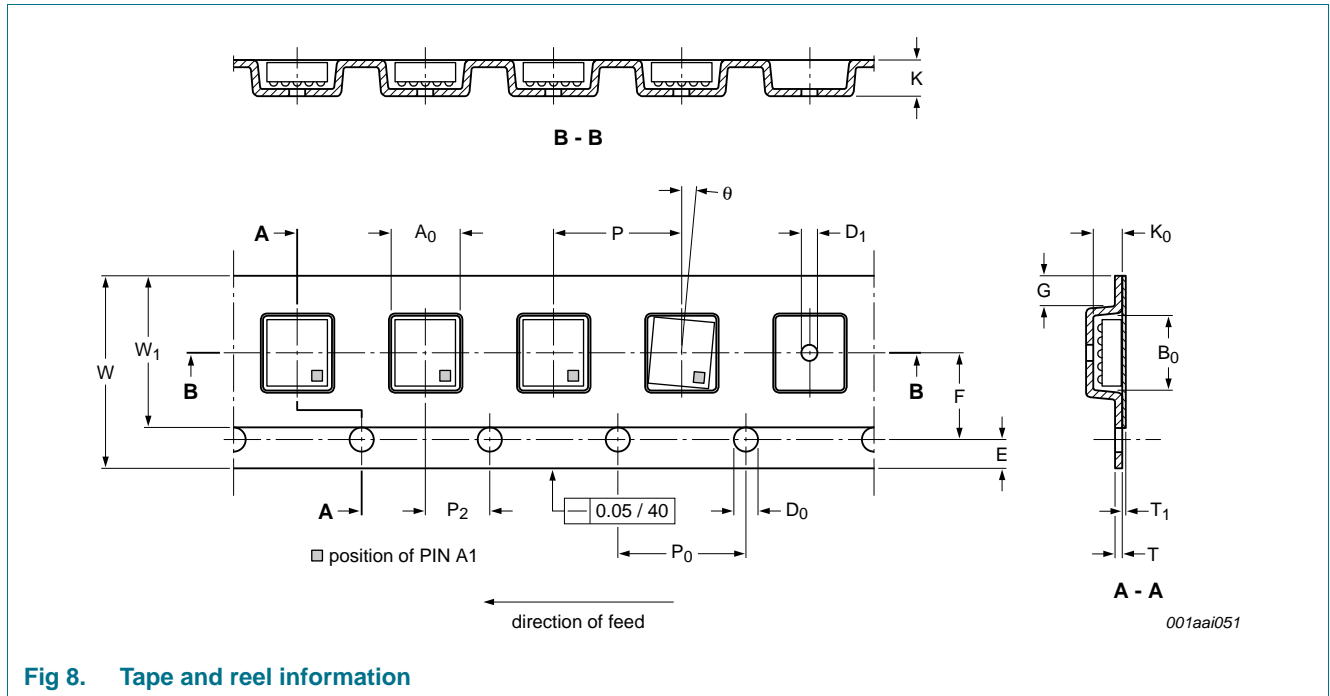

Table 6. Tape dimensions

Description	Item	Symbol	Specification (mm)	
			Dimension	Tolerance
Overall dimensions	tape width	W	8.00	±0.1
	thickness	K	1.20	max
	distance	G	0.75	min
Sprocket holes ^[1]	diameter	D ₀	1.50	+0.1
	distance	E	1.75	±0.1
	pitch	P ₀	4.00	±0.1
Distance between center lines	length direction	P ₂	2.00	±0.05
	width direction	F	3.50	±0.05
Compartments	length	A ₀	1.32	±0.05
	width	B ₀	1.28	±0.05
	depth	K ₀	0.80	±0.05
	hole diameter	D ₁	0.50	+0.1
	pitch	P	4.00	±0.1

Table 6. Tape dimensions ...continued

Description	Item	Symbol	Specification (mm)	
			Dimension	Tolerance
Device	rotation	θ	20°	max
Carrier tape antistatic ^[2]	film thickness	T	0.25	±0.07
Cover tape ^[3]	width	W_1	5.75	max
	film thickness	T_1	0.1	max
Bending radius	in winding direction	R	30	min

[1] Cumulated pitch error: ±0.2 mm per 10 pitches.

[2] Carbon-loaded polystyrene 100 % recyclable.

[3] The cover tape shall not overlap the sprocket holes.

10. Design and assembly recommendations

10.1 PCB design guidelines

It is recommended, for optimum performance, to use a Non-Solder Mask Defined (NSMD), also known as a copper-defined design, incorporating laser-drilled micro-vias connecting the ground pads to a buried ground-plane layer. This results in the lowest possible ground inductance and provides the best high frequency and ESD performance. Refer to [Table 7](#) for the recommended PCB design parameters.

Table 7. Recommended PCB design parameters

Parameter	Value or specification
PCB pad diameter	250 μm
Micro-via diameter	100 μm (0.004 inch)
Solder mask aperture diameter	325 μm
Copper thickness	20 μm to 40 μm
Copper finish	AuNi
PCB material	FR4

10.2 PCB assembly guidelines for Pb-free soldering

Table 8. Assembly recommendations

Parameter	Value or specification
Solder screen aperture diameter	325 μm
Solder screen thickness	100 μm (0.004 inch)
Solder paste: Pb-free	SnAg (3 % to 4 %); Cu (0.5 % to 0.9 %)
Solder to flux ratio	50 : 50
Solder reflow profile	see Figure 9

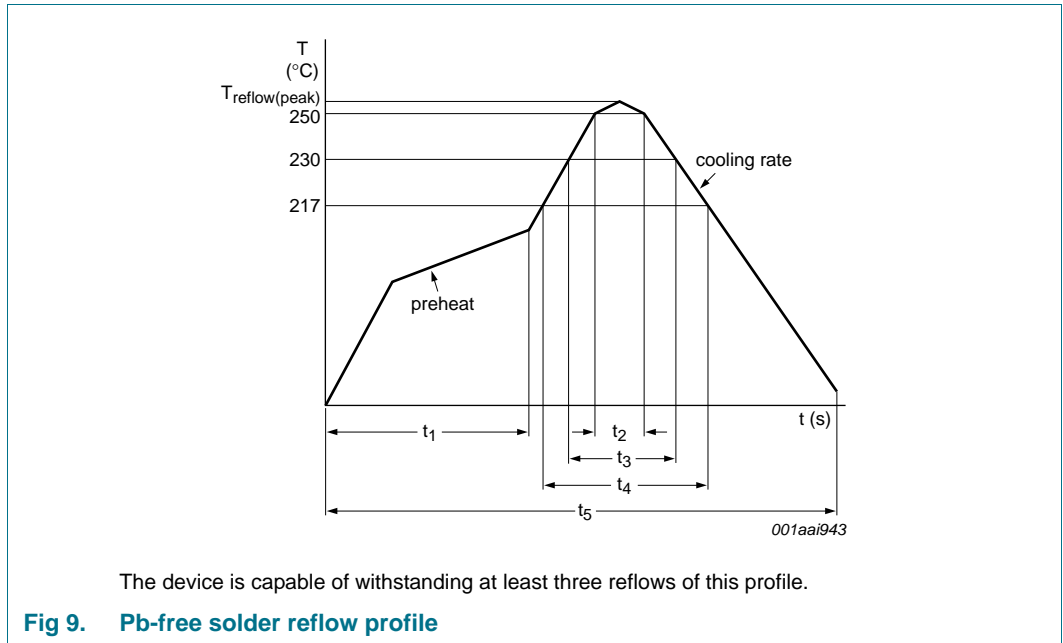

Table 9. Characteristics

Symbol	Parameter	Conditions	Min	Typ	Max	Unit
$T_{\text{reflow(peak)}}$	peak reflow temperature		230	-	260	°C
t_1	time 1	soak time	60	-	180	s
t_2	time 2	time during $T \geq 250 \text{ }^\circ\text{C}$	-	-	30	s
t_3	time 3	time during $T \geq 230 \text{ }^\circ\text{C}$	10	-	50	s
t_4	time 4	time during $T > 217 \text{ }^\circ\text{C}$	30	-	150	s
t_5	time 5		-	-	540	s
dT/dt	rate of change of temperature	cooling rate	-	-	-6	°C/s
		preheat	2.5	-	4.0	°C/s

11. Revision history

Table 10. Revision history

Document ID	Release date	Data sheet status	Change notice	Supersedes
IP4309CX9 v.1	20110310	Product data sheet	-	-

12. Legal information

12.1 Data sheet status

Document status ^{[1][2]}	Product status ^[3]	Definition
Objective [short] data sheet	Development	This document contains data from the objective specification for product development.
Preliminary [short] data sheet	Qualification	This document contains data from the preliminary specification.
Product [short] data sheet	Production	This document contains the product specification.

[1] Please consult the most recently issued document before initiating or completing a design.

[2] The term 'short data sheet' is explained in section "Definitions".

[3] The product status of device(s) described in this document may have changed since this document was published and may differ in case of multiple devices. The latest product status information is available on the Internet at URL <http://www.nxp.com>.

12.2 Definitions

Draft — The document is a draft version only. The content is still under internal review and subject to formal approval, which may result in modifications or additions. NXP Semiconductors does not give any representations or warranties as to the accuracy or completeness of information included herein and shall have no liability for the consequences of use of such information.

Short data sheet — A short data sheet is an extract from a full data sheet with the same product type number(s) and title. A short data sheet is intended for quick reference only and should not be relied upon to contain detailed and full information. For detailed and full information see the relevant full data sheet, which is available on request via the local NXP Semiconductors sales office. In case of any inconsistency or conflict with the short data sheet, the full data sheet shall prevail.

Product specification — The information and data provided in a Product data sheet shall define the specification of the product as agreed between NXP Semiconductors and its customer, unless NXP Semiconductors and customer have explicitly agreed otherwise in writing. In no event however, shall an agreement be valid in which the NXP Semiconductors product is deemed to offer functions and qualities beyond those described in the Product data sheet.

12.3 Disclaimers

Limited warranty and liability — Information in this document is believed to be accurate and reliable. However, NXP Semiconductors does not give any representations or warranties, expressed or implied, as to the accuracy or completeness of such information and shall have no liability for the consequences of use of such information.

In no event shall NXP Semiconductors be liable for any indirect, incidental, punitive, special or consequential damages (including - without limitation - lost profits, lost savings, business interruption, costs related to the removal or replacement of any products or rework charges) whether or not such damages are based on tort (including negligence), warranty, breach of contract or any other legal theory.

Notwithstanding any damages that customer might incur for any reason whatsoever, NXP Semiconductors' aggregate and cumulative liability towards customer for the products described herein shall be limited in accordance with the *Terms and conditions of commercial sale* of NXP Semiconductors.

Right to make changes — NXP Semiconductors reserves the right to make changes to information published in this document, including without limitation specifications and product descriptions, at any time and without notice. This document supersedes and replaces all information supplied prior to the publication hereof.

Suitability for use — NXP Semiconductors products are not designed, authorized or warranted to be suitable for use in life support, life-critical or safety-critical systems or equipment, nor in applications where failure or

malfunction of an NXP Semiconductors product can reasonably be expected to result in personal injury, death or severe property or environmental damage. NXP Semiconductors accepts no liability for inclusion and/or use of NXP Semiconductors products in such equipment or applications and therefore such inclusion and/or use is at the customer's own risk.

Applications — Applications that are described herein for any of these products are for illustrative purposes only. NXP Semiconductors makes no representation or warranty that such applications will be suitable for the specified use without further testing or modification.

Customers are responsible for the design and operation of their applications and products using NXP Semiconductors products, and NXP Semiconductors accepts no liability for any assistance with applications or customer product design. It is customer's sole responsibility to determine whether the NXP Semiconductors product is suitable and fit for the customer's applications and products planned, as well as for the planned application and use of customer's third party customer(s). Customers should provide appropriate design and operating safeguards to minimize the risks associated with their applications and products.

NXP Semiconductors does not accept any liability related to any default, damage, costs or problem which is based on any weakness or default in the customer's applications or products, or the application or use by customer's third party customer(s). Customer is responsible for doing all necessary testing for the customer's applications and products using NXP Semiconductors products in order to avoid a default of the applications and the products or of the application or use by customer's third party customer(s). NXP does not accept any liability in this respect.

Limiting values — Stress above one or more limiting values (as defined in the Absolute Maximum Ratings System of IEC 60134) will cause permanent damage to the device. Limiting values are stress ratings only and (proper) operation of the device at these or any other conditions above those given in the Recommended operating conditions section (if present) or the Characteristics sections of this document is not warranted. Constant or repeated exposure to limiting values will permanently and irreversibly affect the quality and reliability of the device.

Terms and conditions of commercial sale — NXP Semiconductors products are sold subject to the general terms and conditions of commercial sale, as published at <http://www.nxp.com/profile/terms>, unless otherwise agreed in a valid written individual agreement. In case an individual agreement is concluded only the terms and conditions of the respective agreement shall apply. NXP Semiconductors hereby expressly objects to applying the customer's general terms and conditions with regard to the purchase of NXP Semiconductors products by customer.

No offer to sell or license — Nothing in this document may be interpreted or construed as an offer to sell products that is open for acceptance or the grant, conveyance or implication of any license under any copyrights, patents or other industrial or intellectual property rights.

Export control — This document as well as the item(s) described herein may be subject to export control regulations. Export might require a prior authorization from national authorities.

Non-automotive qualified products — Unless this data sheet expressly states that this specific NXP Semiconductors product is automotive qualified, the product is not suitable for automotive use. It is neither qualified nor tested in accordance with automotive testing or application requirements. NXP Semiconductors accepts no liability for inclusion and/or use of non-automotive qualified products in automotive equipment or applications.

In the event that customer uses the product for design-in and use in automotive applications to automotive specifications and standards, customer (a) shall use the product without NXP Semiconductors' warranty of the product for such automotive applications, use and specifications, and (b) whenever customer uses the product for automotive applications beyond

NXP Semiconductors' specifications such use shall be solely at customer's own risk, and (c) customer fully indemnifies NXP Semiconductors for any liability, damages or failed product claims resulting from customer design and use of the product for automotive applications beyond NXP Semiconductors' standard warranty and NXP Semiconductors' product specifications.

12.4 Trademarks

Notice: All referenced brands, product names, service names and trademarks are the property of their respective owners.

13. Contact information

For more information, please visit: <http://www.nxp.com>

For sales office addresses, please send an email to: salesaddresses@nxp.com

14. Contents

1	Product profile	1
1.1	General description	1
1.2	Features and benefits	1
1.3	Applications	1
2	Pinning information	2
2.1	Pinning	2
2.2	Pin description	2
3	Ordering information	3
4	Functional diagram	3
5	Limiting values	4
6	Characteristics	4
7	Application information	5
7.1	Insertion loss	5
7.2	Crosstalk	6
8	Package outline	7
9	Packing information	8
10	Design and assembly recommendations	9
10.1	PCB design guidelines	9
10.2	PCB assembly guidelines for Pb-free soldering	9
11	Revision history	11
12	Legal information	12
12.1	Data sheet status	12
12.2	Definitions	12
12.3	Disclaimers	12
12.4	Trademarks	13
13	Contact information	13
14	Contents	14

Please be aware that important notices concerning this document and the product(s) described herein, have been included in section 'Legal information'.

© NXP B.V. 2011.

All rights reserved.

For more information, please visit: <http://www.nxp.com>

For sales office addresses, please send an email to: salesaddresses@nxp.com

Date of release: 10 March 2011

Document identifier: IP4309CX9