

#### Introduction

The LM197-240UW04 is a 24" sunlight readable LCD module with 1920 x 1200 resolution. The module consists of an AUO M240UW04, V0 TFT color LCD glass panel and a Landmark VHB (very high brightness) backlight with a BI528A inverter in a package that has the same foot print and uses the same mounting holes as the original AUO LCD.

With the BI528A inverter setting at full brightness, the LM197-240UW04 module delivers 1,300 Cd/m<sup>2</sup> (nits) of LCD screen luminance. At this level, the display is highly readable under bright ambient lighting including direct outdoor sunlight. The LCD screen luminance can be adjusted down to 15 Cd/m<sup>2</sup> for night viewing.

#### Characteristics (Note 1, 2)

Parameters	Typical Value	Units	Conditions
LCD Screen Luminance	1,300	Cd/m <sup>2</sup>	LCD displaying the brightest white
Luminance Uniformity	20% or better		Note 3
Backlight Power Consumption at max. Screen Luminance	78	Watts	Excluding inverter losses
Screen Luminance Dimming Ratio	150:1		With LMT BI528A inverter
Typical LCD Contrast Ratio	900:1		White vs. Black (measured in the dark along the normal direction)
Typical Viewing Angles			
3:00 direction	80	Degrees	Contrast ratio ≥ 10
9:00 direction	80	Degrees	Contrast ratio ≥ 10
6:00 direction	80	Degrees	Contrast ratio ≥ 10
12:00 direction	80	Degrees	Contrast ratio ≥ 10
LCD Screen Chromaticity (x, y)			
White	(0.320, 0.351)		Measured at the normal direction
Red	(0.643, 0.346)		Measured at the normal direction
Green	(0.271, 0.609)		Measured at the normal direction
Blue	(0.140, 0.072)		Measured at the normal direction
Response Speed			
Rise Time (TR)	3.4	msec	Black to White, 10% - 90% transition
Fall Time (TF)	1.8	msec	White to Black, 90% - 10% transition
LCD Module Weight	3,100	Grams	

Note 1: Please refer to AUO M240UW04, V0 LCD Specification for detailed electrical specifications and general precautions.

Note 2: All data is measured at 25<sup>o</sup> C ± 2<sup>o</sup> C ambient temperature.

Note 3: Uniformity = (L<sub>max</sub> - L<sub>min</sub>) / (L<sub>max</sub> + L<sub>min</sub>) where L<sub>max</sub> (L<sub>min</sub>) is the maximum (minimum) luminance measured using a 10 mm diameter meter aperture over the LCD active area, except for the last 10 mm area from the edges.

## LCD Module Optical Performances

### Luminance & Contrast Ratio

The typical LM197-240UW04 LCD module screen luminance and contrast ratio are shown in the figures below. Since this module is a normally “white” display, the screen luminance is measured at maximum backlight brightness when the LCD is in the “Off” state (i.e. the pixels are not energized). This is the “white” state that provides the maximum luminance. The “white” color displayed on the screen when the video signal is applied may have a lower luminance due to the improper settings of the graphics card and/or the LCD controller. When the LCD is properly driven, the measured luminance of the brightest “White” should be within 10% from the specified value.

**LM197-240UW04 LCD Screen Luminance**  
Angular Distribution

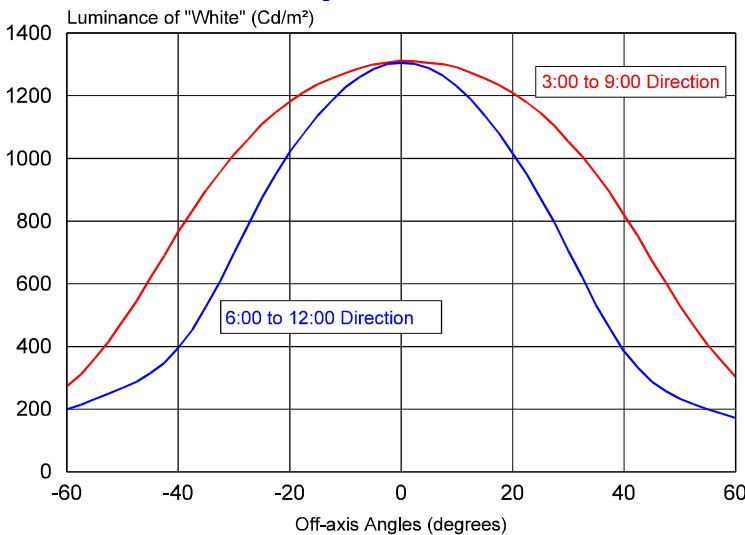

At the optimal viewing directions, the LM197-240UW04 LCD module has a contrast ratio (CR) exceeding 900:1. This is the inherent CR, which is the luminance ratio between the “White” and the “Black” colors measured in a dark room. Under ambient lighting, particularly in bright outdoor environments, the CR value of the display drops significantly due to reflection and glare caused by the strong ambient illumination. For more details, please refer to Landmark Technotes TK1199 and TK0101.

### Chromaticity

The LM197-240UW04 is an LCD module that has a very wide viewing angle with very small color shift.

The figures on the next page present the chromaticity (x, y) data of the R, G, B primary colors displayed on the screen.

**LM197-240UW04 LCD Contrast Ratio**  
Angular Distribution

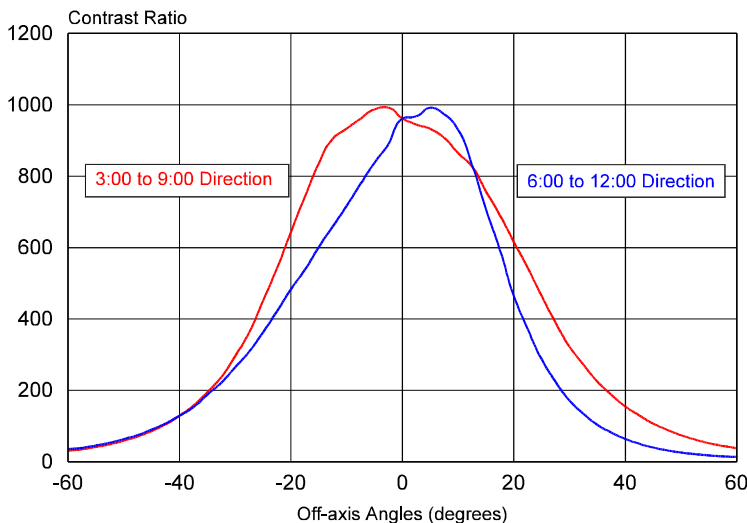

From the figures, it is obvious that the chromaticity values of the R, G, B primary colors do not change much along the 3:00 to 9:00 (horizontal) directions. Along the 6:00 to 12:00 (vertical) directions, the changes are quite small up to 45° off-axis viewing angles.

For off-axis viewing angles beyond 45° along the 6:00 direction, there is a significant color shift toward white. Combined with the drop in screen luminance, the image on the screen appears dark.

LM197-240UW04 Color Shift along the 3:00 - 9:00 Directions  
(Positive Angles are along the 3:00 Direction)

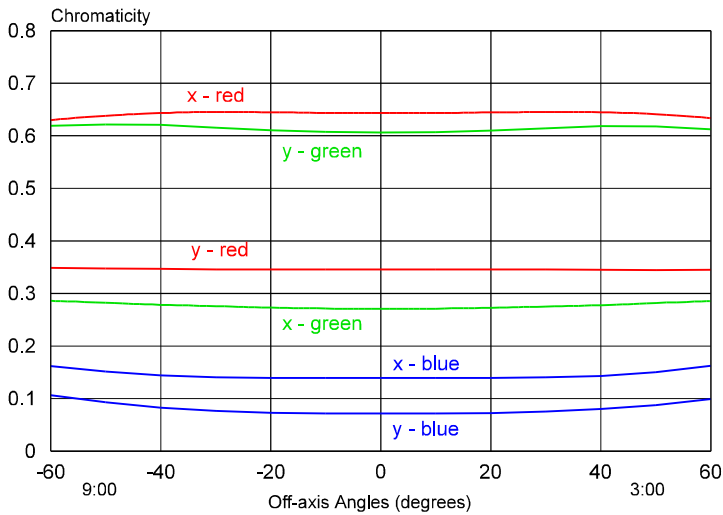

LM197-240UW04 Color Shift along the 6:00 - 12:00 Directions  
(Positive Angles are along the 6:00 Direction)

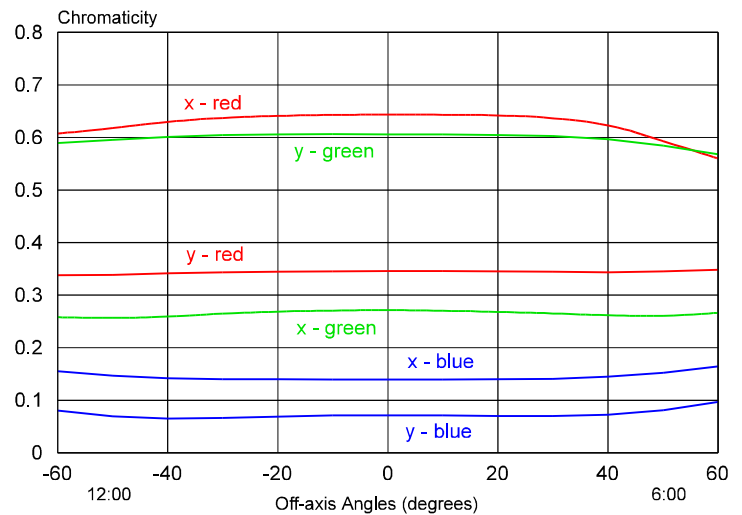

### The LM197-240UW04 VHB Backlight

The LM197-240UW04 LCD module has a VHB backlight with 16 cold cathode fluorescent lamps (CCFLs). The lamps are electrically connected into two groups. Each group has 8 lamps connected in parallel as shown in the following figure. The lamps are wired to two JST 4-pin connectors. The other sides of the lamps are tied together to a lamp common wired to a JST 2-pin connector for redundant connections.

The LM197-240UW04 VHB backlight has a total of 4 JST 4-pin connectors for 16 lamps and 2 JST 2-pin connectors for the 2 lamp commons. The part numbers of the connectors and their mating connectors are listed in the figure below.

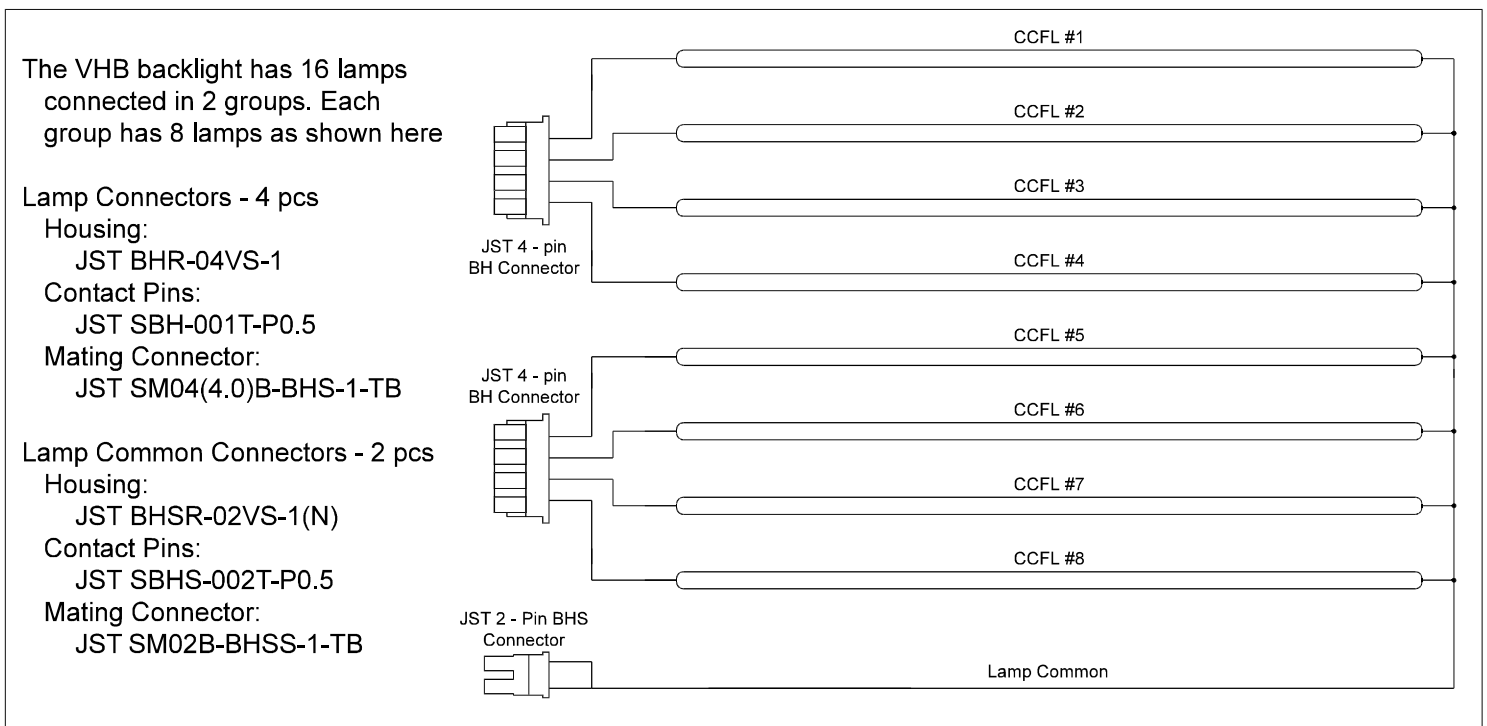

The Landmark BI528A inverter is specially designed to operate the VHB backlight of the LM1970240UW04 LCD module. The BI528A inverter requires 24 V DC input. At the full LCD screen luminance setting, the current input to the inverter is about 4.3 Amperes. At this level, the LCD screen luminance (brightness) is 1,300 nits and the backlight power consumption is about 78 Watts. When the LCD luminance is adjusted down, the power consumption of the backlight decreases proportionally.

**Warning** - The BI528A inverter has an output voltage of about 1,800 Vrms which starts the long CCFLs used in this 24" LCD module. This high voltage is extremely dangerous. To protect users, the high voltage areas of the inverters are fully shielded with a metal cover. If any service work is performed that requires removal of the metal cover, please do not touch any exposed metal parts that may carry the high voltage. Please refer to the BI528A inverter data sheets for the high voltage areas on the inverter board.

### Backlight Life

When the lamps in the LM197-240UW04 backlight are operating at the recommended current for full LCD screen luminance, they are rated at 50,000 hours of half brightness life. The half brightness life is the number of operating hours before the CCFL surface luminance drops down to 50% of its initial value.

In general, the luminance of a backlight decays slightly faster than that of a CCFL. This is due to the aging of other materials in the backlight. However, in actual applications, the luminance of a VHB display will likely be adjusted down in dimly lit environments. Since the half brightness life increases rapidly when lamps are operated at reduced current levels for lower LCD screen luminance, the actual operating lifetime of the backlight in this LCD module can be expected to reach beyond 50,000 hours. For detailed descriptions on backlight life issues and actual test data on Landmark Technology backlights, please refer to Technote TK801.

### Thermal Management

The backlight power consumption of the LM197-240UW04 LCD module is approximately 78 Watts at full brightness. As a result, the LCD screen temperature will be higher than normal. It is necessary to dissipate the backlight heat so that the LCD temperature stays within the temperature specifications of the AUO M240UW04 V0 LCD.

The exact increase in screen temperature depends on the installation of the LCD module in the equipment. The LCD module alone can be operated at 1,300 nits in open air without any cooling. However, when it is installed in a case, some type of cooling measure should be implemented.

For outdoor display applications where the LCD may be subject to direct sunlight exposure, the major source of heat usually comes from sunlight. LCDs are suitable for outdoor applications because they have a low reflective, black front surface. However, a black surface is also a good solar energy absorber. For example, if strong sunlight shines on the LM197-240UW04 LCD module at a perpendicular direction, the LCD module can absorb up to 190 Watts of solar power. This is about twice the total power consumption of the VHB backlight plus the inverter loss. As a result, the LCD temperature can rise very quickly beyond its maximum tolerance level. Please refer to Landmark Technote TK1199 for more details.

It is recommended that the LCD screen temperature be measured at full brightness in the equipment under actual operating environments. The cooling measure should then be designed accordingly. Please ensure that the specified maximum LCD temperature is not exceeded.

#### Disclaimer

Landmark Technology Inc. reserves the right to make changes to this document and the product which it describes without notice. In addition, Landmark Technology Inc. shall not be liable for technical or editorial errors or omissions made herein; nor for incidental or consequential damages resulting from the furnishing, performance, and use of this product.

This product shall not be used for or in connection with equipment that requires an extremely high level of reliability, such as military and aerospace applications, telecommunication equipment, nuclear power control equipment and medical or other life support equipment. Landmark Technology Inc. takes no responsibility for damage caused by improper use of this product which does not meet the conditions for use specified in this specification sheet.

### LCD Module Mechanical Dimensions

