

Introduction

The LMG252-104XA02 is a 10.4" Super bright LCD module. The module consists of a 10.4" TFT color LCD panel with XGA (1,024 x 768) resolution and a SHB (super high brightness) LED backlight in a side mount semi-rugged package of about 10 mm thickness.

At the maximum backlight power of 18.5 Watts, the LMG252-104XA02 delivers a super high screen brightness of 2,500 Cd/m² (nits). At this level, the display is highly readable under direct sunlight. For applications in dark environments, the screen brightness can be adjusted down to less than 20 Cd/m² using a proper LED drive board with PWM dimming control.

Characteristics (Note 1)

Parameters	Typical Value	Units	Conditions
LCD Screen Luminance	2,500	Cd/m ²	LCD displaying the brightest white
Luminance Variation	±15% or better		Note 2
Backlight Power Consumption	18.5	Watts	Excluding LED driving board losses
Typical LCD Contrast Ratio	520:1		White vs. Black (measured in the dark at the normal direction)
Typical Viewing Angles			
3:00 to 9:00 direction	> ± 70	Degrees	Contrast ratio ≥ 10
6:00 to 12:00 direction	> ± 60	Degrees	Contrast ratio ≥ 10
LCD Screen Chromaticity (x, y)			
White	(0.260, 0.300)		Measured at the normal direction
Red	(0.519, 0.331)		Measured at the normal direction
Green	(0.307, 0.576)		Measured at the normal direction
Blue	(0.134, 0.101)		Measured at the normal direction
LCD Module Weight	600	Grams	
Display Resolution	1,024 x 768		
Operating Temperature Range	-20 to 70	°C	

Note 1: All data are measured at 25°C ± 2°C ambient temperature.

Note 2: Screen luminance is measured at 9 points at the locations shown in the drawing on the right. The luminance variation is the percent deviation of the maximum and minimum values measured versus the average value of the 9 points.

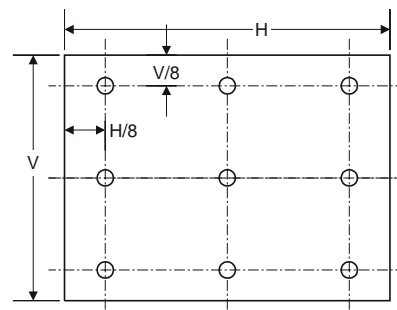

LCD Module Optical Performances

Luminance & Contrast Ratio

The typical LMG252-104XA02 LCD module screen luminance and contrast ratio are shown in the figures below: Since the TFT LCD used in LMG252 module is a normally white LCD, the screen luminance is measured with the LCD in the “Off” state (i.e. the pixels are not energized). This is the “white” state with the maximum possible luminance.

LMG252-104XA02 Screen Luminance
Angular Distribution

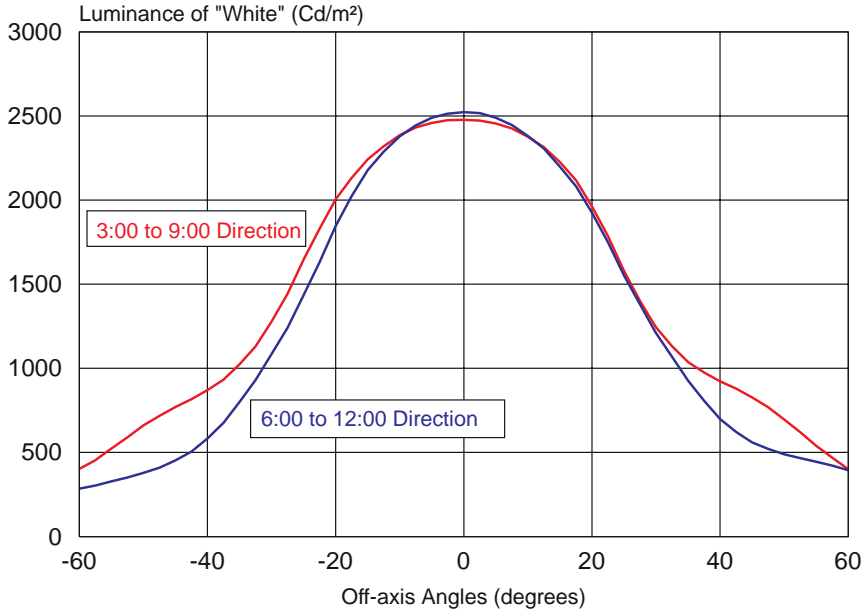

The “white” color displayed on the screen when the video signal is applied may have a slightly lower luminance. When the LCD is properly driven, the luminance of the “white” color displayed on the screen should be within 5% of the specified value.

The LMG252 LCD module has a contrast ratio (CR) about 520:1 along the normal direction. This is the inherent CR measured in a dark room. As the ambient lighting level increases, the CR value drops due to reflection and glare at the front surface of the LCD.

Chromaticity

The 1931 CIE chromaticity coordinates of the R, G, B primary colors are presented in the table on page 1. These numbers are measured from a viewing direction normal to the LCD screen.

The figures on the next page present the chromaticity (x, y) data of the R, G, B primary color displayed on the screen versus the viewing angles.

Along the 3:00 to 9:00 (horizontal) directions, the chromaticity values do not change a great deal. Thus, the color shift along the horizontal direction is small.

Along the 6:00 to 12:00 (vertical) directions, the red and green primary colors have significant changes as the viewing angles reach 35° off axis, in particular, the red primary

LMG252-104XA02 LCD Contrast Ratio
Angular Distribution

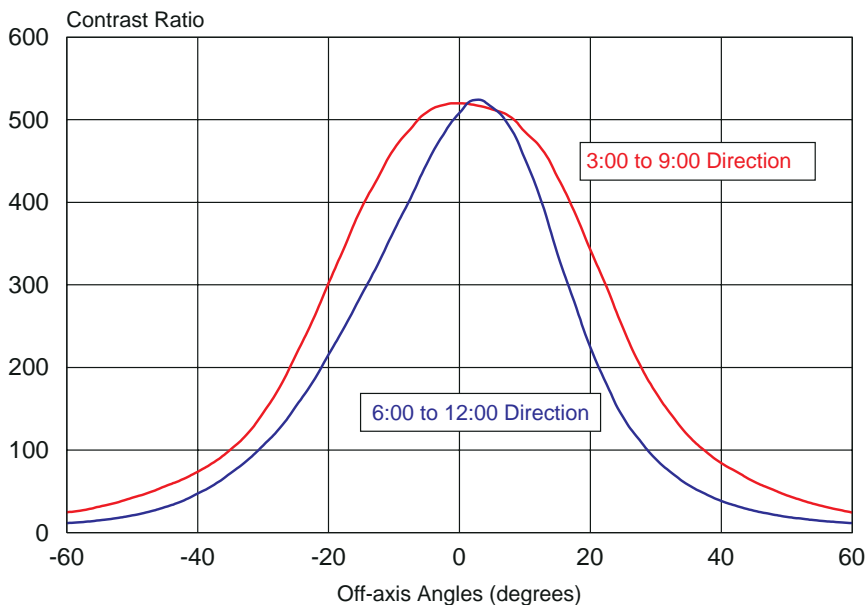

color along the 6:00 direction. As a result, the image on the screen maintains a fairly good color along the horizontal directions as well as along the 12:00 direction up to 40° off axis viewing angles. Along the 6:00 direction, the color shift is quite significant for viewing angles beyond 35°.

LMG252-104XA02 Color Shift along the 3:00 - 9:00 Directions
(Positive Angles are along the 3:00 Direction)

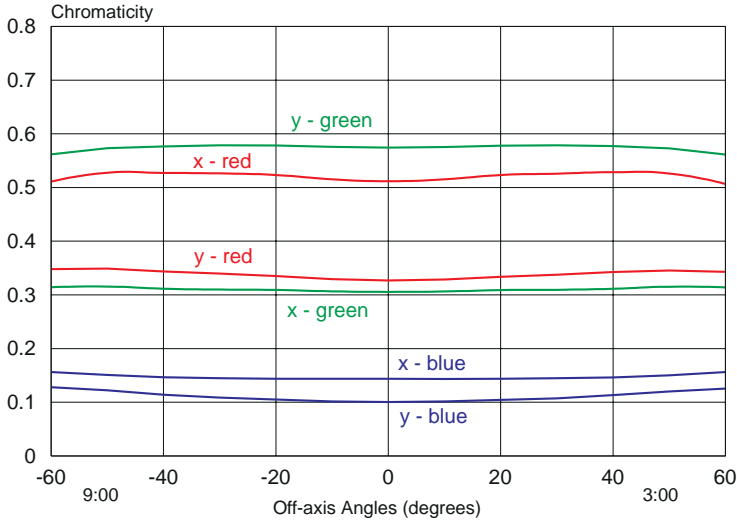

LMG252-104XA02 Color Shift along the 6:00 - 12:00 Directions
(Positive Angles are along the 6:00 Direction)

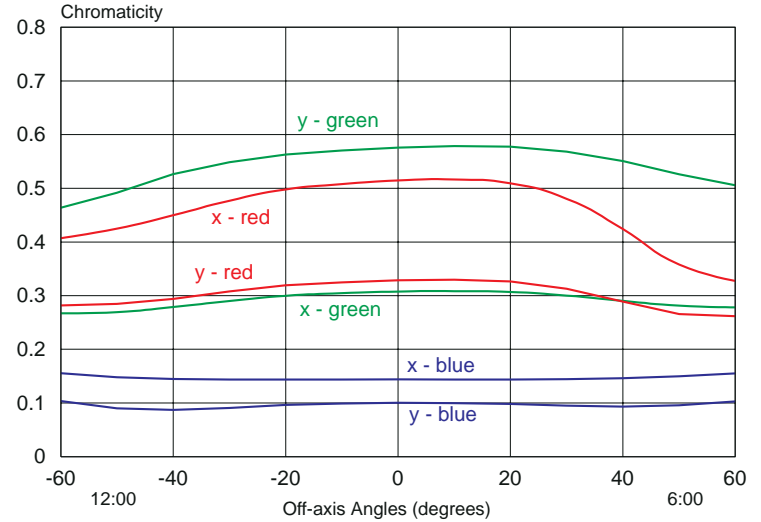

LED Backlight Driving Specifications

The LMG252 LCD module has a SHB backlight with two LED lamp strips. Each LED strip has 27 white LEDs that are electrically connected into 3 strings in parallel. Each string has 9 LEDs connected in series.

Each LED strip is terminated with a JST 2-pin connector, BHRS-02VS-1. The JST mating connector part number is SM02-BHSS-1-TB.

At the maximum screen brightness setting of 2,500 nits,

the driving conditions of each LED strip (with 6 strings) are,

LED strip driving voltage	28	Vdc (typ)
LED strip driving current	330	mA

Thus, the 2 LED strips in the backlight consume about 18.5 Watts. With Landmark’s LD200A LED driving board (tuned for the LMG216H), the total power drain from the 12V supply is 21.5 Watts.

Thermal Management

The backlight power consumption of the LMG252-104XA02 LCD module is approximately 18.5 Watts at full screen brightness. As a result, the LCD screen temperature will be higher than normal. The exact increase of temperature depends on the installation of the LCD module in the equipment. When the LMG252 is operated at full brightness in open air without air flow, the LCD front surface temperature is about 15 to 20°C above the ambient temperature.

For outdoor applications with direct sunlight exposure, the black front surface of the LCD is a good solar power absorber. Under the worst case scenario, a 10.4" LCD can absorb 35 Watts of solar power which is nearly twice the backlight power at full brightness. The combined heating power from the sunlight and the SHB backlight can raise the

Thermal Management (continued)

LCD temperature, possibly beyond 80°C. Also, both LED efficiency in Lumens per Watt and LED life span decrease when the ambient temperature rises beyond a certain level. Thus, please implement cooling measures to maintain the LCD temperature well below 70 °C to ensure good display performance and long LED backlight life span.

For outdoor applications in cold winter weather, the ambient temperature may drop to below -20°C. Therefore, the thermal management (cooling and heating) system should be designed according to the worst case conditions anticipated for the LCD to ensure that the LMG252 is operated within the -20 to 70° temperature range.

Backlight Life

The half brightness life of the VHB backlight in the LMG252-104XA02 sunlight readable module is rated at 50,000 hours. The half brightness life is the number of operating hours before the backlight luminance (seen as the LCD screen brightness) drops down to 50% of its initial value.

The lifetime of an LED backlight is mainly determined by the luminous decay of the LEDs. As the temperature of the LED chip rises, the LED luminance decay accelerates. This temperature effect on the LED life is relatively small if the LCD case temperature is maintained below 50 °C.

Caution:

The LMG252-104XA02 is a side mount LCD module. The locations of the mounting holes and the screw size are specified in the Mechanical Dimensions Drawing on the next page. Please use four M3 screws to mount the LMG252 LCD onto the display case.

The maximum depth of the screws penetrating inside the LCD module is 4 mm. The maximum torque used to tighten the screws is 3.5 Kg-cm (3 lb-in). Excessive torque and longer screws can cause severe damage to the LCD module.

Disclaimer

Landmark Technology Inc. reserves the right to make changes to this document and the product which it describes without notice. In addition, Landmark Technology Inc. shall not be liable for technical or editorial errors or omissions made herein; nor for incidental or consequential damages resulting from the furnishing, performance, and use of this product.

This product shall not be used for or in connection with equipment that requires an extremely high level of reliability, such as military and aerospace applications, telecommunication equipment, nuclear power control equipment and medical or other life support equipment. Landmark Technology Inc. takes no responsibility for damage caused by improper use of this product which does not meet the conditions for use specified in this specification sheet.

LMG252-104XA02 Mechanical Dimensions

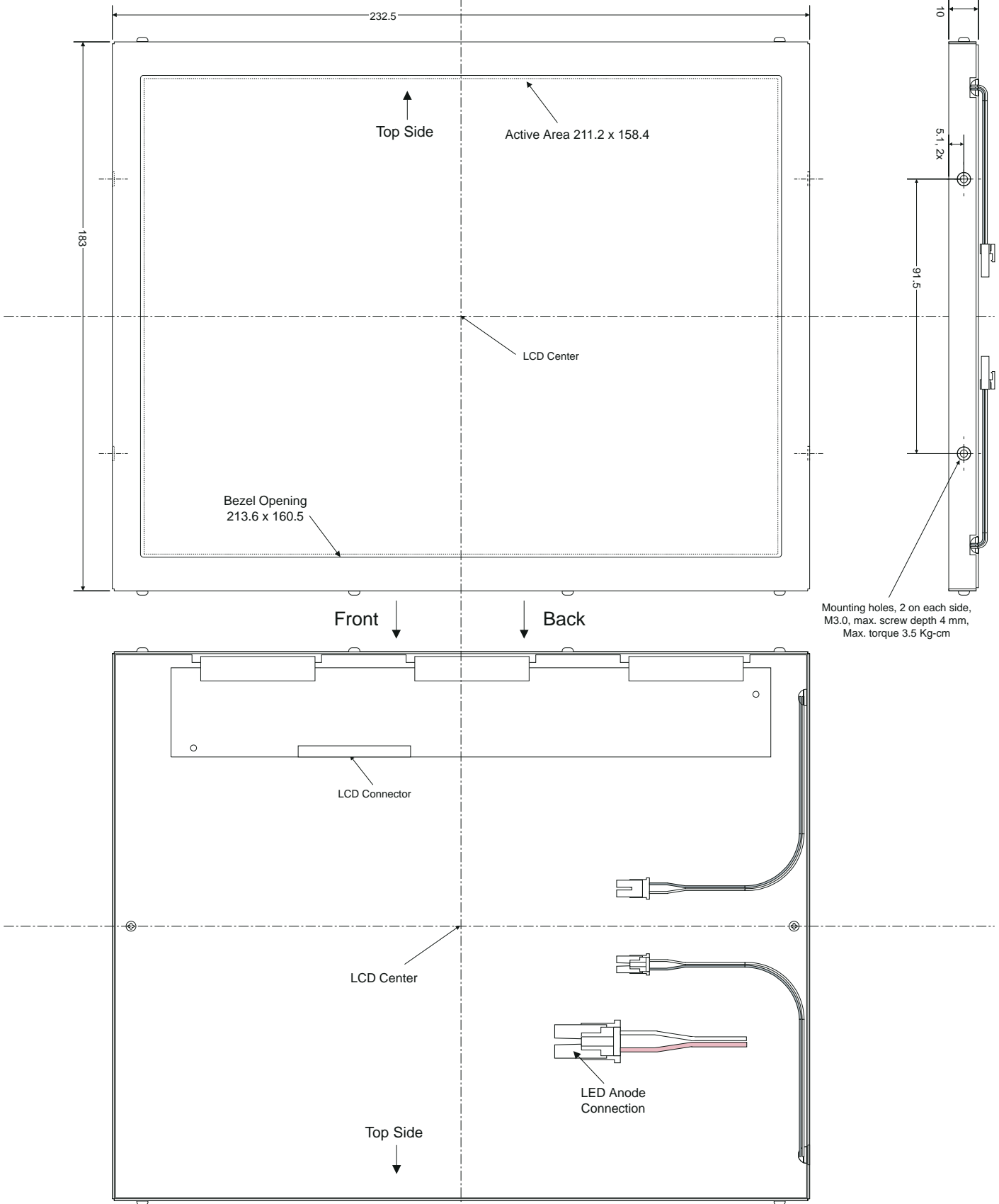

All dimensions are in mm