

6 Channel Low Capacitance ESD Protection Diode Array

HYESD1065 is a 6-channel ultra low capacitance ESD protection diode array which includes surge rated to protect high speed data lines. Each channel consists of a pair of ESD diodes that steer positive or negative ESD current to either the positive or negative rail. Typical application, the negative rail pin (Assigned as GND) is connected with system ground. The Positive ESD current is steered to the ground through an ESD diode and Zener diode and the positive ESD voltage is clamped to the zener voltage.

FEATURES

- 6 Channel ESD protection for high speed data line
- Provides ESD protection to IEC61000-4-2 level 4
 - $\pm 15\text{KV}$ Air Discharge
 - $\pm 8\text{KV}$ Contact Discharge
- Ultra low capacitance
 - I/O to GND : 0.4pF (Max)
 - I/O to I/O : 0.25pF (Max)
- Low clamping voltage & 5V operation voltage

APPLICATION

- HDMI / DVI ports
- Display port
- USB 3.0 port
- Flat panel Monitors / TVs
- Cellular Handsets & Accessories
- PCI Express

MECHANICAL INFORMATION

- Case : MSOP-8 / DFN-10-4.1x2.0x0.5 Package
- Pb-Free, Halogen Free, RoHS/WEEE Compliant

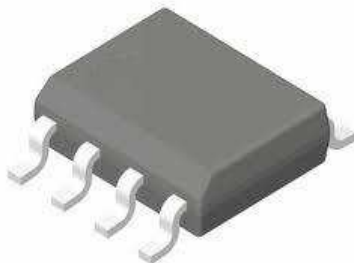

HYESD1065M
MSOP-8

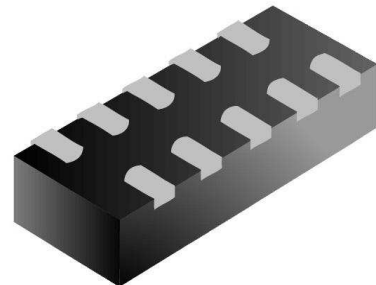

HYESD1065P
DFN-10

PIN CONFIGURATION

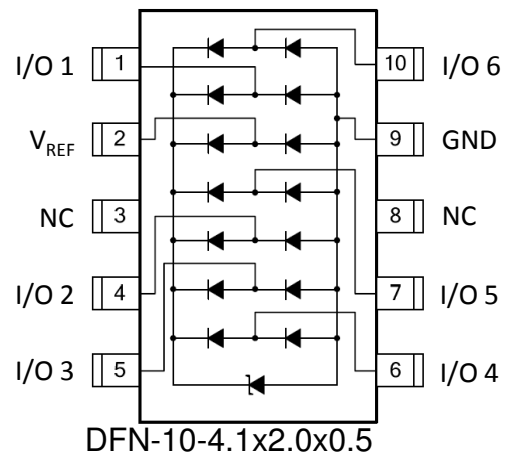
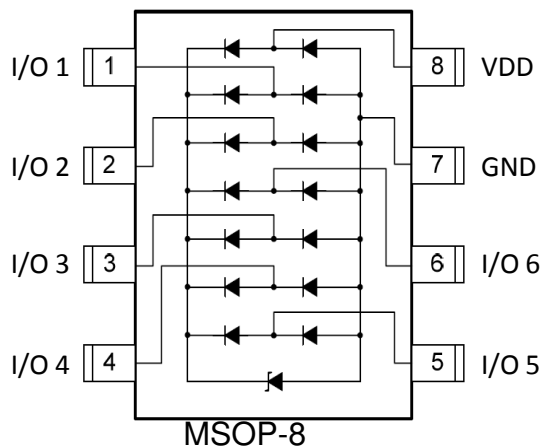

Maximum Rating and Thermal Characteristics ($T_C=25^\circ\text{C}$)

Parameter	Symbol	Value	Unit
Peak Pulse Power(8/20 μs)	P_{PP}	150	W
Peak Pulse Current(8/20 μs)	I_{PP}	5	A
ESD per IEC 61000-4-2(Air)	V_{ESD}	$\pm 15\text{KV}$	V
ESD per IEC 61000-4-2(Contact)	V_{ESD}	$\pm 8\text{KV}$	V
Operating Temperature Range	T_{op}	-55 to +125	$^\circ\text{C}$
Storage Temperature Range	T_{stg}	-55 to +150	$^\circ\text{C}$

Electrical Characteristics ($T_C=25^\circ\text{C}$, unless otherwise noted)

Parameter	Symbol	Test Condition	Min	Typ	Max	Unit
Reverse Working Voltage	V_{RWM}	Any I/O pin to GND	-	-	5	V
Reverse Breakdown Voltage	V_{BR}	$I_{BR} = 1\text{mA}$; I/O pin to GND	6	-		V
Reverse Leakage Current	I_R	$V_{RWM} = 5\text{V}$, $T = 25^\circ\text{C}$; I/O pin to GND	-	-	1	μA
Positive Clamping Voltage	V_C	$I_{PP} = 1\text{A}$, $t_p = 8/20\mu\text{s}$; Positive pulse; Any I/O pin to GND	-	8.5	12	V
Negative Clamping Voltage	V_C	$I_{PP} = 1\text{A}$, $t_p = 8/20\mu\text{s}$; Negative pulse; Any I/O pin to GND	-	1.8	-	V
Junction Capacitance Between Channel	C_J	$V_R = 0\text{V}$, $f = 1\text{MHz}$; Between I/O pins	-	0.2	0.25	pF
Junction Capacitance Between I/O And GND	C_J	$V_R = 0\text{V}$, $f = 1\text{MHz}$; Any I/O pin to GND	-	-	0.4	pF

Typical Characteristic Curves ($T_j=25^{\circ}\text{C}$, UNLESS OTHERWISE NOTED)

FIG.1 - Power Derating Curve

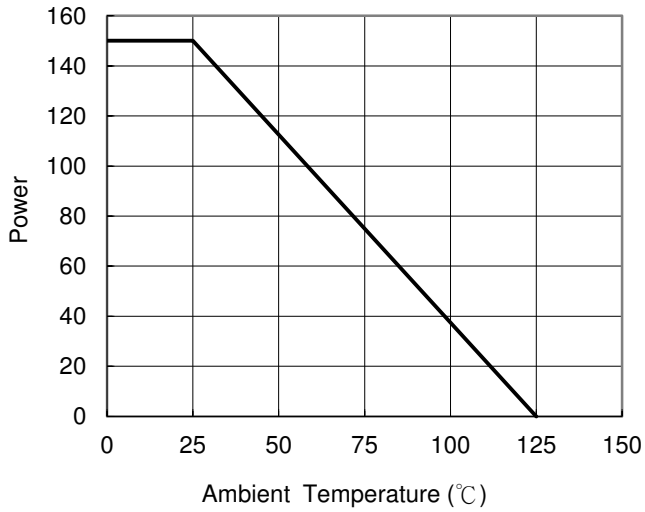

FIG.2 - Pulse Waveform

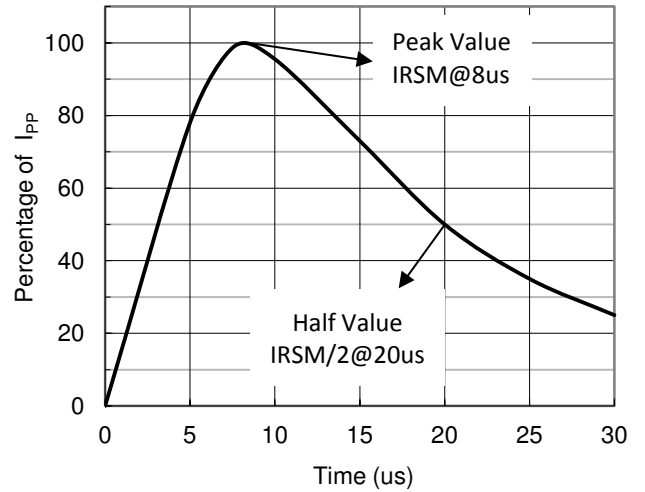

FIG.3 - Junction Capacitance vs. Reverse Voltage

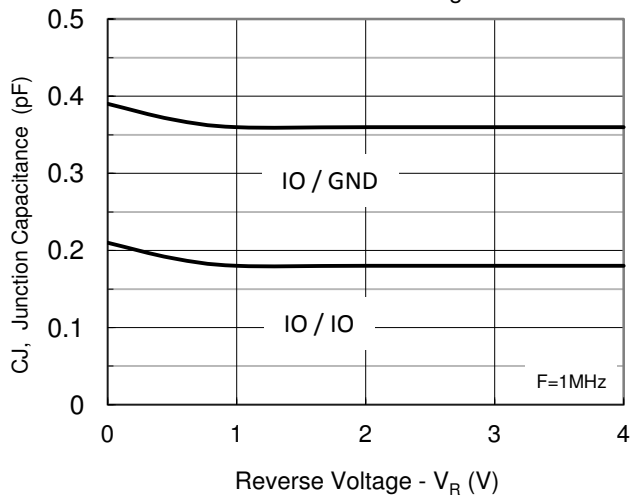
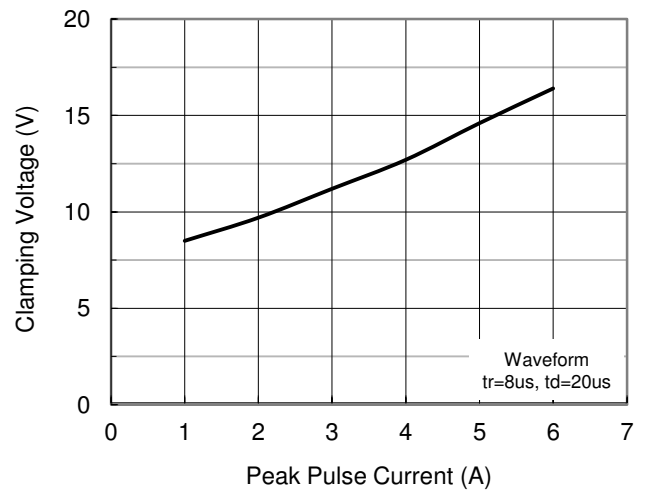

FIG.4 - Clamping Voltage vs. Peak Pulse Current



Order & Marking Information

Part Number	Package	Marking	Packing	Q'ty
HYESD1065M	MSOP-8	1065	13" Reel	3K
HYESD1065P	DFN-10-4.1x2.0x0.5	65P	7" Reel	3K

Package Outline Dimension

MSOP-8 Package

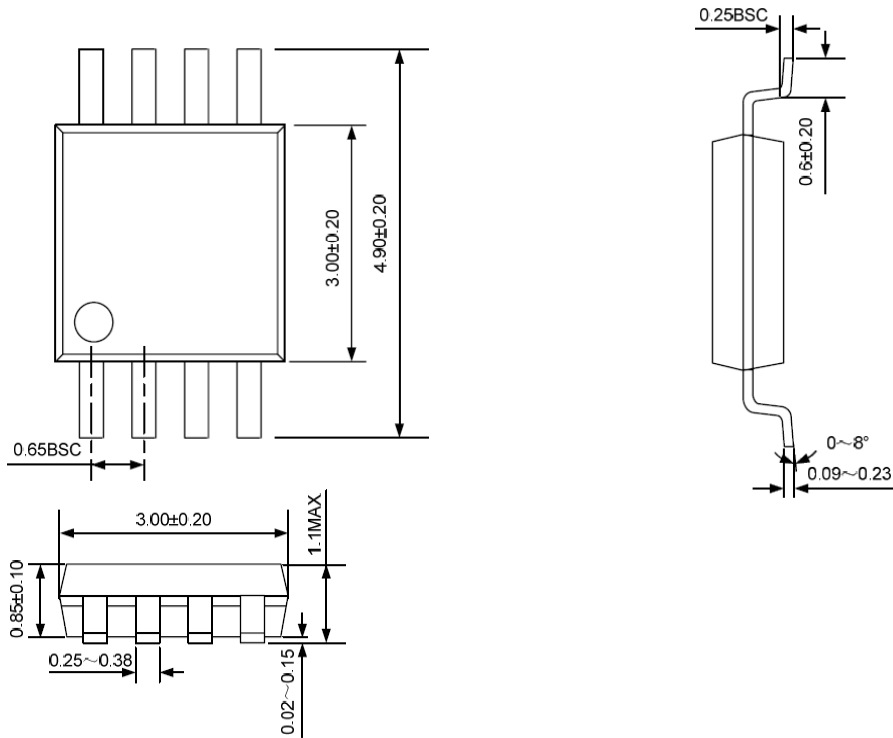

DFN-10 Package

