

SCHOTTKY BARRIER RECTIFIERS

REVERSE VOLTAGE - 100Volts
FORWARD CURRENT - 20.0 Amperes

FEATURES

- Metal of silicon rectifier , majority carrier conduction
- Guard ring for transient protection
- Low power loss,high efficiency
- High current capability,low VF
- High surge capacity
- Plastic package has UL flammability classification 94V-0
- For use in low voltage,high frequency inverters,free wheeling,and polarity protection applications

MECHANICAL DATA

- Case: TO-220AB molded plastic
- Polarity: As marked on the body
- Weight: 0.08ounces,2.24 grams
- Mounting position :Any

TO-220AB

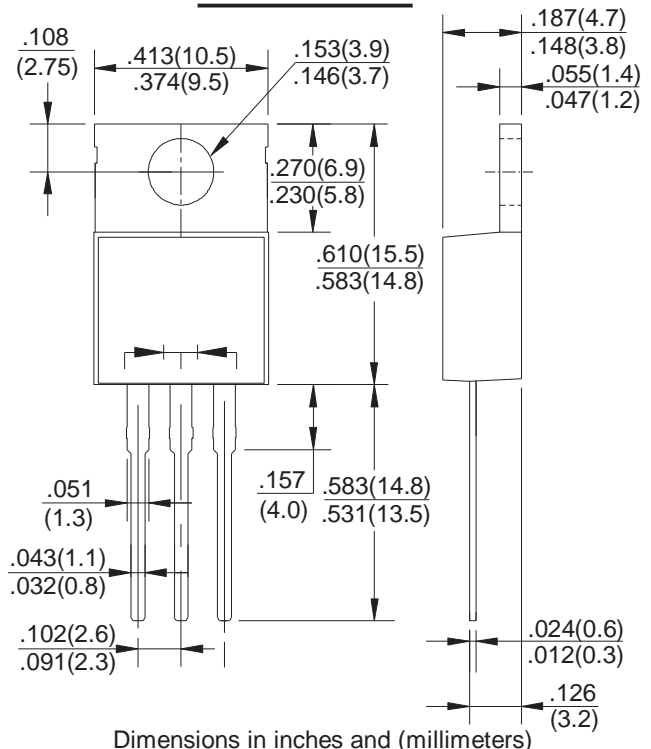

MAXIMUM RATINGS AND ELECTRICAL CHARACTERISTICS

Rating at 25°C ambient temperature unless otherwise specified.

Single phase, half wave ,60Hz, resistive or inductive load.

For capacitive load, derate current by 20%

CHARACTERISTICS	SYMBOL	HSB20U100CT	UNIT
Maximum Recurrent Peak Reverse Voltage	V _{RRM}	100	V
Maximum RMS Voltage	V _{RMS}	70	V
Maximum DC Blocking Voltage	V _{DC}	100	V
Maximum Average Forward Rectified Current (See Fig.1)	I <sub(av)< sub=""></sub(av)<>	20.0	A
Peak Forward Surge Current 8.3ms Single Half Sine-Wave Super Imposed on Rated Load (JEDEC Method)	I _{FSM}	150	A
Peak Forward Voltage (Note1)	V _F	0.7 0.63 0.82	V
Maximum DC Reverse Current at Rated DC Bolcking Voltage	I _R	0.5 25	mA
Typical Junction Capacitance (Note2)	C _J	320	pF
Typical Thermal Resistance (Note3)	R _{θJC}	3.5	°C/W
Operating Temperature Range	T _J	-55 to +150	°C
Storage Temperature Range	T _{STG}	-55 to +175	°C

NOTES:1.300us pulse width,2% duty cycle.

2.Measured at 1.0 MHz and applied reverse voltage of 4.0V DC.

3.Thermal resistance junction to case.

FIG. 1 – FORWARD CURRENT DERATING CURVE

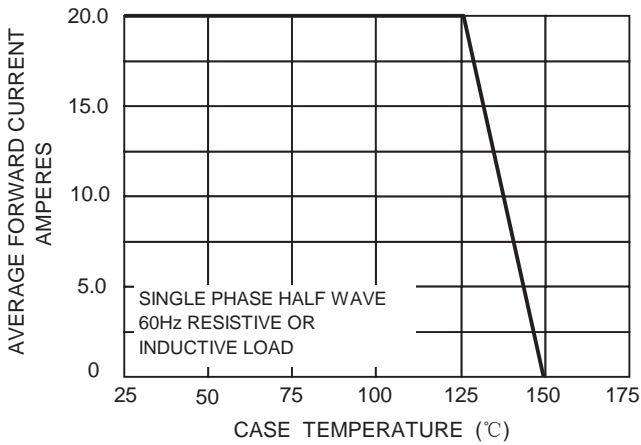

FIG. 2 – MAXIMUM NON-REPETITIVE SURGE CURRENT

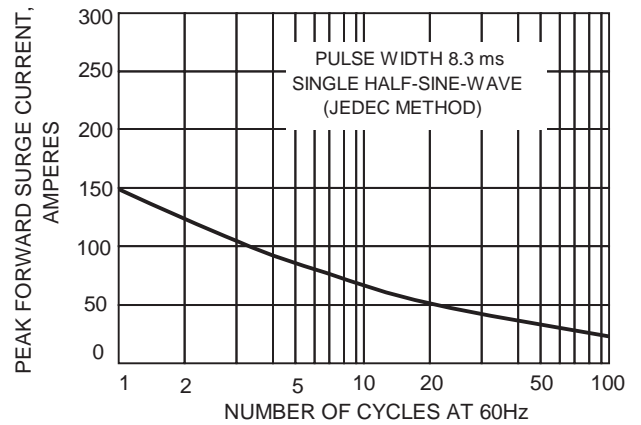

FIG.3-TYPICAL REVER CHARACTERISTICS

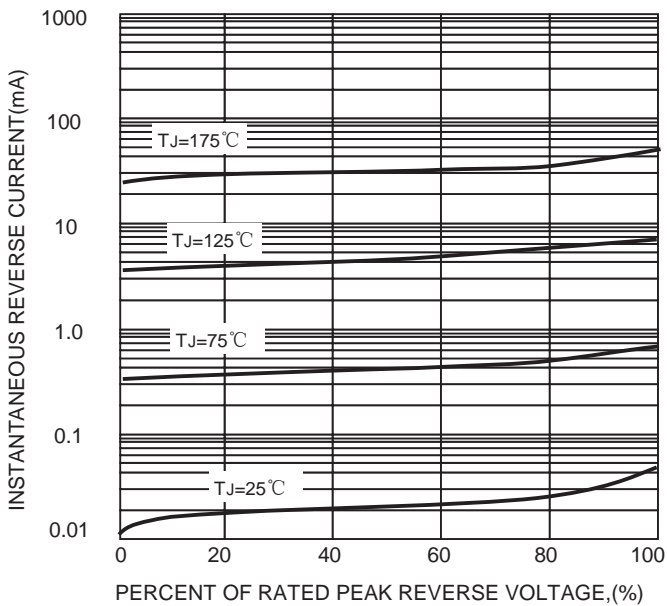

FIG.4-TYPICAL FORWARD CHARACTERISTICS

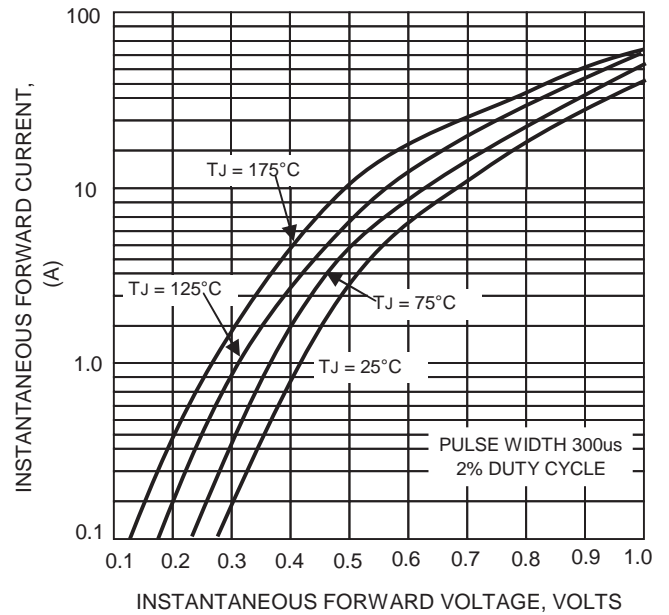

FIG.5 – TYPICAL JUNCTION CAPACITANCE

