



# SR4030PT thru SR40150PT

<b>SCHOTTKY BARRIER RECTIFIERS</b>	<b>REVERSE VOLTAGE - 30 to 150Volts</b> <b>FORWARD CURRENT - 40.0 Amperes</b>
------------------------------------	--

**FEATURES**

- Metal of silicon rectifier , majority carrier conduction
- Guard ring for transient protection
- Low power loss,high efficiency
- High current capability,low VF
- High surge capacity
- Plastic package has UL flammability classification 94V-0
- For use in low voltage,high frequency inverters,free wheeling,and polarity protection applications

**MECHANICAL DATA**

- Case: TO-3P molded plastic
- Polarity: As marked on the body
- Weight: 0.2ounces,5.6 grams
- Mounting position :Any

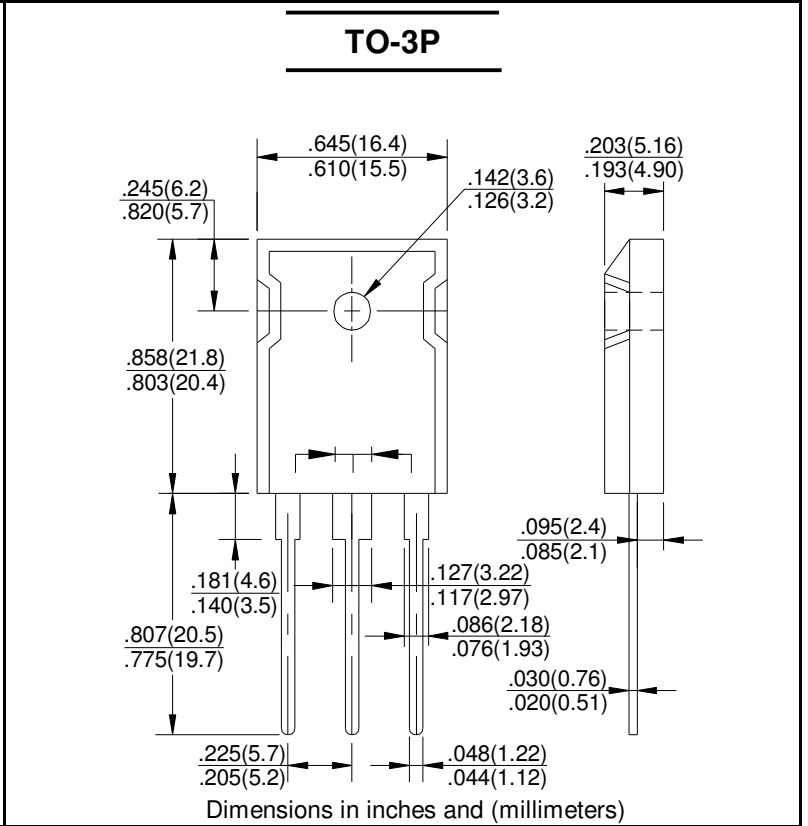

## MAXIMUM RATINGS AND ELECTRICAL CHARACTERISTICS

Rating at 25°C ambient temperature unless otherwise specified.

Single phase, half wave ,60Hz, resistive or inductive load.

For capacitive load, derate current by 20%

CHARACTERISTICS	SYMBOL	SR	SR	SR	SR	SR	SR	SR	UNIT
		4030PT	4040PT	4050PT	4060PT	4080PT	40100PT	40150PT	
Maximum Recurrent Peak Reverse Voltage	V <sub>RRM</sub>	30	40	50	60	80	100	150	V
Maximum RMS Voltage	V <sub>RMS</sub>	21	28	35	42	56	70	105	V
Maximum DC Blocking Voltage	V <sub>DC</sub>	30	40	50	60	80	100	150	V
Maximum Average Forward Rectified Current ( See Fig.1) @T <sub>C</sub> =100°C	I <sub>(AV)</sub>	40							A
Peak Forward Surge Current 8.3ms Single Half Sine-Wave Super Imposed on Rated Load (JEDEC Method)	I <sub>FSM</sub>	350							A
Peak Forward Voltage at 20.0A DC	V <sub>F</sub>	0.55		0.70		0.85		0.95	V
Maximum DC Reverse Current @T <sub>J</sub> =25°C at Rated DC Bolcking Voltage @T <sub>J</sub> =100°C	I <sub>R</sub>	1.0 100							mA
Typical Junction Capacitance (Note1)	C <sub>J</sub>	800							pF
Typical Thermal Resistance (Note2)	R <sub>θJC</sub>	1.4							°C/W
Operating Temperature Range	T <sub>J</sub>	-55 to + 150							°C
Storage Temperature Range	T <sub>STG</sub>	-55 to + 150							°C

NOTES: 1.Measured at 1.0 MHz and applied reverse voltage of 4.0VDC.

2.Thermal resistance junction to case.

**RATING AND CHARACTERISTIC CURVES**  
**SR4030PT thru SR40150PT**



FIG. 1 – FORWARD CURRENT DERATING CURVE

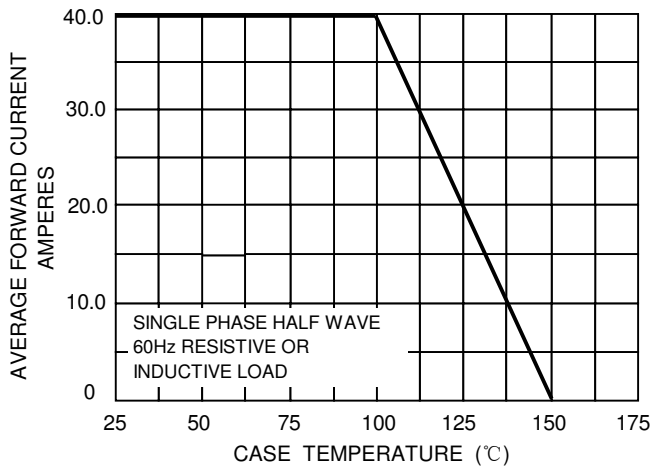

FIG. 2 – MAXIMUM NON-REPETITIVE SURGE CURRENT

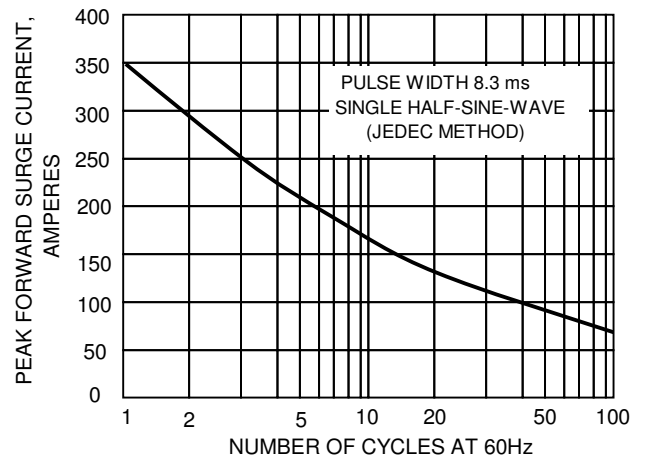

FIG.3-TYPICAL REVER CHARACTERISTICS

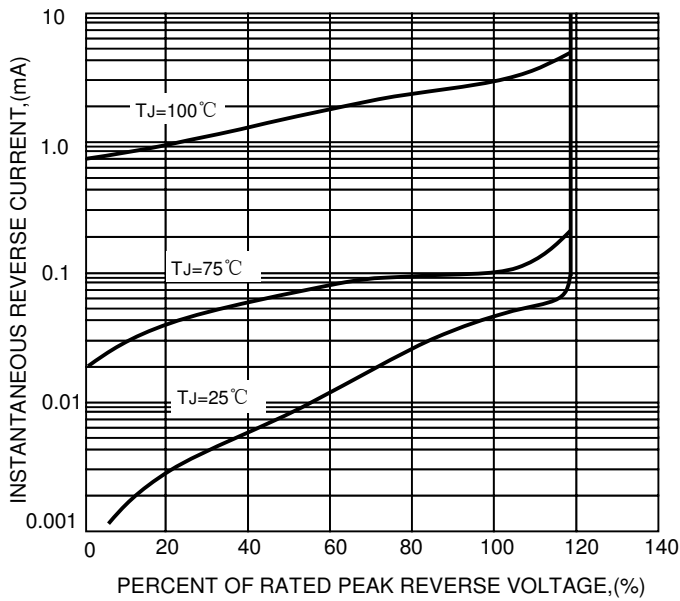

FIG.4-TYPICAL FORWARD CHARACTERISTICS

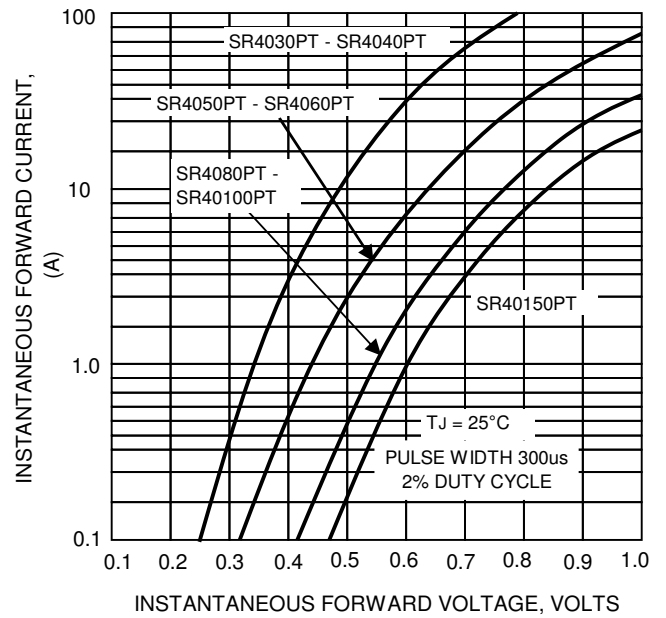

FIG.5 – TYPICAL JUNCTION CAPACITANCE

