

SCHOTTKY BARRIER RECTIFIERS	REVERSE VOLTAGE - 30 to 150Volts FORWARD CURRENT - 30.0 Amperes
------------------------------------	--

FEATURES

- Metal of silicon rectifier , majority carrier conduction
- Guard ring for transient protection
- Low power loss,high efficiency
- High current capability,low VF
- High surge capacity
- Plastic package has UL flammability classification 94V-0
- For use in low voltage,high frequency inverters,free wheeling,and polarity protection applications

MECHANICAL DATA

- Case: TO-3P molded plastic
- Polarity: As marked on the body
- Weight: 0.2ounces,5.6 grams
- Mounting position :Any

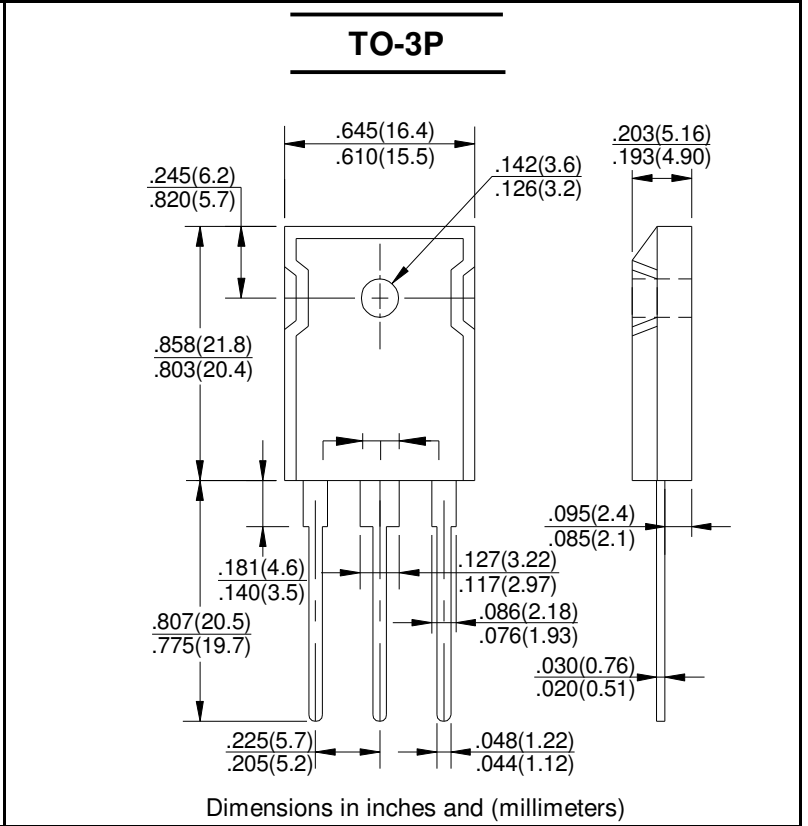

MAXIMUM RATINGS AND ELECTRICAL CHARACTERISTICS

Rating at 25°C ambient temperature unless otherwise specified.
 Single phase, half wave ,60Hz, resistive or inductive load.
 For capacitive load, derate current by 20%

CHARACTERISTICS	SYMBOL	SR 3030PT	SR 3040PT	SR 3050PT	SR 3060PT	SR 3080PT	SR 30100PT	SR 30150PT	UNIT	
Maximum Recurrent Peak Reverse Voltage	V _{RRM}	30	40	50	60	80	100	150	V	
Maximum RMS Voltage	V _{RMS}	21	28	35	42	56	70	105	V	
Maximum DC Blocking Voltage	V _{DC}	30	40	50	60	80	100	150	V	
Maximum Average Forward Rectified Current (See Fig.1) @T _C =95°C	I _(AV)	30							A	
Peak Forward Surge Current 8.3ms Single Half Sine-Wave Super Imposed on Rated Load (JEDEC Method)	I _{FSM}	200							A	
Peak Forward Voltage at 15.0A DC	V _F	0.55		0.70		0.85		0.95	V	
Maximum DC Reverse Current @T _J =25°C at Rated DC Bolcking Voltage @T _J =100°C	I _R	1.0							75	mA
Typical Junction Capacitance (Note1)	C _J	700							pF	
Typical Thermal Resistance (Note2)	R _{θJC}	2.0							°C/W	
Operating Temperature Range	T _J	-55 to + 150							°C	
Storage Temperature Range	T _{STG}	-55 to + 150							°C	

NOTES: 1.Measured at 1.0 MHz and applied reverse voltage of 4.0VDC.
 2.Thermal resistance junction to case.

FIG. 1 – FORWARD CURRENT DERATING CURVE

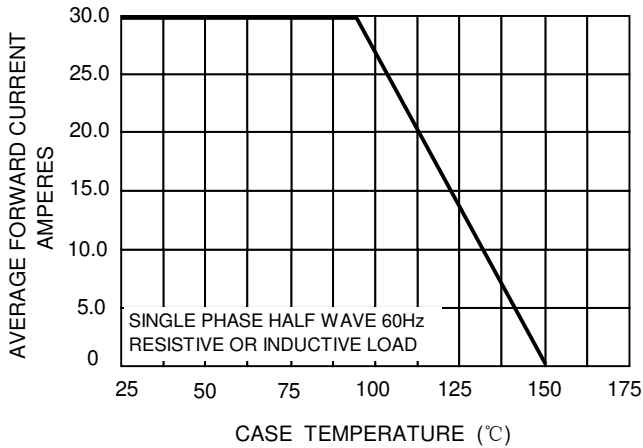

FIG. 2 – MAXIMUM NON-REPETITIVE SURGE CURRENT

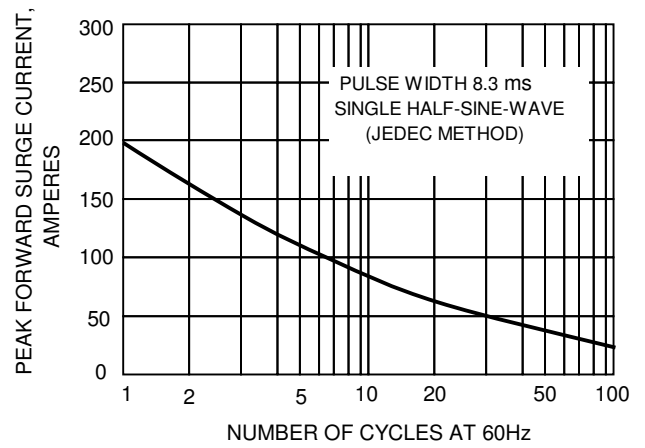

FIG.3-TYPICAL REVER CHARACTERISTICS

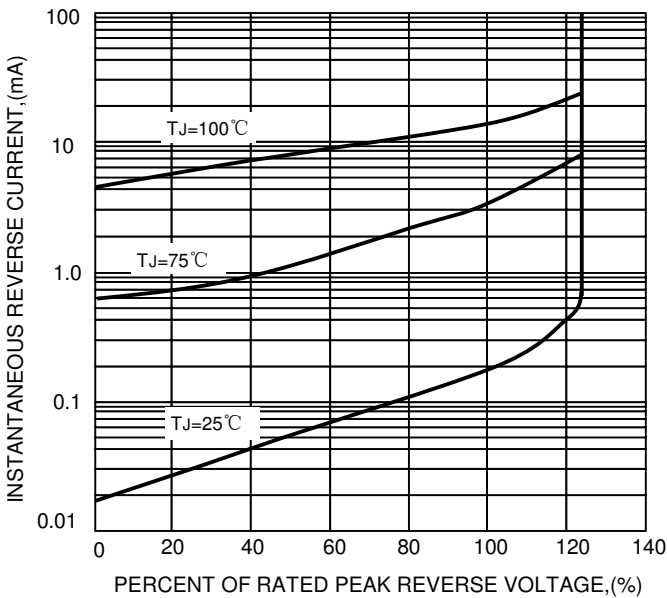

FIG.4-TYPICAL FORWARD CHARACTERISTICS

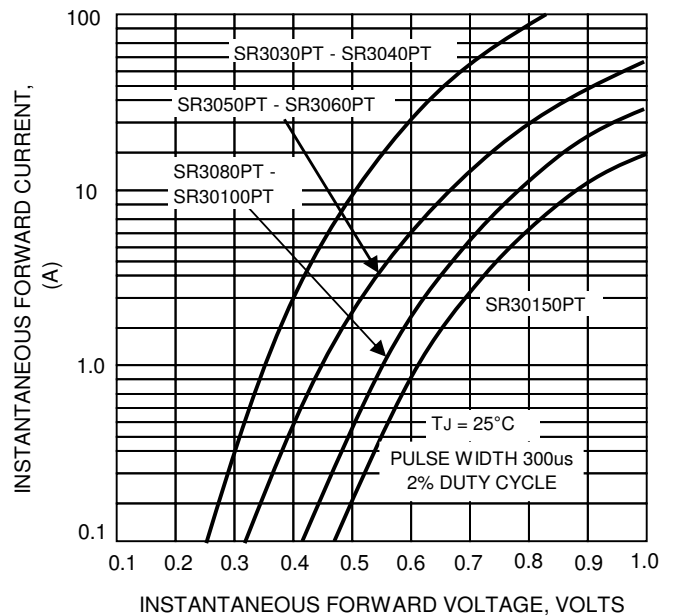

FIG.5 – TYPICAL JUNCTION CAPACITANCE

