

**GLASS PASSIVATED
BRIDGE RECTIFIERS**
**REVERSE VOLTAGE - 1400Volts
FORWARD CURRENT - 2.0 Amperes**
FEATURES

- Rating to 1400V PRV
- Ideal for printed circuit board
- Low forward voltage drop, high current capability
- Reliable low cost construction utilizing molded plastic technique results in inexpensive product
- The plastic material has UL flammability classification 94V-0

MECHANICAL DATA

- Polarity: As marked on Body
- Weight: 0.02 ounces, 0.38 grams
- Mounting position: Any

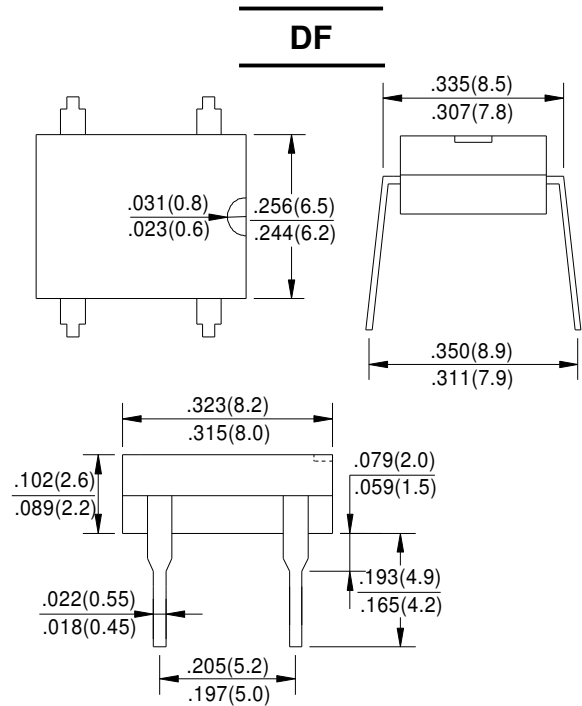

Dimensions in inches and (millimeters)

MAXIMUM RATINGS AND ELECTRICAL CHARACTERISTICS

Rating at 25°C ambient temperature unless otherwise specified.

Single phase, half wave, 60Hz, resistive or inductive load.

For capacitive load, derate current by 20%

CHARACTERISTICS	SYMBOL	DF214	UNIT
Maximum Recurrent Peak Reverse Voltage	V _{RRM}	1400	V
Maximum RMS Voltage	V _{RMS}	980	V
Maximum DC Blocking Voltage	V _{DC}	1400	V
Maximum Average Forward Rectified Current @T _A =40°C	I _(AV)	2.0	A
Peak Forward Surge Current 8.3ms Single Half Sine-Wave Super Imposed on Rated Load (JEDEC .Method)	I _{FSM}	60	A
Maximum Forward Voltage at 2.0A DC	V _F	1.1	V
Maximum DC Reverse Current @T _J =25°C at Rated DC Blocking Voltage @T _J =125°C	I _R	10 500	μA
I ² t Rating for Fusing (t<8.3ms)	I ² t	15	A ² s
Typical Junction capacitance Per Element(Note1)	C _J	25	pF
Typical Thermal Resistance (Note2)	R _{θJA}	40	°C/W
Operating Temperature Range	T _J	-55 to +150	°C
Storage Temperature Range	T _{STG}	-55 to +150	°C

Note:1.Measured at 1.0MHz and applied reverse voltage of 4.0V DC

2.Thermal resistance from junction to ambient mounted on P.C.B with 0.5*0.5"(13*13mm) copper pads.

FIG.1-DERATING CURVE FOR OUTPUT RECTIFIED CURRENT

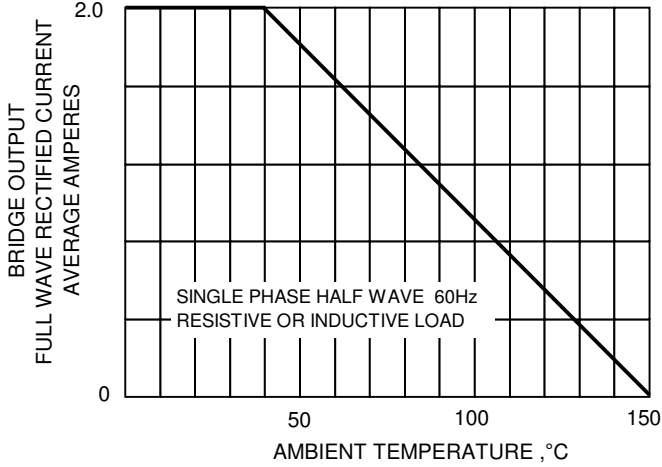

FIG.2-MAXIMUM NON-REPETITIVE PEAK FORWARD SURGE CURRENT

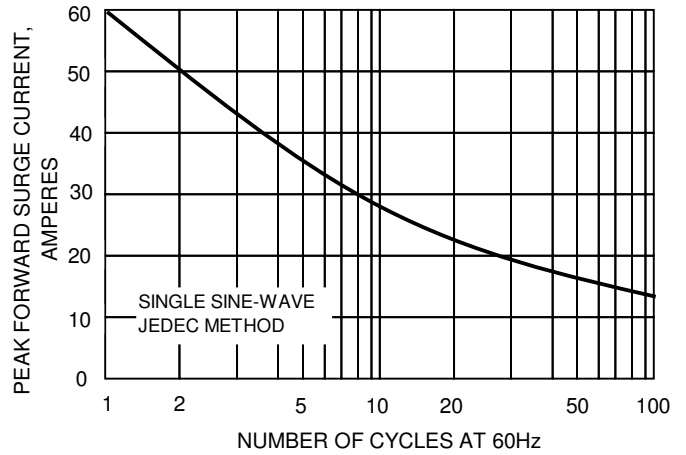

FIG.3-TYPICAL JUNCTION CAPACITANCE

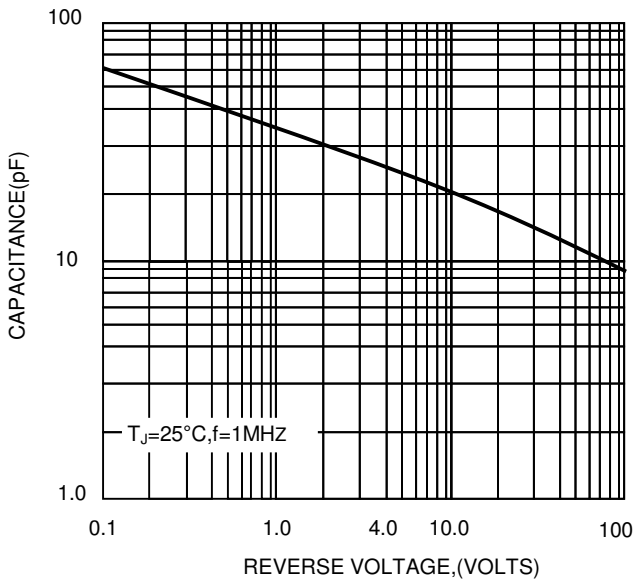

FIG.4-TYPICAL FORWARD CHARACTERISTICS

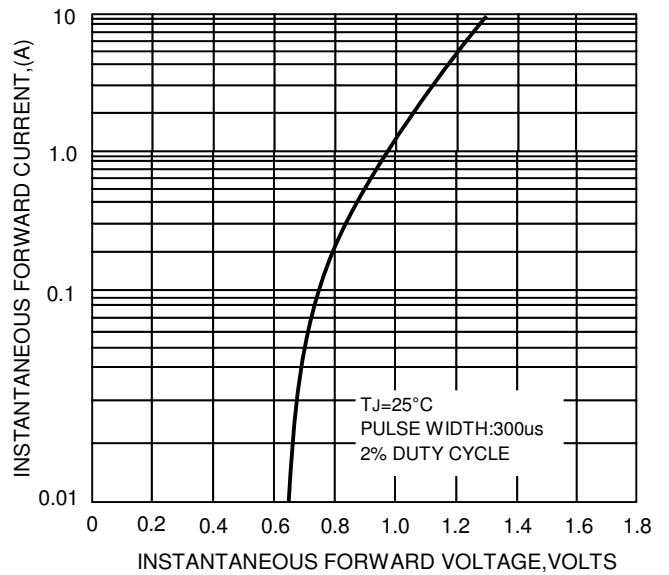

FIG.5-TYPICAL REVERSE CHARACTERISTICS

