

## GLASS PASSIVATED BRIDGE RECTIFIERS

REVERSE VOLTAGE - 50 to 1000 Volts  
FORWARD CURRENT - 1.5 Amperes

### FEATURES

- Rating to 1000V PRV
- Ideal for printed circuit board
- Low forward voltage drop, high current capability
- Reliable low cost construction utilizing molded plastic technique results in inexpensive product
- The plastic material has UL flammability classification 94V-0

### MECHANICAL DATA

- Polarity: As marked on Body
- Weight: 0.02 ounces, 0.38 grams
- Mounting position: Any

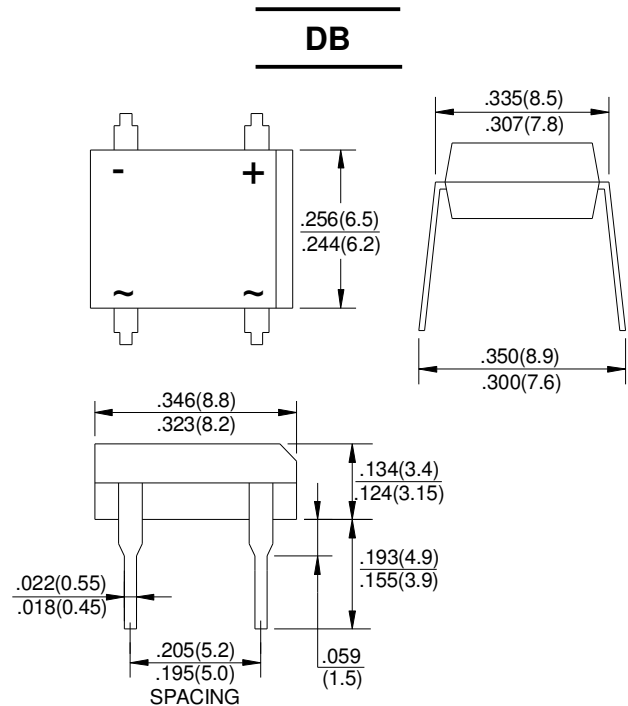

Dimensions in inches and (millimeters)

## MAXIMUM RATINGS AND ELECTRICAL CHARACTERISTICS

Rating at 25°C ambient temperature unless otherwise specified.

Single phase, half wave, 60Hz, resistive or inductive load.

For capacitive load, derate current by 20%

CHARACTERISTICS	SYMBOL	DB151	DB152	DB153	DB154	DB155	DB156	DB157	UNIT
Maximum Recurrent Peak Reverse Voltage	V <sub>RRM</sub>	50	100	200	400	600	800	1000	V
Maximum RMS Voltage	V <sub>RMS</sub>	35	70	140	280	420	560	700	V
Maximum DC Blocking Voltage	V <sub>DC</sub>	50	100	200	400	600	800	1000	V
Maximum Average Forward Rectified Current @T <sub>A</sub> =40°C	I <sub>(AV)</sub>	1.5							A
Peak Forward Surge Current 8.3ms Single Half Sine-Wave Super Imposed on Rated Load (JEDEC Method)	I <sub>FSM</sub>	50							A
Maximum Forward Voltage at 1.5A DC	V <sub>F</sub>	1.1							V
Maximum DC Reverse Current @T <sub>J</sub> =25°C at Rated DC Blocking Voltage @T <sub>J</sub> =125°C	I <sub>R</sub>	10 500							μA
I <sup>2</sup> t Rating for Fusing (t<8.3ms)	I <sup>2</sup> t	10.4							A <sup>2</sup> s
Typical Junction Capacitance Per Element (Note1)	C <sub>J</sub>	25							pF
Typical Thermal Resistance (Note2)	R <sub>θJA</sub>	40							°C/W
Operating Temperature Range	T <sub>J</sub>	-55 to +150							°C
Storage Temperature Range	T <sub>STG</sub>	-55 to +150							°C

Note:1. Measured at 1.0MHz and applied reverse voltage of 4.0V DC.

2. Thermal resistance from junction to ambient mounted on P.C.B. with 0.5\*0.5"(13\*13mm) copper pads.

FIG.1-FORWARD CURRENT DERATING CURVE

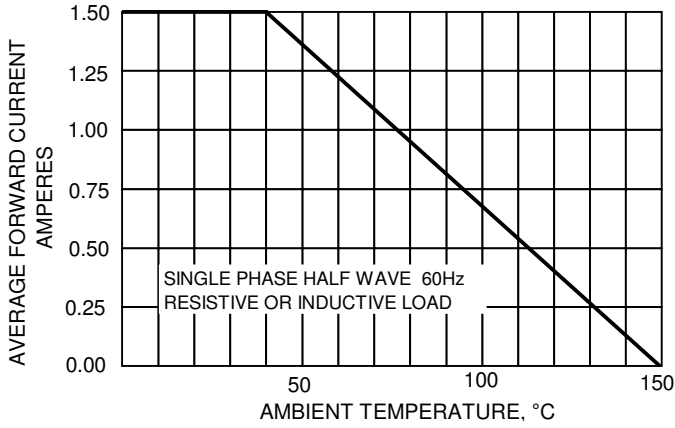

FIG.2-MXIMUM NON-REPETITIVE SURGE CURRENT

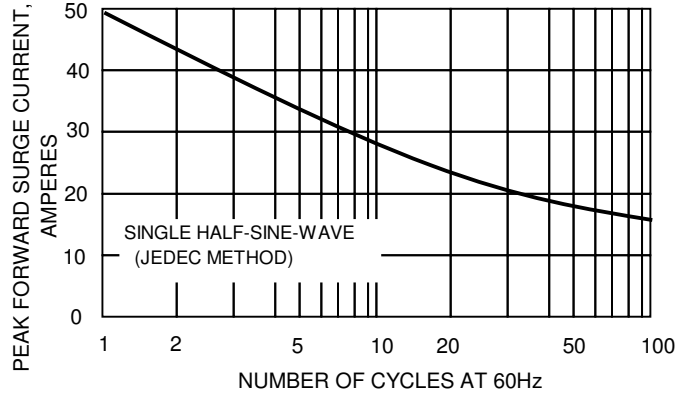

FIG.3-TYPICAL JUNCTION CAPACITANCE

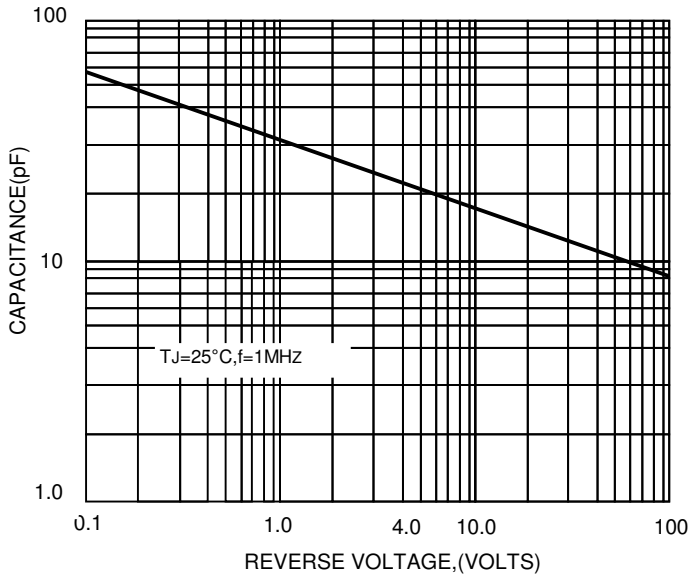

FIG.4-TYPICAL FORWARD CHARACTERISTICS

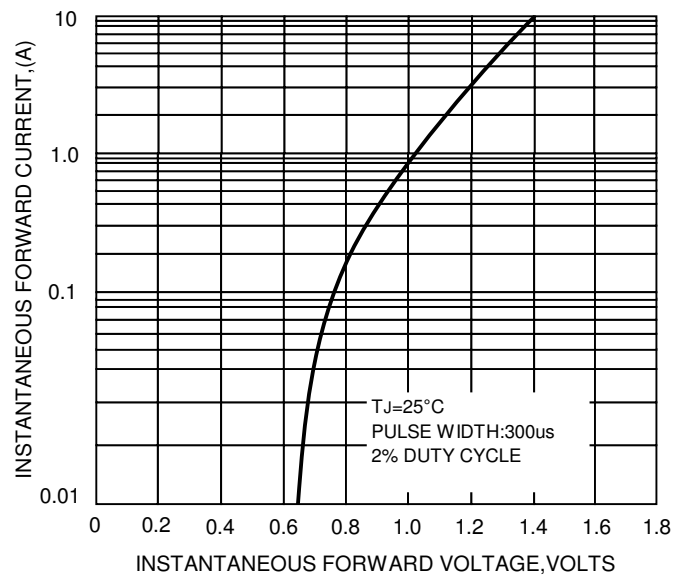

FIG.5-TYPICAL REVERSE CHARACTERISTICS

