

Harvatek Surface Mount LED Data Sheet

HT-P178 Series

Official Product	HT Part No. HT-P178 Series	Your Part No.		Data Sheet No.
Tentative Product	*****	*****		HT-P178 Series
Specifications are subject to changes for improvement without advance notice. Proprietary data, drawings, and company confidential all rights reserved.		Jun. 24, 2011	Version of 1.7	Page 1/26

DISCLAIMER	3
PRODUCT SPECIFICATIONS	4
DESCRIPTION OF PART NUMBER AND LOT NUMBER	6
PACKAGE DIMENSIONS AND RECOMMENDED SOLDERING PATTERN	8
ABSOLUTE MAXIMUM RATINGS	9
ELECTRO-OPTICAL CHARACTERISTICS	10
LUMINOUS FLUX RANK.....	11
DOMINANT WAVELENGTH RANK.....	11
ELECTRICAL RANK.....	12
CORRELATED COLOR TEMPERATURE RANK (FOR WHITE).....	13
CORRELATED COLOR TEMPERATURE AND CHROMATICITY CORRELATION (FOR WHITE)	13
CHARACTERISTICS CURVES.....	14
CHARACTERISTICS CURVES (RED).....	15
CHARACTERISTICS CURVES (YELLOW).....	16
CHARACTERISTICS CURVES (GREEN)	17
CHARACTERISTICS CURVES (BLUE).....	18
CHARACTERISTICS CURVES (WHITE).....	19
TUBE AND PACKING.....	21
TUBE DIMENSION	21
PACKING MODEL.....	21
PRECAUTIONS	22
REFLOW SOLDERING	錯誤! 尚未定義書籤。
REWORKING	24
CLEANING	24
STORAGE.....	24
RELIABILITY TEST	25
REVISION HISTORY	26

Official Product	HT Part No. HT-P178 Series	Your Part No.		Data Sheet No.
Tentative Product	*****	*****		HT-P178 Series
Specifications are subject to changes for improvement without advance notice. Proprietary data, drawings, and company confidential all rights reserved.		Jun. 24, 2011	Version of 1.7	Page 2/26

Disclaimer

HARVATEK reserves the right to make changes without further notice to any products herein to improve reliability, function or design. HARVATEK does not assume any liability arising out of the application or use of any product or circuit described herein; neither does it convey any license under its patent rights, nor the rights of others.

Life Support Policy

HARVATEK's products are not authorized for use as critical components in life support devices or systems without the express written approval of the President of HARVATEK or HARVATEK INTERNATIONAL. As used herein:

1. Life support devices or systems are devices or systems which, (a) are intended for surgical implant into the body, or (b) support or sustain life, and (c) whose failure to perform when properly used in accordance with instructions for use provided in the labeling, can be reasonably expected to result in a significant injury of the user.

2. A critical component in any component of a life support device or system whose failure to perform can be reasonably expected to cause the failure of the life support device or system, or to affect its safety or effectiveness.

Official Product	HT Part No. HT-P178 Series	Your Part No.		Data Sheet No.
Tentative Product	*****	*****		HT-P178 Series
Specifications are subject to changes for improvement without advance notice. Proprietary data, drawings, and company confidential all rights reserved.		Jun. 24, 2011	Version of 1.7	Page 3/26

Product Specifications

	Specification	Material	Quantity
Total Flux	Red: 30lm typical @300mA/ Ta= 25°C, ± 10% Yellow: 30lm typical @300mA/ Ta= 25°C, ± 10% Green: 60lm typical @350mA/ Ta= 25°C, ± 10% Blue: 20lm typical @350mA/ Ta= 25°C, ± 10% White: 90lm typical @350mA/ Ta= 25°C, ± 10%		
Dominant Wavelength	Red: 625nm typical @300mA/ Ta= 25°C, ± 0.5nm Yellow: 592nm typical @300mA/ Ta= 25°C, ± 0.5nm Green: 525nm typical @350mA/ Ta= 25°C, ± 0.5nm Blue: 470nm typical @350mA/ Ta= 25°C, ± 0.5nm		
Correlated Color Temperature	White: 3000K~9000K @350mA/ Ta=25°C, ± 5%		
V _F	Green, blue, white: 3.03-3.99V @350mA/ Ta=25°C, ± 0.1 V Red, yellow: 2.07-2.79V @300mA/ Ta=25°C, ± 0.1 V		
I _R	HT standard		
Resin	Clear	Silicon resin	
Tube	HT standard	Conductive	50pcs per tube
Label	HT standard	Paper	
Carton	HT standard	Paper	

Official Product	HT Part No. HT-P178 Series	Your Part No.		Data Sheet No.
Tentative Product	*****	*****		HT-P178 Series
Specifications are subject to changes for improvement without advance notice. Proprietary data, drawings, and company confidential all rights reserved.		Jun. 24, 2011	Version of 1.7	Page 4/26

Compliance and Certification

RoHS compliant and IS9002, QS9000 and ISO14001 certified.



ATTENTION: Electric Static Discharge (ESD) protection



The symbol to the left denotes that ESD precaution is needed. ESD protection for GaP and AlGaAs based chips is necessary even though they are relatively safe in the presence of low static-electric discharge. Parts built with AlInGaP, GaN, or/and InGaN based chips are **STATIC SENSITIVE**

devices. ESD precaution must be taken during design and assembly.

If manual work or processing is needed, please ensure the device is adequately protected from ESD during the process.

Official Product	HT Part No. HT-P178 Series	Your Part No.		Data Sheet No.
Tentative Product	*****	*****		HT-P178 Series
Specifications are subject to changes for improvement without advance notice. Proprietary data, drawings, and company confidential all rights reserved.		Jun. 24, 2011	Version of 1.7	Page 5/26

Description of Part Number and Lot Number

Part Number

HT - P 1 7 8 X_A X_B - X_C X_D - X_E X_F

Company	Series Code	Dice / Power	Package Code	Emitter Color	Current Code	Bin Code
HT: Harvatek	P: Power	1: One die	Outline Dimension	USD: Red UY: Yellow NG: Green NB: Blue TW: White	T : 300mA U : 350mA	Brightness Range X _C : Minimum bin X _D : Maximum bin Color Range: X _E : Minimum bin X _F : Maximum bin

Lot Number

1 2 3 4 5 6 7 8 9 10
0 D B A B 3 3 8 D T

Code 1 2	Code 3	Code 4	Code 5	Code 6, 7	Code 8 9 10
	Mfg. Year	Mfg. Month	Mfg. Date	Consecutive number	Special code

Official Product	HT Part No. HT-P178 Series	Your Part No.		Data Sheet No.
Tentative Product	*****	*****		HT-P178 Series
Specifications are subject to changes for improvement without advance notice. Proprietary data, drawings, and company confidential all rights reserved.		Jun. 24, 2011	Version of 1.7	Page 6/26

Internal Tracing Code	A: 2010	1: Jan.	1: A	01~ZZ	000-ZZZ
	B: 2011	2: B		
	9: Sep.		
		A: Oct.	26: Z		
			27: 7		
			28: 8		
			30: 3		
			31: 4		

Orderable Part Number

Orderable Part Number	Color	Brightness Intensity Bin	Color Bin
HT-P178USDT-PPPR-13	Red	23.5-51.7 lm	613.5-645.0 nm
HT-P178USDT-PPPR-23		23.5-51.7 lm	620.5-645.0 nm
HT-P178UYT-PPPR-35	Yellow	23.5-51.7 lm	589.5-597.0 nm
HT-P178UYT-PPPR-34		23.5-51.7 lm	589.5-594.5 nm
HT-P178NBU-PMPP-36	Blue	13.9-30.6 lm	460.0-480.0 nm
HT-P178NBU-PMPP-45		13.9-30.6 lm	465.0-475.0 nm
HT-P178NGU-PRPT-25	True Green	39.8-87.4 lm	515.0-535.0 nm
HT-P178NGU-PRPT-34		39.8-87.4 lm	520.0-530.0 nm
HT-P178TWU-PSPU-HL	Warm White	51.7-113.6 lm	2750-4500 K
HT-P178TWU-PSPU-KL		51.7-113.6 lm	2750-3750 K
HT-P178TWU-PTPU-DG	Pure White	67.2-113.6 lm	4750-6750 K
HT-P178TWU-PTPU-FG		67.2-113.6 lm	4750-5750 K
HT-P178TWU-PTPU-DG		67.2-113.6 lm	4750-6750 K
HT-P178TWU-PTPU-AC	Cold White	67.2-113.6 lm	6750-9500 K
HT-P178TWU-PTPU-BC		67.2-113.6 lm	6750-8500 K
HT-P178TWU-PTPU-AC		67.2-113.6 lm	6750-9500 K

Official Product	HT Part No. HT-P178 Series	Your Part No.		Data Sheet No.
Tentative Product	*****	*****		HT-P178 Series
Specifications are subject to changes for improvement without advance notice. Proprietary data, drawings, and company confidential all rights reserved.		Jun. 24, 2011	Version of 1.7	Page 7/26

Package Dimensions and Recommended Soldering Pattern

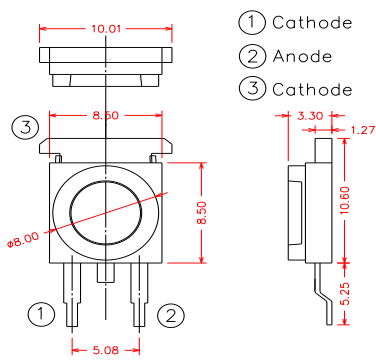
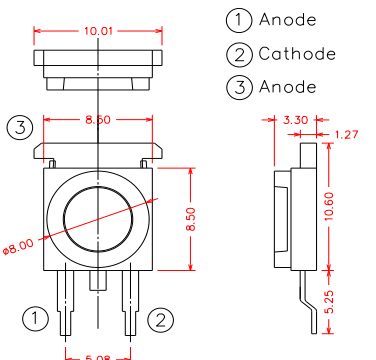
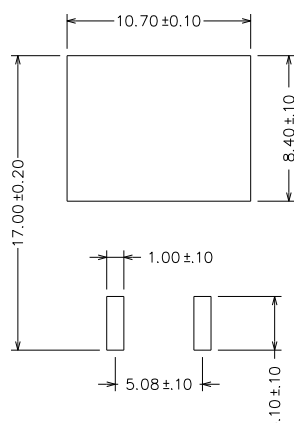
Package Dimensions	Soldering Pattern
<p>Blue, Green, and White</p>  <p>① Cathode ② Anode ③ Cathode</p>	
<p>Red, Yellow</p>  <p>① Anode ② Cathode ③ Anode</p>	 <p>Unit: mm</p>

Tolerance: +/-0.1mm (unless otherwise noted)

Official Product	HT Part No. HT-P178 Series	Your Part No.		Data Sheet No.
Tentative Product	*****	*****		HT-P178 Series
Specifications are subject to changes for improvement without advance notice. Proprietary data, drawings, and company confidential all rights reserved.		Jun. 24, 2011	Version of 1.7	Page 8/26

Absolute Maximum Ratings

Parameter	Red, Yellow	Green, Blue, White	Unit	Conditions ²
DC Forward Current	300	350	mA	-
Peak Pulsed Forward Current ¹	400	500	mA	-
Average Forward Current	300	350	mA	-
Reverse Voltage	5		V	-
LED Junction Temperature	120		°C	-
Operating Temperature	-40 ~ +85		°C	-
Storage Temperature	-40 ~ +120		°C	-
Soldering Temperature	260		°C	5 sec. Max.

¹ $t_p \leq 10\mu s$, Duty cycle=10%

² All at $T_a=25^\circ C$

Official Product	HT Part No. HT-P178 Series	Your Part No.		Data Sheet No.
Tentative Product	*****	*****		HT-P178 Series
Specifications are subject to changes for improvement without advance notice. Proprietary data, drawings, and company confidential all rights reserved.		Jun. 24, 2011	Version of 1.7	Page 9/26

Electro-Optical Characteristics

Parameter	Symbol	Color	Min.	Typ.	Max.	Unit	Condition ³
Forward Voltage	V _F	Green	3.03	-	3.99	V	I _F =350mA
		Blue	3.03	-	3.99	V	
		White	3.03	-	3.99	V	
		Red	2.07	-	2.79	V	I _F =300mA
		Yellow	2.07	-	2.79	V	
Color	λ _D	Green	510	-	550	nm	I _F =350mA
	λ _D	Blue	450	-	490	nm	
	CCT	White	3000	-	9000	K	
	λ _D	Red	613.5	-	645	nm	I _F =300mA
	λ _D	Yellow	584.5	-	597	nm	
Total Flux	Φ _v	Green	-	60	-	lm	I _F =350mA
		Blue	-	20	-	lm	
		White	-	90	-	lm	
		Red	-	30	-	lm	I _F =300mA
		Yellow	-	30	-	lm	
View Angle	2θ ^{1/2}		-	110	-	°	-
Temperature Coefficient of Forward Voltage	ΔV _F /ΔT	Green	-	-2	-	mV/°C	-
		Blue					
		White					
		Red					
		Yellow					
Thermal Resistance Junction to Board	Rθ _{J-B}	Red	-	11	-	°C/W	I _F =300mA
		Yellow					
		Green	-	10	-	I _F =350mA	
		Blue					
		White					

³ All at Ta=25°C

λ_D represents Dominant Wavelength

CCT represents Correlated Color Temperature

Official Product	HT Part No. HT-P178 Series	Your Part No.		Data Sheet No.
Tentative Product	*****	*****		HT-P178 Series
Specifications are subject to changes for improvement without advance notice. Proprietary data, drawings, and company confidential all rights reserved.		Jun. 24, 2011	Version of 1.7	Page 10/26

Luminous Flux Rank (X_C, X_D)

Rank Code	Symbol	Condition	Min.	Typ.	Max.	Unit
PM	ΦV	$I_F=350mA$ (Blue & Green)	13.9	-	18.1	lm
PN			18.1	-	23.5	
PP			23.5	-	30.6	
PQ			30.6	-	39.8	
PR		$I_F=300mA$ (Red & Yellow)	39.8	-	51.7	
PS			51.7	-	67.2	
PT			67.2	-	87.4	
PU			87.4	-	113.6	

Tolerance: $\pm 10\%$

Dominant Wavelength Rank (X_E, X_F)

Red

Rank Code	Symbol	Condition	Min.	Typ.	Max.	Unit
Full	λ_D	$I_F=300mA$	613.5	-	645.0	nm
1			613.5	-	620.5	
2			620.5	-	631.0	
3			631.0	-	645.0	

Yellow

Rank Code	Symbol	Condition	Min.	Typ.	Max.	Unit
Full	λ_D	$I_F=300mA$	584.5	-	597.0	nm
2			587.0	-	589.5	
3			589.5	-	592.0	
4			592.0	-	594.5	
5			594.5	-	597.0	

Blue

Rank Code	Symbol	Condition	Min.	Typ.	Max.	Unit
1	λ_D	$I_F=350mA$	450		455	nm

Official Product	HT Part No. HT-P178 Series	Your Part No.		Data Sheet No.
Tentative Product	*****	*****		HT-P178 Series
Specifications are subject to changes for improvement without advance notice. Proprietary data, drawings, and company confidential all rights reserved.		Jun. 24, 2011	Version of 1.7	Page 11/26

2			455	-	460	
3			460	-	465	
4			465	-	470	
5			470	-	475	
6			475	-	480	
7			480	-	485	
8			485	-	490	

Green

Rank Code	Symbol	Condition	Min.	Typ.	Max.	Unit
1	λ_D	$I_F=350mA$	510		515	nm
2			515	-	520	
3			520	-	525	
4			525	-	530	
5			530	-	535	
6			535	-	540	
7			540	-	545	
8			545	-	550	

Tolerance: $\pm 0.5nm$

Electrical Rank

Rank Code	Symbol	Condition	Min.	Typ.	Max.	Unit
Full	V_F	$I_F=350mA$ (Blue & Green)	2.07	-	2.79	V
P01			2.07	-	2.31	
P02			2.31	-	2.55	
P03			2.55	-	2.79	
P04		$I_F=300mA$ (Red & Yellow)	2.79	-	3.03	
P05			3.03	-	3.27	
P06			3.27	-	3.51	
P07			3.51	-	3.75	
P08			3.75	-	3.99	

Tolerance: $\pm 0.1V$

Official Product	HT Part No. HT-P178 Series	Your Part No.		Data Sheet No.
Tentative Product	*****	*****		HT-P178 Series
Specifications are subject to changes for improvement without advance notice. Proprietary data, drawings, and company confidential all rights reserved.		Jun. 24, 2011	Version of 1.7	Page 12/26

Correlated Color Temperature Rank for White (X_E, X_F)

Color	Condition	Bin Code	Min.	Typ.	Max.
Warm White	I _F =350mA	L1	2,750	3,000	3,250
		L0	2,750	3,000	3,250
		K1	3,250	3,500	3,750
		K0	3,250	3,500	3,750
		J1	3,750	4,000	4,250
		J0	3,750	4,000	4,250
		H1	4,250	4,500	4,750
		H0	4,250	4,500	4,750
Pure White		G1	4,750	5,000	5,250
		G0	4,750	5,000	5,250
		F1	5,250	5,500	5,750
		F0	5,250	5,500	5,750
		E1	5,750	6,000	6,250
		E0	5,750	6,000	6,250
		D1	6,250	6,500	6,750
		D0	6,250	6,500	6,750
Cold White	I _F =350mA	C1	6,750	7,000	7,500
		C0	6,750	7,000	7,500
		B1	7,500	8,000	8,500
		B0	7,500	8,000	8,500
		A	8,500	9,000	9,500

Tolerance: ±5%

Correlated Color Temperature and Chromaticity Correlation (for White)

Official Product	HT Part No. HT-P178 Series	Your Part No.		Data Sheet No.
Tentative Product	*****	*****		HT-P178 Series
Specifications are subject to changes for improvement without advance notice. Proprietary data, drawings, and company confidential all rights reserved.		Jun. 24, 2011	Version of 1.7	Page 13/26

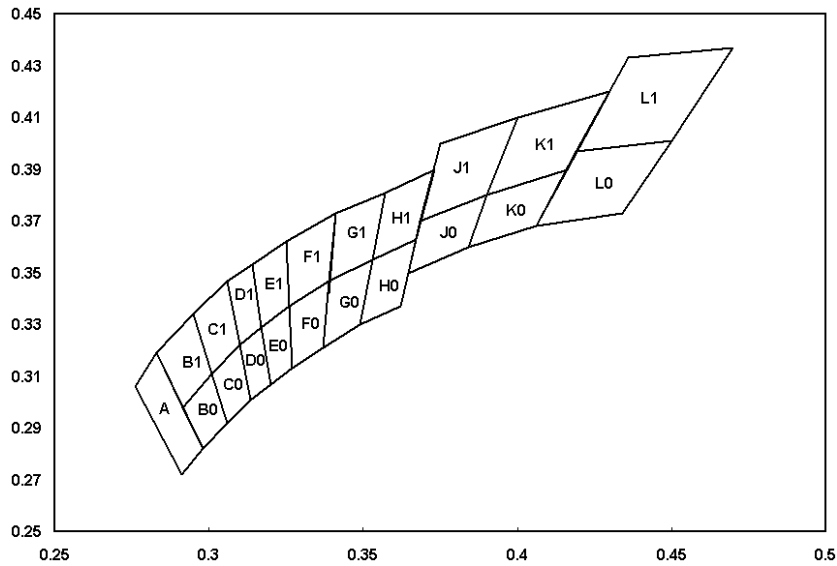

Characteristics Curves

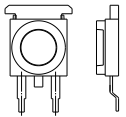

Horizontal

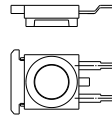

Vertical

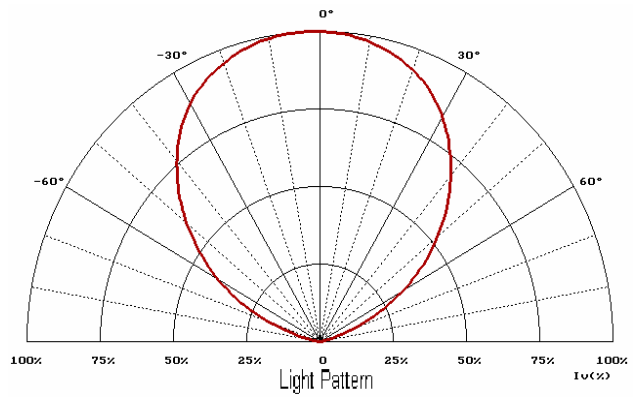
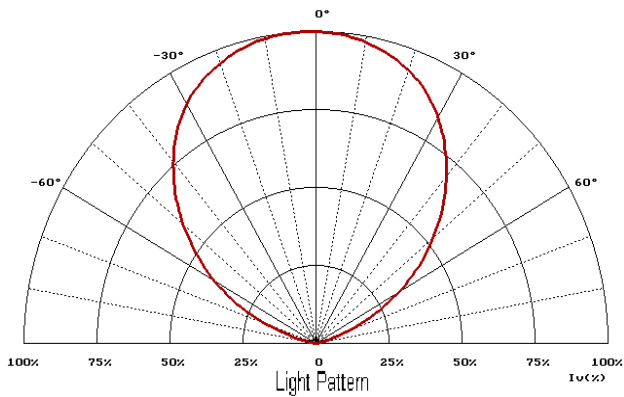

Official Product	HT Part No. HT-P178 Series	Your Part No.	Data Sheet No.
Tentative Product	*****	*****	HT-P178 Series
Specifications are subject to changes for improvement without advance notice. Proprietary data, drawings, and company confidential all rights reserved.		Jun. 24, 2011	Version of 1.7
			Page 14/26

Characteristics Curves (Red)

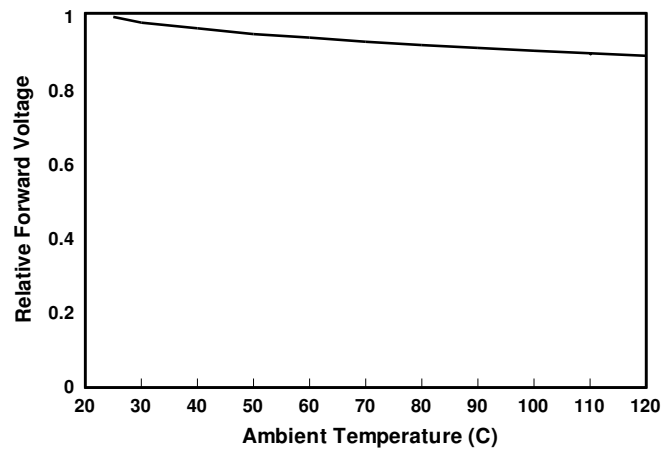
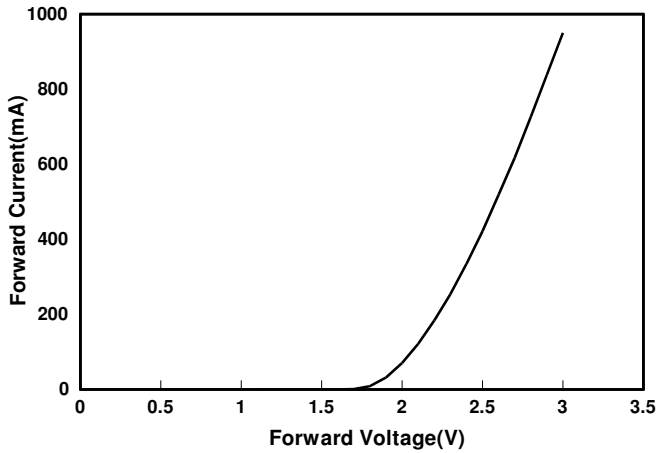
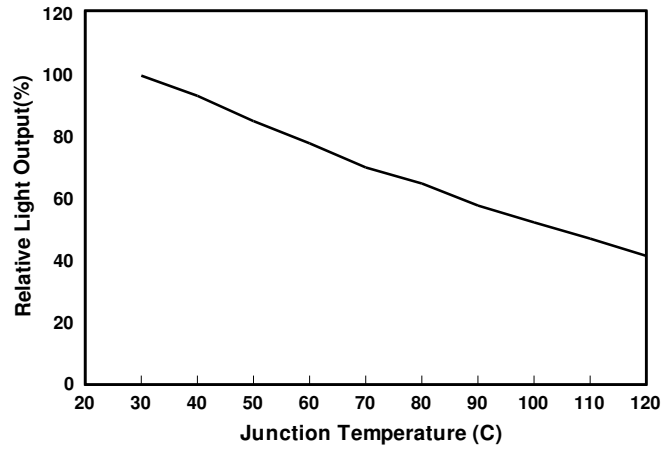
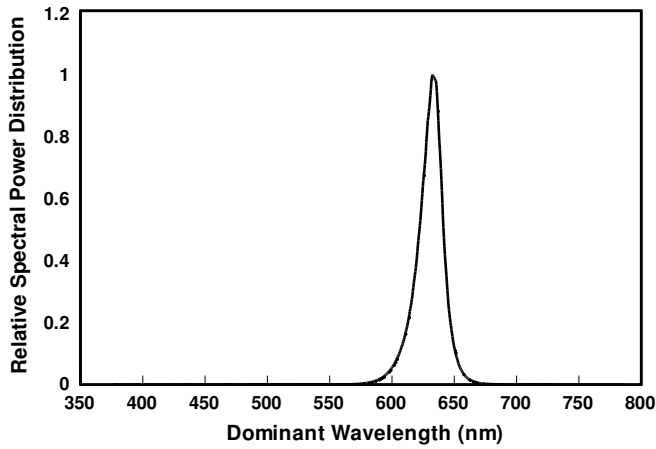

Official Product	HT Part No. HT-P178 Series	Your Part No.		Data Sheet No.
Tentative Product	*****	*****		HT-P178 Series
Specifications are subject to changes for improvement without advance notice. Proprietary data, drawings, and company confidential all rights reserved.		Jun. 24, 2011	Version of 1.7	Page 15/26

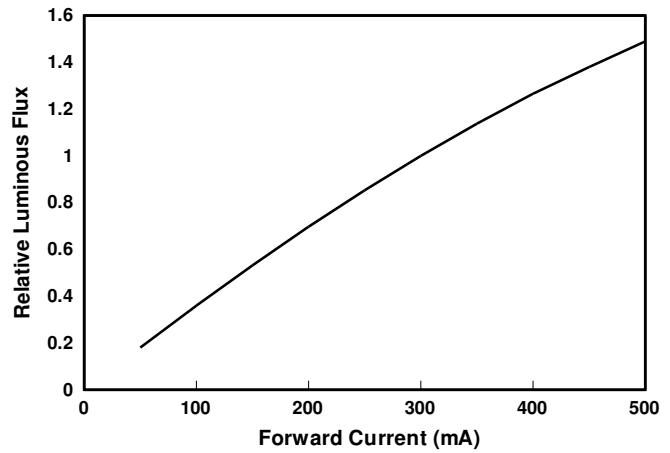
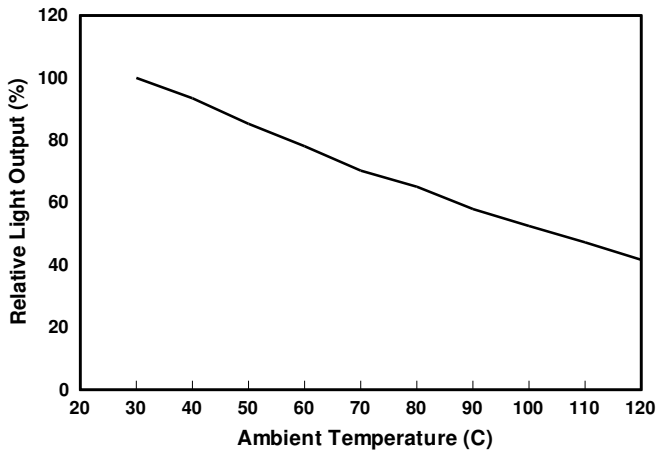

Characteristics Curves (Yellow)

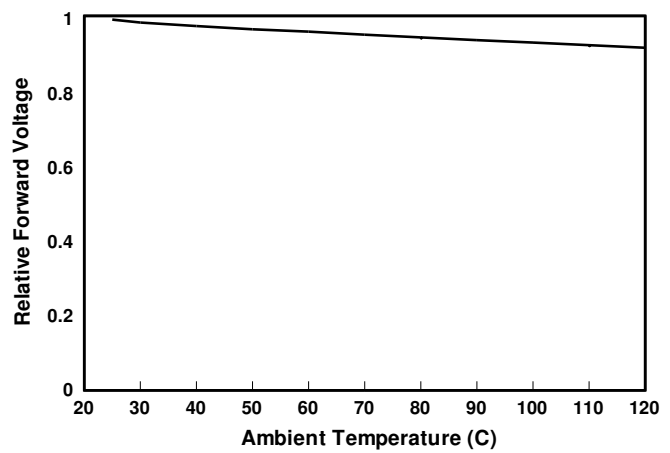
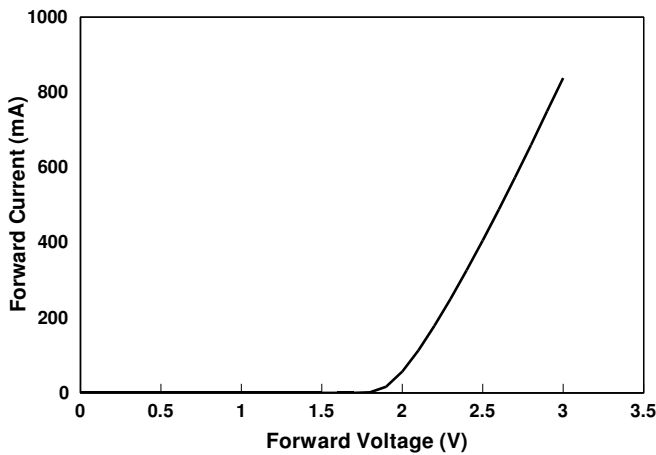
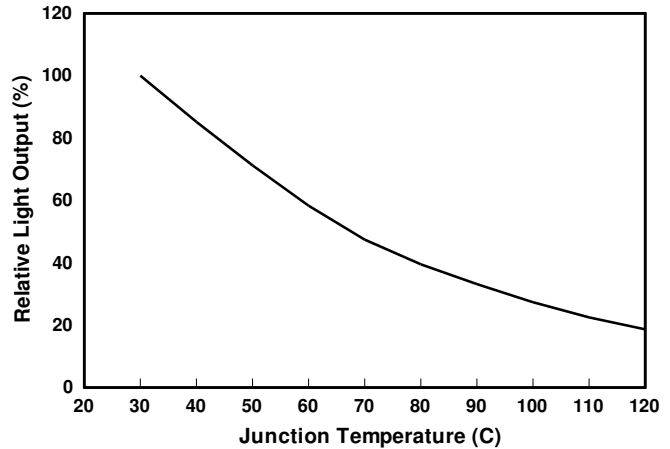
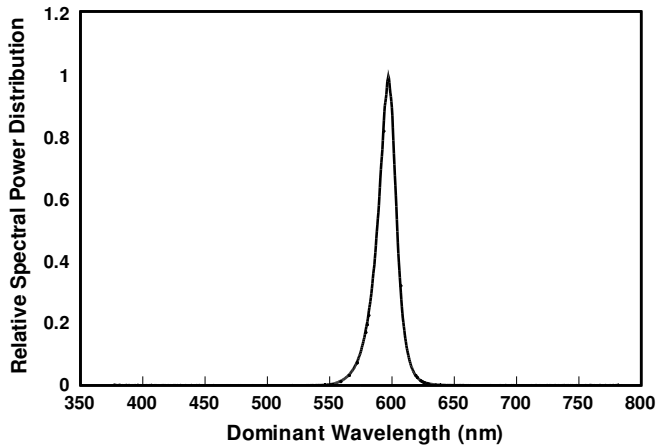

Official Product	HT Part No. HT-P178 Series	Your Part No.	Data Sheet No.
Tentative Product	*****	*****	HT-P178 Series
Specifications are subject to changes for improvement without advance notice. Proprietary data, drawings, and company confidential all rights reserved.		Jun. 24, 2011	Version of 1.7
			Page 16/26

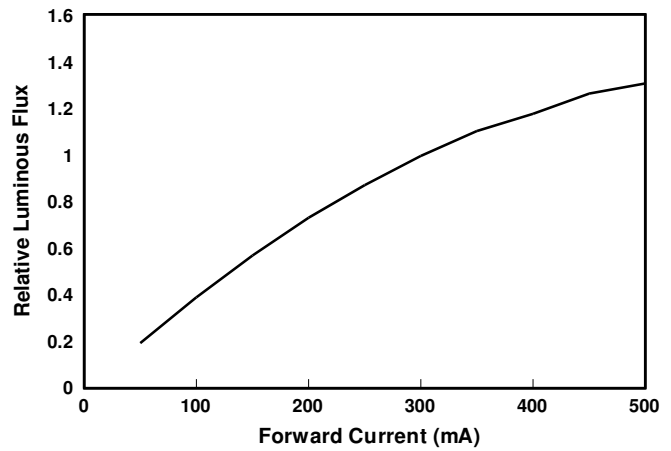
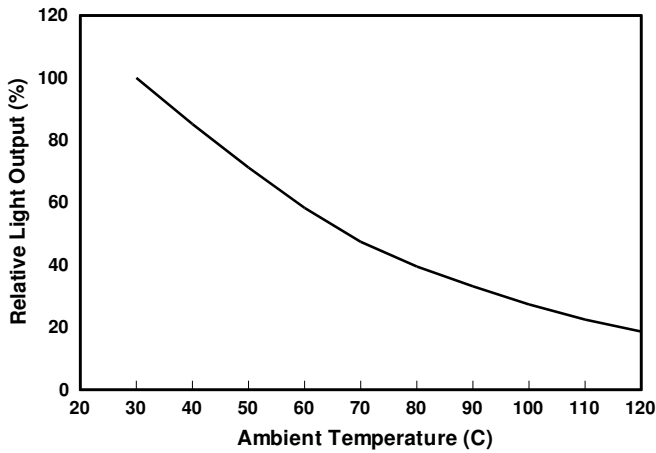

Characteristics Curves (Green)

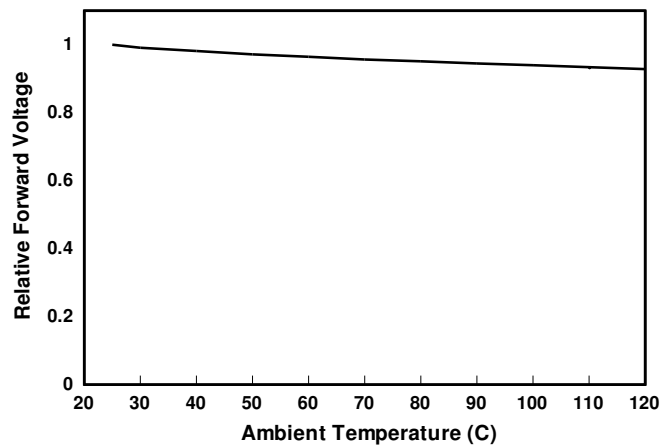
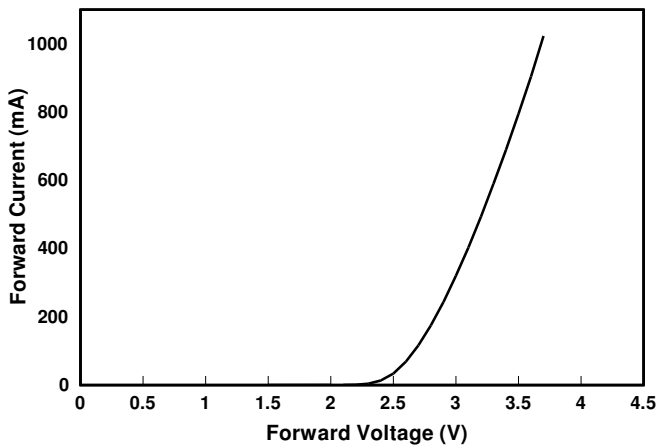
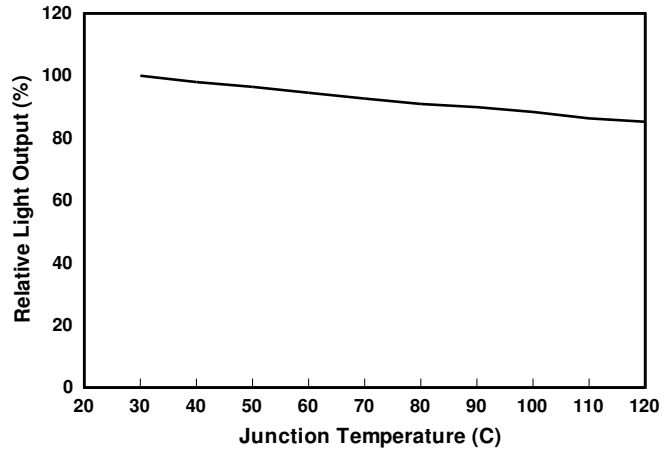
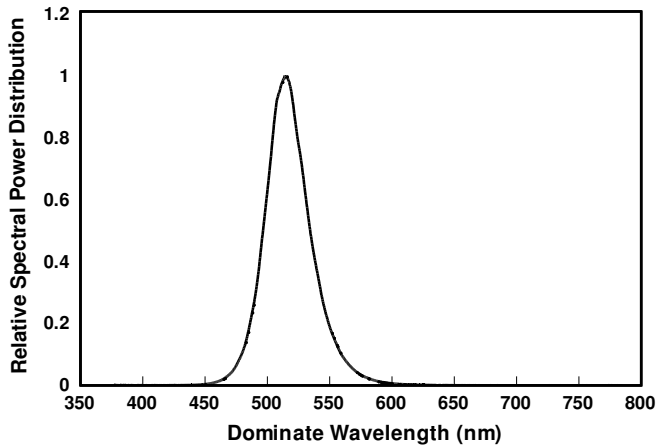

Official Product	HT Part No. HT-P178 Series	Your Part No.	Data Sheet No.
Tentative Product	*****	*****	HT-P178 Series
Specifications are subject to changes for improvement without advance notice. Proprietary data, drawings, and company confidential all rights reserved.		Jun. 24, 2011	Version of 1.7
			Page 17/26

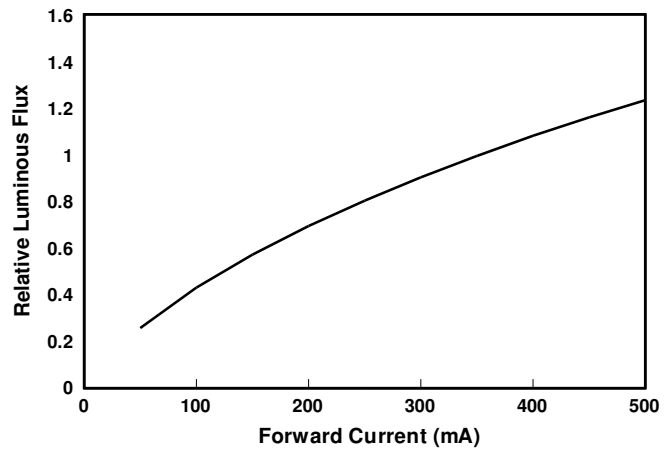
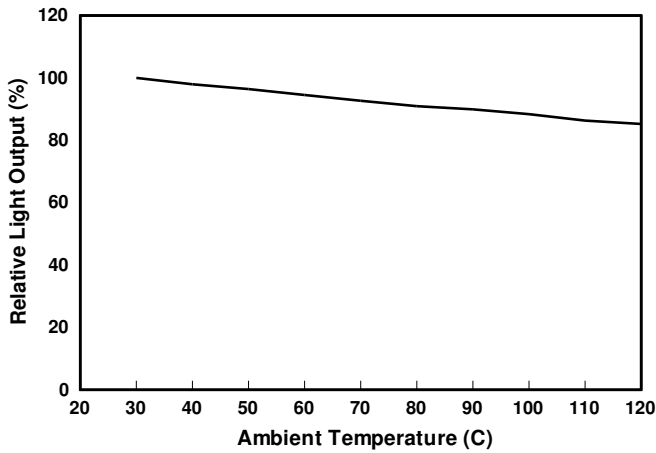

Characteristics Curves (Blue)

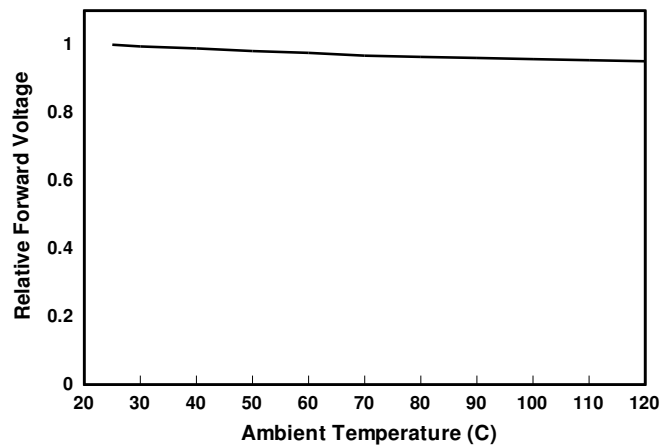
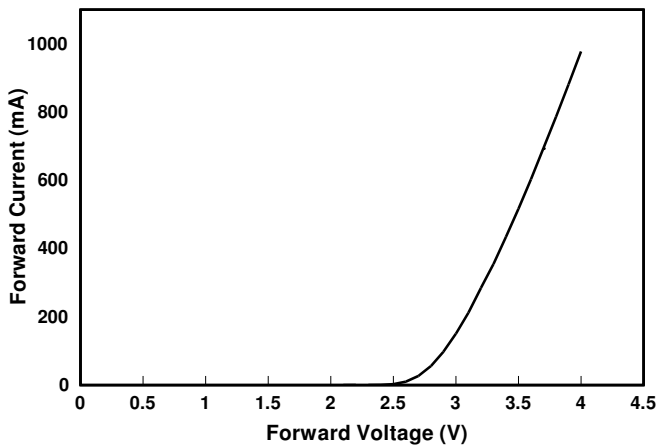
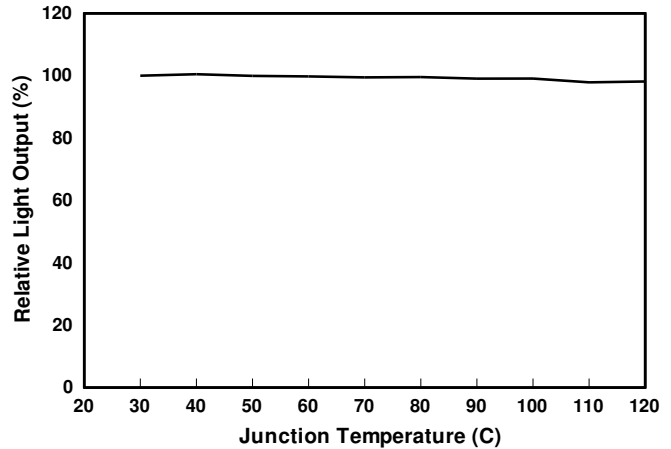
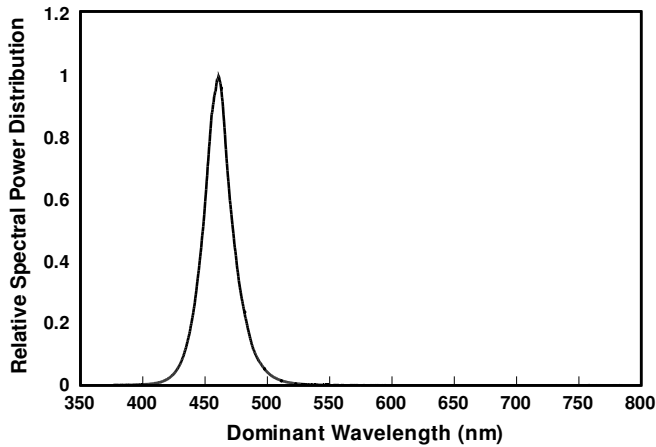

Official Product	HT Part No. HT-P178 Series	Your Part No.	Data Sheet No.
Tentative Product	*****	*****	HT-P178 Series
Specifications are subject to changes for improvement without advance notice. Proprietary data, drawings, and company confidential all rights reserved.		Jun. 24, 2011	Version of 1.7
			Page 18/26

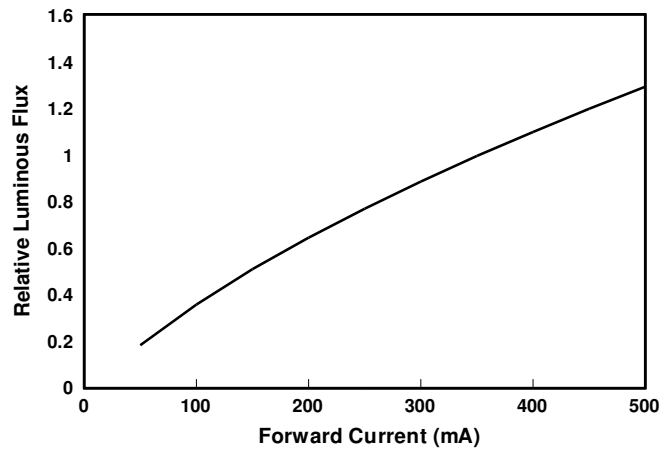
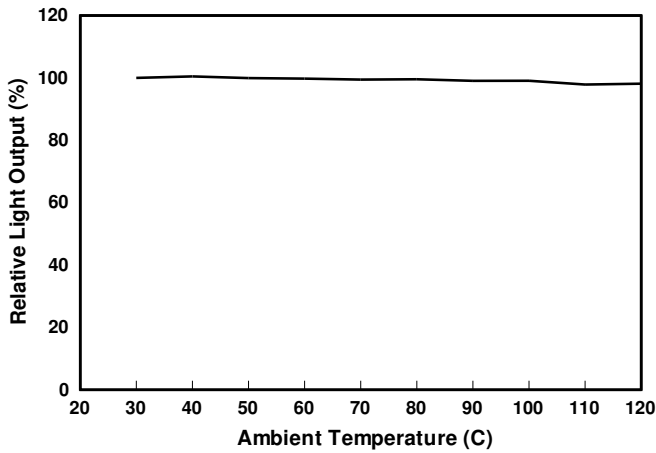

Characteristics Curves (White)

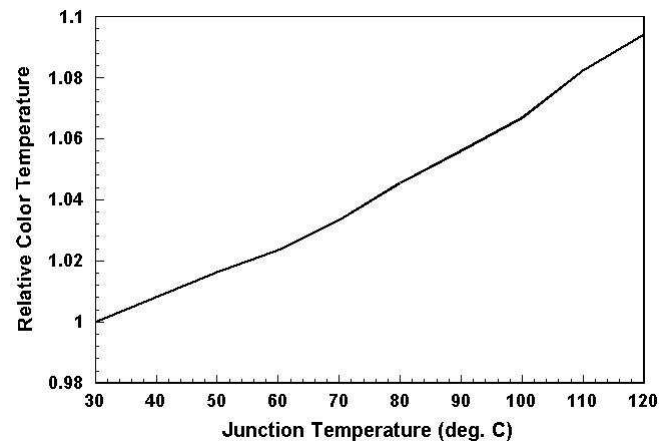
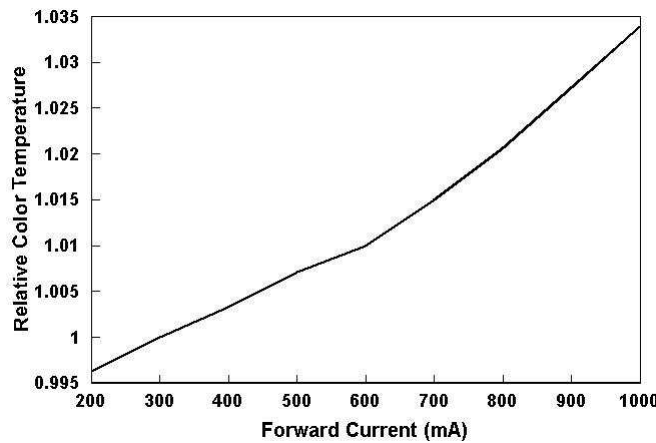
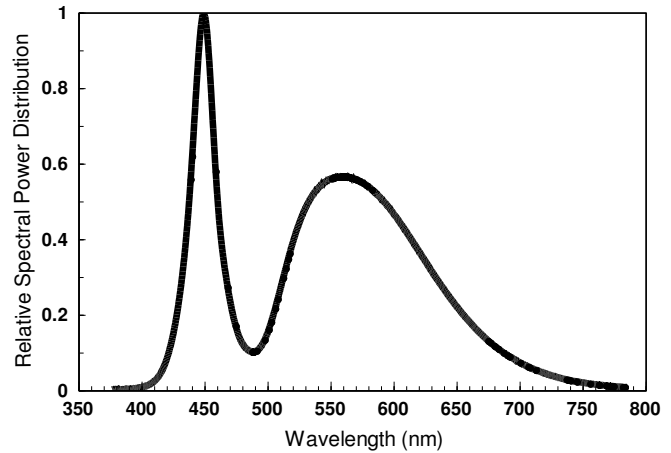
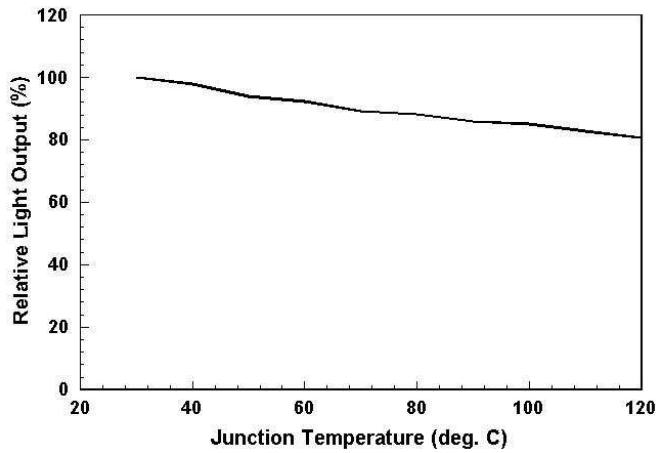

Official Product	HT Part No. HT-P178 Series	Your Part No.		Data Sheet No.
Tentative Product	*****	*****		HT-P178 Series
Specifications are subject to changes for improvement without advance notice. Proprietary data, drawings, and company confidential all rights reserved.		Jun. 24, 2011	Version of 1.7	Page 19/26

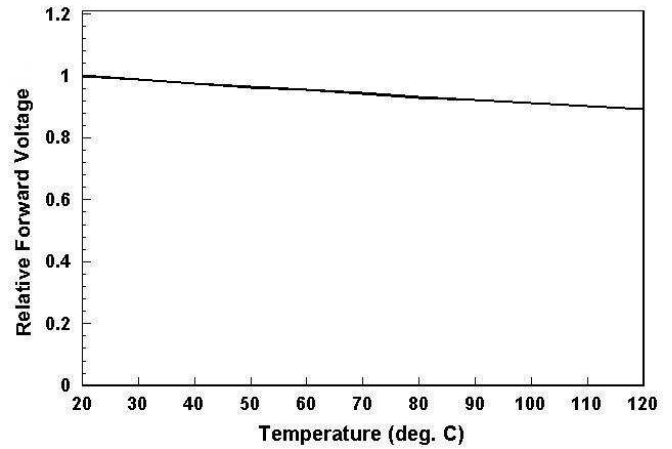
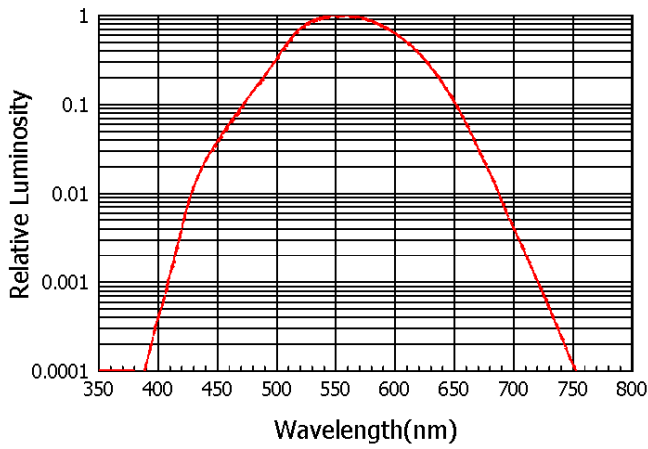
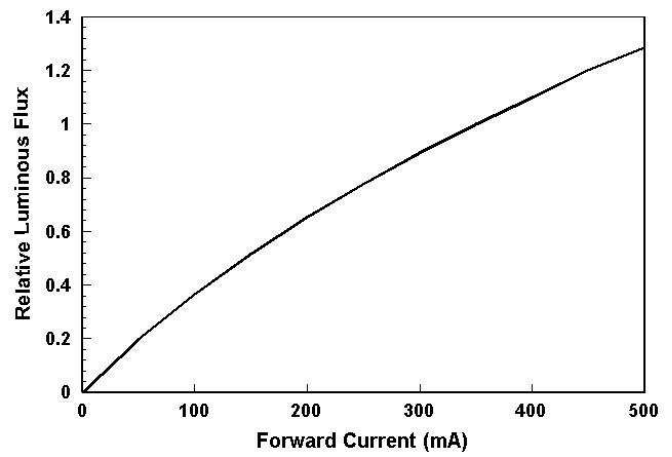
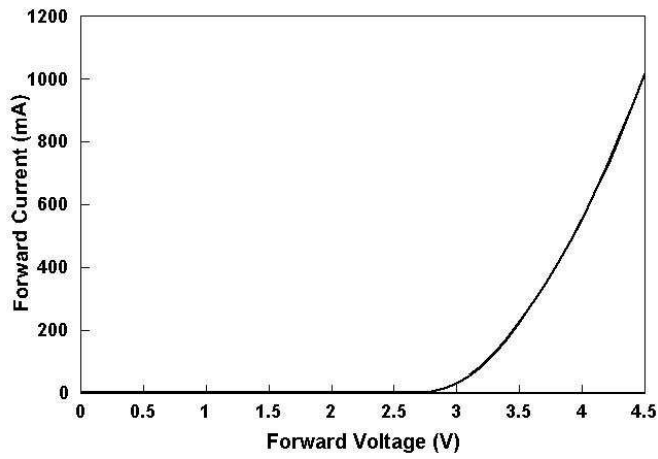

Official Product	HT Part No. HT-P178 Series	Your Part No.		Data Sheet No.
Tentative Product	*****	*****		HT-P178 Series
Specifications are subject to changes for improvement without advance notice. Proprietary data, drawings, and company confidential all rights reserved.		Jun. 24, 2011	Version of 1.7	Page 20/26

Tube and Packing

Tube Dimension

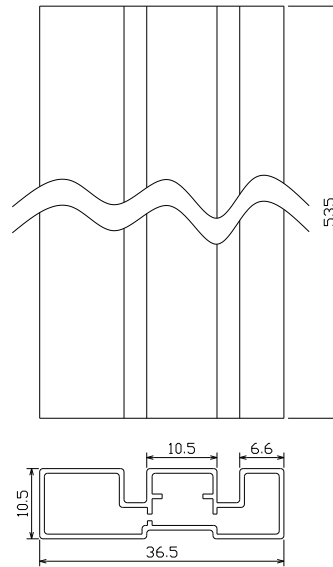
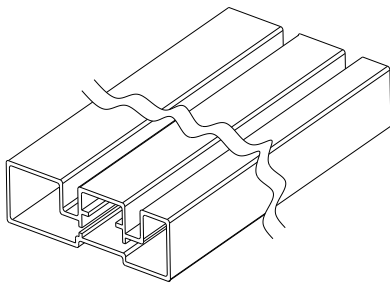

Packing Model

Official Product	HT Part No. HT-P178 Series	Your Part No.		Data Sheet No.
Tentative Product	*****	*****		HT-P178 Series
Specifications are subject to changes for improvement without advance notice. Proprietary data, drawings, and company confidential all rights reserved.		Jun. 24, 2011	Version of 1.7	Page 21/26

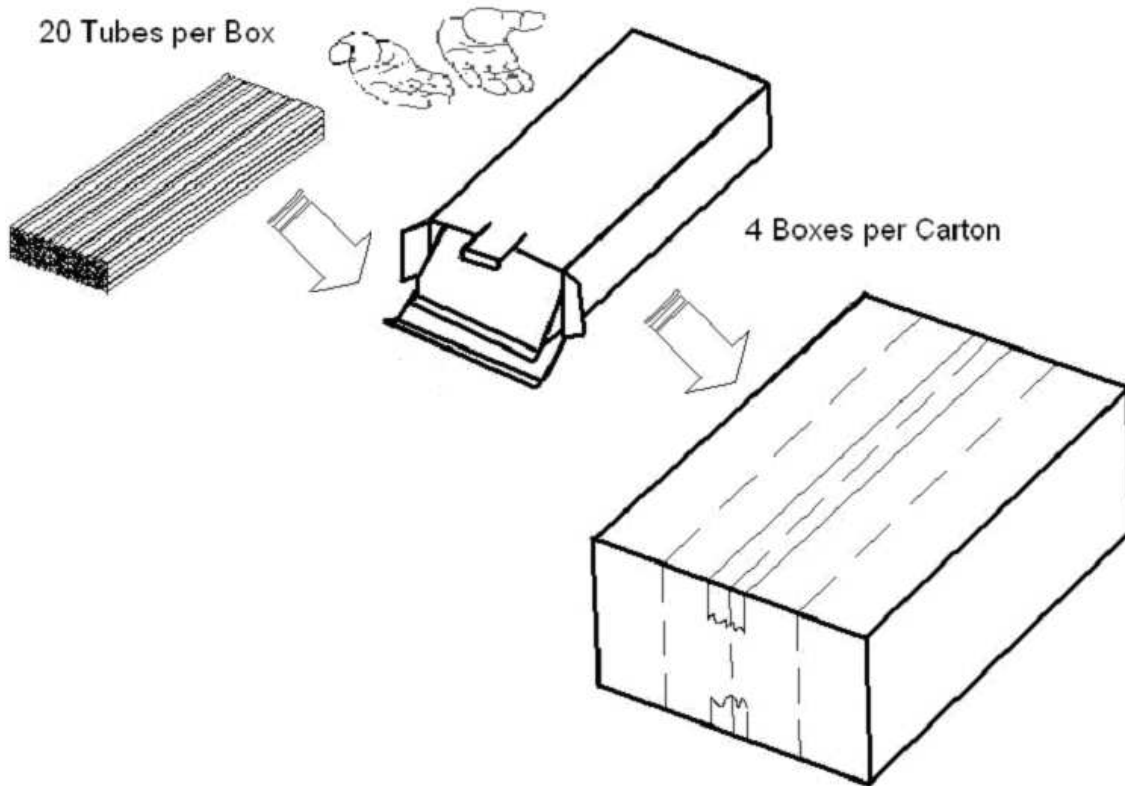

Precautions

1. Avoid exposure to moisture at all times during transportation or storage.
2. Anti-Static precaution must be taken when handling GaN, InGaN, and AlInGaP products.
3. It is suggested to connect the unit with a current limiting resistor of the proper size. Avoid applying a reverse voltage beyond the specified limit.
4. Avoid operation beyond the limits as specified by the absolute maximum ratings.
5. Avoid direct contact with the surface through which the LED emits light.
6. If possible, assemble the unit in a clean room or dust-free environment.

Official Product	HT Part No. HT-P178 Series	Your Part No.		Data Sheet No.
Tentative Product	*****	*****		HT-P178 Series
Specifications are subject to changes for improvement without advance notice. Proprietary data, drawings, and company confidential all rights reserved.		Jun. 24, 2011	Version of 1.7	Page 22/26

Reflow Soldering

1. Recommend soldering paste specifications:
2. Operating temp.: Above 220 °C ,60sec
3. Peak temp.:260 °CMax.,10sec Max.
4. Never take next process until the component is cooled down to room temperature after reflow.
5. The recommended reflow soldering profile (measuring on the surface of the LED terminal) is following:

Lead Solder Profile

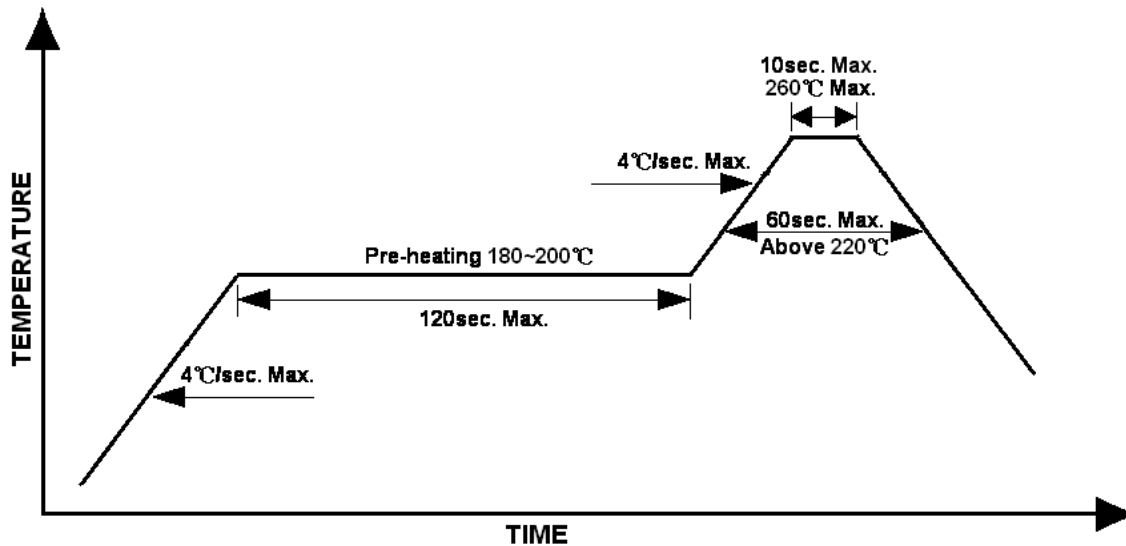

Official Product	HT Part No. HT-P178 Series	Your Part No.		Data Sheet No.
Tentative Product	*****	*****		HT-P178 Series
Specifications are subject to changes for improvement without advance notice. Proprietary data, drawings, and company confidential all rights reserved.		Jun. 24, 2011	Version of 1.7	Page 23/26

Reworking

- Rework should be completed within 5 seconds under 260 °C.
- Manual soldering (not recommended):
Soldering tin material: tin 6/4 alloy or contained Ag.
To prevent cracking, bake before manual soldering.
Temperature of iron tip: 300 °C±5 °C maximum (25W)
Soldering duration: 3sec±1sec

Cleaning

Following are cleaning procedures after soldering:

- An alcohol-based solvent such as isopropyl alcohol (IPA) is recommended.
- Temperature x Time should be 50°C x 30sec. or <30°C x 3min
- Ultra sonic cleaning: < 15W/ bath; bath volume ≤ 1liter
- Curing: 100 °C max, <3min

Cautions of Pick and Place

- Avoid stress on the resin at elevated temperature.
- Avoid rubbing or scraping the resin by any object.
- Electric-static may cause damage to the component. Please ensure that the equipment is properly grounded. Use of an ionizer fan is recommended.

Storage

- It is recommended that products be stored under the following conditions:
Humidity: 60%R.H. maximum
Temperature: 5°C ~ 30°C (41°F ~ 86°F)
- Shelf life in sealed bag: 6 months at <40°C and <90%R.H.
- After opening the bag, devices that will be subjected to soldering or equivalent processing should be used within one year at a condition of ≤30°C / 60%R.H.

Official Product	HT Part No. HT-P178 Series	Your Part No.		Data Sheet No.
Tentative Product	*****	*****		HT-P178 Series
Specifications are subject to changes for improvement without advance notice. Proprietary data, drawings, and company confidential all rights reserved.		Jun. 24, 2011	Version of 1.7	Page 24/26

Reliability Test

Item	Duration	Standards Reference		Conditions	Criteria
		MIL-STD 883 Ref	JIS C 7021 Ref		
High Temperature Operating Life (HTOL)	1000 Hours			55°C, I _F =max DC (Note 1)	Note 2
Room Temperature Operating Life (RTOL)	1000 Hours			25°C, I _F =max DC (Note 1)	Note 2
Low Temperature Operating Life (LTOL)	1000 Hours			-40°C, I _F =max DC	Note 2
Wet High Temperature Operating Life (WHTOL)	1000 Hours		Method B-11, Condition C	85°C/85%RH, I _F =max DC	Note 2
Powered Temperature Cycle (PTMCL)	200 Cycles			-40°C/85°C, 18min dwell, 42min xfer (2 hours cycle), 5min ON/ 5min OFF, I _F =max DC	Note 2
Non Operating Temperature Cycle (TMCL)	200 Cycles	1010	Method A-4	-40°C/120°C, 30min dwell/ 5 min xfer	No Catastrophic
High Temperature Storage Life (HTSL)	1000 Hours	1005	Method B-10	110°C, non operating	Note 2
Low Temperature Storage Life (LTSL)	1000 Hours	1005	Method B-12	-40°C, non operating	Note 2
Non Operating Thermal Shock (TMSK)	200 Cycles			-40°C/110°C, 20min dwell/<20 sec xfer	No Catastrophic
Non Operating Thermal Shock (TMSK)	200 Cycles			-40°C/120°C, 20min dwell/<20 sec xfer	No Catastrophic
Mechanical Shock	5 Shocks	2002	Method A-7 Condition F	1500G, 0.5 sec pulse, 5shocks each 6 axis	No Catastrophic
Natural Drop	3X		Method A-8	On concrete from 1.2m	No Catastrophic
Variable Vibration Frequency		2007	Method A-10 Condition D	10-2000-10 Hz, log or linear sweep rate 20G about 1min, 1.5mm, 3X/axis	No Catastrophic
Variable Vibration Frequency		2007	Method A-10 Condition D	10-55-10 Hz, ±0.75mm, 55-2000, 10G, 1 octave/min, 3X/axis	No Catastrophic
Random Vibration				6G RMS from 10 to 2KHz, 10min/axis	No Catastrophic
Solder Heat Resistance (SHR)				260°C±5°C, 10 sec	No Catastrophic
Solder ability				Steam age for 16hr, then solder dip at 245°C for 5sec	Solder Coverage
Lead Strength				1 lb, 30sec	No Catastrophic
Lead Fatigue				1 lb, 3X45° bend	No Catastrophic
Salt Atmosphere	48 Hours	1009		35°C	No Catastrophic

Note 1: Dependent upon the maximum de-rating curve

Note 2: Failure criteria includes units with catastrophic failure, or units with greater than 50% I_v degradation at 1000 hours, or an average I_v degradation for the test of greater than 35% at 1000 hours

Official Product	HT Part No. HT-P178 Series	Your Part No.		Data Sheet No.
Tentative Product	*****	*****		HT-P178 Series
Specifications are subject to changes for improvement without advance notice. Proprietary data, drawings, and company confidential all rights reserved.		Jun. 24, 2011	Version of 1.7	Page 25/26

Revision History

Changes since last revision	Page	Version No.	Revision Date
New format		1.0	06-13-2005
Remove RGB		1.1	08-01-2005
Update flux for NB	4,8	1.2	10-04-2005
Add RoHS compliance & quality certification and table of orderable part numbers	5	1.3	11-22-2005
Add orderable part number information	7	1.4	05-22-2006
Amend orderable part number information	All	1.5	06-01-2006
Thermal Resistance revision		1.6	11-30-2006
Update flux for P178 series		1.7	06-24-2011

Official Product	HT Part No. HT-P178 Series	Your Part No.		Data Sheet No.
Tentative Product	*****	*****		HT-P178 Series
Specifications are subject to changes for improvement without advance notice. Proprietary data, drawings, and company confidential all rights reserved.		Jun. 24, 2011	Version of 1.7	Page 26/26