

W005M THRU W10M

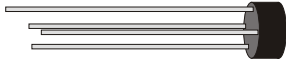

SINGLE PHASE 1.5 AMP BRIDGE RECTIFIERS



FEATURES

- * Ideal for printed circuit board
- * Low forward voltage
- * Low leakage current
- * Polarity: marked on body
- * Mounting position: Any
- * Weight: 1.20 grams

VOLTAGE RANGE

50 to 1000 Volts

CURRENT

1.5 Amperes

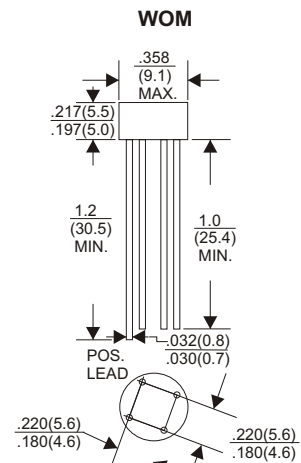

MAXIMUM RATINGS AND ELECTRICAL CHARACTERISTICS

Rating 25°C ambient temperature unless otherwise specified.
Single phase half wave, 60Hz, resistive or inductive load.
For capacitive load, derate current by 20%.

TYPE NUMBER	W005M	W01M	W02M	W04M	W06M	W08M	W10M	UNITS
Maximum Recurrent Peak Reverse Voltage	50	100	200	400	600	800	1000	V
Maximum RMS Voltage	35	70	140	280	420	560	700	V
Maximum DC Blocking Voltage	50	100	200	400	600	800	1000	V
Maximum Average Forward Rectified Current								
.375"(9.5mm) Lead Length at Ta=25°C	1.5							A
Peak Forward Surge Current, 8.3 ms single half sine-wave superimposed on rated load (JEDEC method)	50							A
Maximum Forward Voltage Drop per Bridge Element at 1.0A D.C.	1.0							V
Maximum DC Reverse Current Ta=25°C	10							A
at Rated DC Blocking Voltage Ta=100°C	500							A
Operating Temperature Range, Tj	-65 — +125							°C
Storage Temperature Range, TSTG	-65 — +150							°C

RATING AND CHARACTERISTIC CURVES (W005M THRU W10M)

FIG.1-TYPICAL FORWARD CURRENT DERATING CURVE

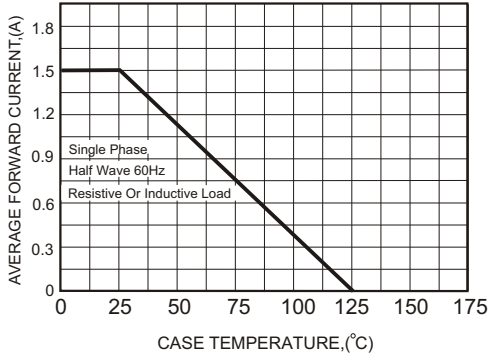

FIG.2-MAXIMUM NON-REPETITIVE FORWARD SURGE CURRENT

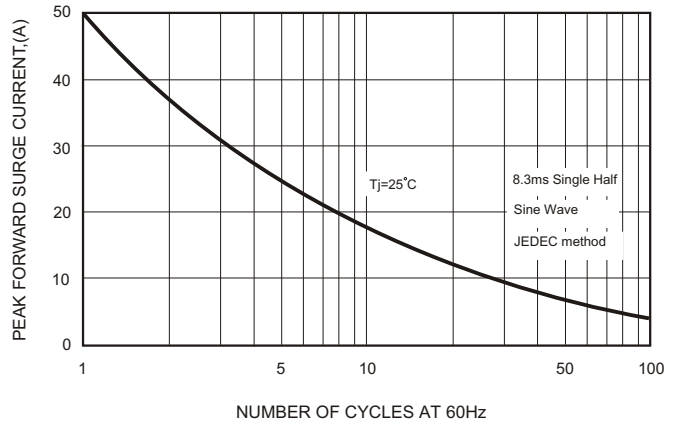

FIG.3-TYPICAL FORWARD CHARACTERISTICS

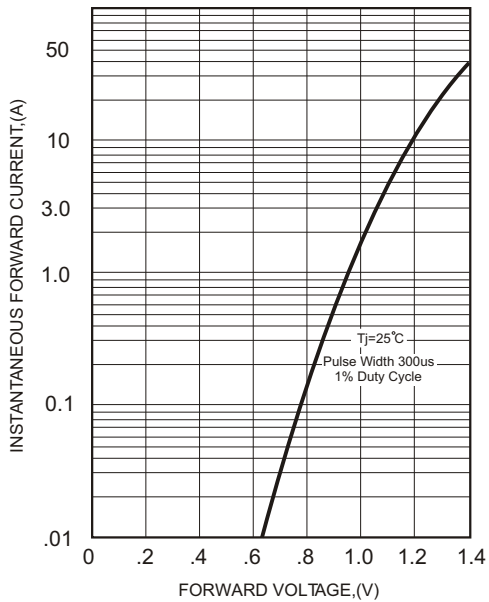

FIG.4-TYPICAL REVERSE CHARACTERISTICS

