

SR1020 THRU SR1060

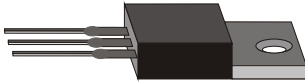

10.0 AMP SCHOTTKY BARRIER RECTIFIERS



FEATURES

- * Low forward voltage drop
- * High current capability
- * High reliability
- * High surge current capability
- * Epitaxial construction

MECHANICAL DATA

- * Case: Molded plastic
- * Epoxy: UL 94V-0 rate flame retardant
- * Lead: Lead solderable per MIL-STD-202, method 208 guaranteed
- * Polarity: As Marked
- * Mounting position: Any
- * Weight: 2.24 grams

VOLTAGE RANGE

20 to 60 Volts

CURRENT

10.0 Amperes

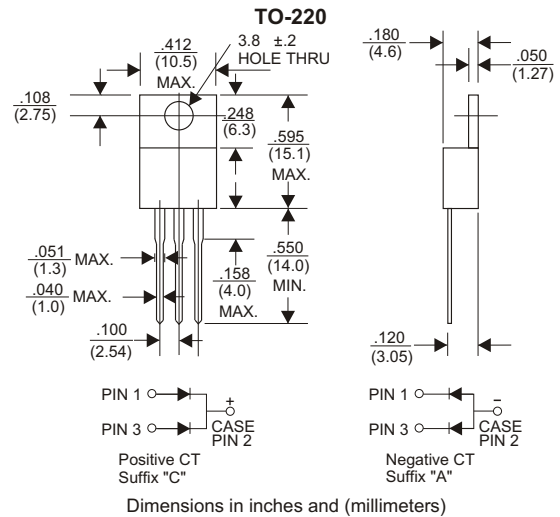

MAXIMUM RATINGS AND ELECTRICAL CHARACTERISTICS

Rating 25°C ambient temperature unless otherwise specified.
Single phase half wave, 60Hz, resistive or inductive load.
For capacitive load, derate current by 20%.

TYPE NUMBER	SR1020	SR1030	SR1035	SR1040	SR1045	SR1050	SR1060	UNITS	
Maximum Recurrent Peak Reverse Voltage	20	30	35	40	45	50	60	V	
Maximum RMS Voltage	14	21	24	28	31	35	42	V	
Maximum DC Blocking Voltage	20	30	35	40	45	50	60	V	
Maximum Average Forward Rectified Current									
See Fig. 1								10	A
Peak Forward Surge Current, 8.3 ms single half sine-wave superimposed on rated load (JEDEC method)								150	A
Maximum Instantaneous Forward Voltage at 5.0A						0.65	0.75	V	
Maximum DC Reverse Current Ta=25°C								10	mA
at Rated DC Blocking Voltage Ta=100°C								100	mA
Typical Junction Capacitance (Note1)						700	460	pF	
Typical Thermal Resistance R _{JC} (Note 2)								3.0	°C/W
Operating Temperature Range T _J						-65 — +125	-65 — +150	°C	
Storage Temperature Range T _{STG}								-65 — +150	°C

NOTES:

1. Measured at 1MHz and applied reverse voltage of 4.0V D.C.
2. Thermal Resistance Junction to Case.

RATING AND CHARACTERISTIC CURVES (SR1020 THRU SR1060)

FIG.1-TYPICAL FORWARD CURRENT DERATING CURVE

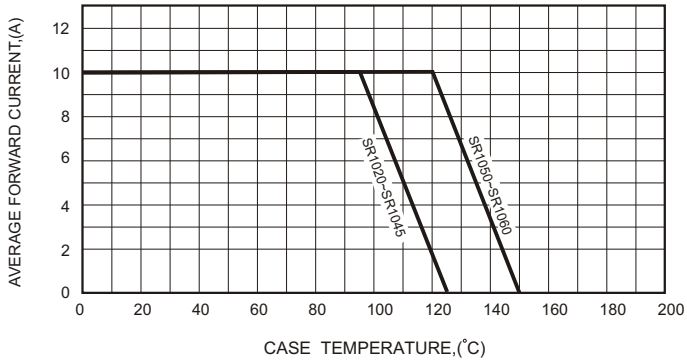

FIG.2-TYPICAL FORWARD CHARACTERISTICS

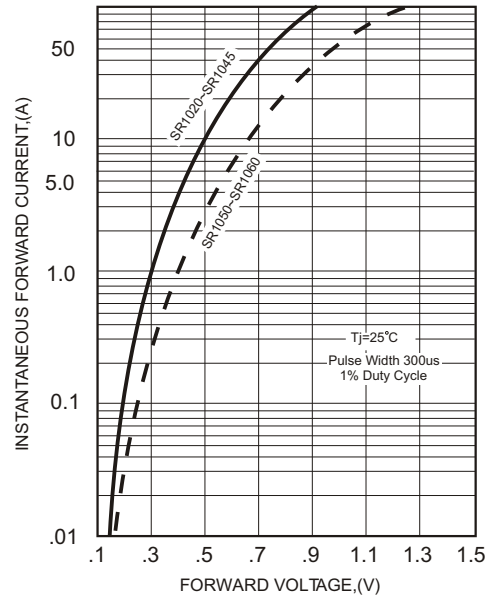

FIG.3-MAXIMUM NON-REPETITIVE FORWARD SURGE CURRENT

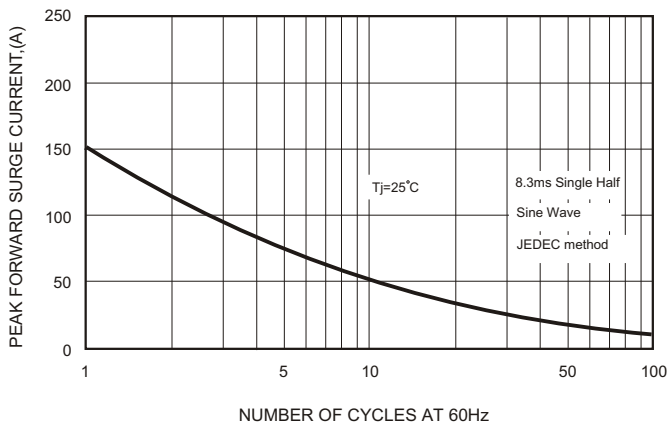

FIG.5 - TYPICAL REVERSE CHARACTERISTICS

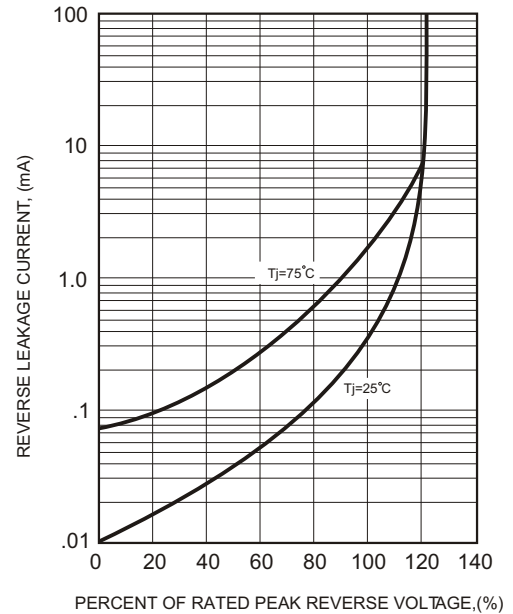

FIG.4-TYPICAL JUNCTION CAPACITANCE

