

Identification

DTM64601C 512Mx64
4GB 2Rx8 PC3-10600S-9-10-F3

Performance range

Clock / Module Speed / CL-t_{RCD} -t_{RP}
667 MHz / DDR3-1333 / 9-9-9
533 MHz / DDR3-1066 / 8-8-8
533 MHz / DDR3-1066 / 7-7-7
400 MHz / DDR3-800 / 6-6-6
333 MHz / DDR3-667 / 5-5-5

Features

204-pin SO-DIMM. Dual-sided assembly 67.60 mm [2.661"] wide by 30.0 mm [1.181"] high

Operating Voltage: 1.5 V ±0.075 V

I/O Type: SSTL_15

Data Transfer Rate: 10.6 Gigabytes/sec

Data Bursts: 8 and burst chop 4 mode

ZQ Calibration for Output Driver and On-Die Termination (ODT)

Programmable ODT / Dynamic ODT during Writes

Programmable CAS Latency: 5, 6, 7, 8, and 9

Differential Data Strobe signals

SDRAM Addressing (Row/Col/Bank): 15/10/3

Fully RoHS Compliant

Description

DTM64601C is a non-ECC Unbuffered DDR3-1333, 512Mx64 memory module. The assembly is comprised of two Ranks. Each Rank is comprised of eight Samsung 256Mx8 DDR3 SDRAMs. One 2K-bit EEPROM is used for Serial Presence Detect.

Both output driver strength and input termination impedance are programmable to maintain signal integrity on the I/O signals.

The assembly is a Small Outline Dual In-line Memory Module intended for mounting into 204-pin edge connector sockets.

Pin Configuration

Pin Description

Front Side				Back Side				Name	Function
1 V _{REFDQ}	53 DQ19	105 V _{DD}	157 DQ42	2 V _{SS}	54 V _{SS}	106 V _{DD}	158 DQ46	DQ[63:0]	Data Bits
3 V _{SS}	55 V _{SS}	107 A10/AP	159 DQ43	4 DQ4	56 DQ28	108 BA1	160 DQ47	DQS[7:0], /DQS[7:0]	Differential Data Strobes
5 DQ0	57 DQ24	109 BA0	161 V _{SS}	6 DQ5	58 DQ29	110 /RAS	162 V _{SS}	DM[7:0]	Data Mask
7 DQ1	59 DQ25	111 V _{DD}	163 DQ48	8 V _{SS}	60 V _{SS}	112 V _{DD}	164 DQ52	CK[1:0], /CK[1:0]	Differential Clock Inputs
9 V _{SS}	61 V _{SS}	113 /WE	165 DQ49	10 /DQS0	62 /DQS3	114 /S0	166 DQ53	CKE[1:0]	Clock Enables
11 DM0	63 DM3	115 /CAS	167 V _{SS}	12 DQS0	64 DQS3	116 ODT0	168 V _{SS}	/CAS	Column Address Strobe
13 V _{SS}	65 V _{SS}	117 V _{DD}	169 /DQS6	14 V _{SS}	66 V _{SS}	118 V _{DD}	170 DM6	/RAS	Row Address Strobe
15 DQ2	67 DQ26	119 A13	171 DQS6	16 DQ6	68 DQ30	120 ODT1	172 V _{SS}	/S[1:0]	Chip Selects
17 DQ3	69 DQ27	121 /S1	173 V _{SS}	18 DQ7	70 DQ31	122 NC	174 DQ54	/WE	Write Enable
19 V _{SS}	71 V _{SS}	123 V _{DD}	175 DQ50	20 V _{SS}	72 V _{SS}	124 V _{DD}	176 DQ55	A[15:0]	Address Inputs
21 DQ8	73 CEK0	125 NC/TEST	177 DQ51	22 DQ12	74 CEK1	126 V _{REFCA}	178 V _{SS}	BA[2:0]	Bank Addresses
23 DQ9	75 V _{DD}	127 V _{SS}	179 V _{SS}	24 DQ13	76 V _{DD}	128 V _{SS}	180 DQ60	ODT[1:0]	On Die Termination Inputs
25 V _{SS}	77 NC	129 DQ32	181 DQ56	26 V _{SS}	78 A15*	130 DQ36	182 DQ61	SA[1:0]	SPD Address
27 /DQS1	79 BA2	131 DQ33	183 DQ57	28 DM1	80 A14	132 DQ37	184 V _{SS}	SCL	SPD Clock Input
29 DQS1	81 V _{DD}	133 V _{SS}	185 V _{SS}	30 /RESET	82 V _{DD}	134 V _{SS}	186 /DQS7	SDA	SPD Data Input/Output
31 V _{SS}	83 A12/BC	135 /DQS4	187 DM7	32 V _{SS}	84 A11	136 DM4	188 DQ57	TEST	Logic Analyzer specific
33 DQ10	85 A9	137 DQS4	189 V _{SS}	34 DQ14	86 A7	138 V _{SS}	190 V _{SS}	V _{SS}	Ground
35 DQ11	87 V _{DD}	139 V _{SS}	191 DQ58	36 DQ15	88 V _{DD}	140 DQ38	192 DQ62	V _{DD}	Power
37 V _{SS}	89 A8	141 DQ34	193 DQ59	38 V _{SS}	90 A6	142 DQ39	194 DQ63	V _{DDSPD}	SPD EEPROM Power
39 DQ16	91 A5	143 DQ35	195 V _{SS}	40 DQ20	92 A4	144 V _{SS}	196 V _{SS}	V _{REFDQ}	Reference Voltage for DQ
41 DQ17	93 V _{DD}	145 V _{SS}	197 SA0	42 DQ21	94 V _{DD}	146 DQ44	198 NC	V _{REFCA}	Reference Voltage for CA
43 V _{SS}	95 A3	147 DQ40	199 V _{DDSPD}	44 V _{SS}	96 A2	148 DQ45	200 SDA	V _{TT}	Termination Voltage
45 /DQS2	97 A1	149 DQ41	201 SA1	46 DM2	98 A0	150 V _{SS}	202 SCL	NC	No Connection
47 DQS2	99 V _{DD}	151 V _{SS}	203 V _{TT}	48 V _{SS}	100 V _{DD}	152 /DQS5	204 V _{TT}		
49 V _{SS}	101 CK0	153 DM5		50 DQ22	102 CK1	154 DQS5			
51 DQ18	103 /CK0	155 V _{SS}		52 DQ23	104 /CK1	156 V _{SS}			

* = Not Used

Front view

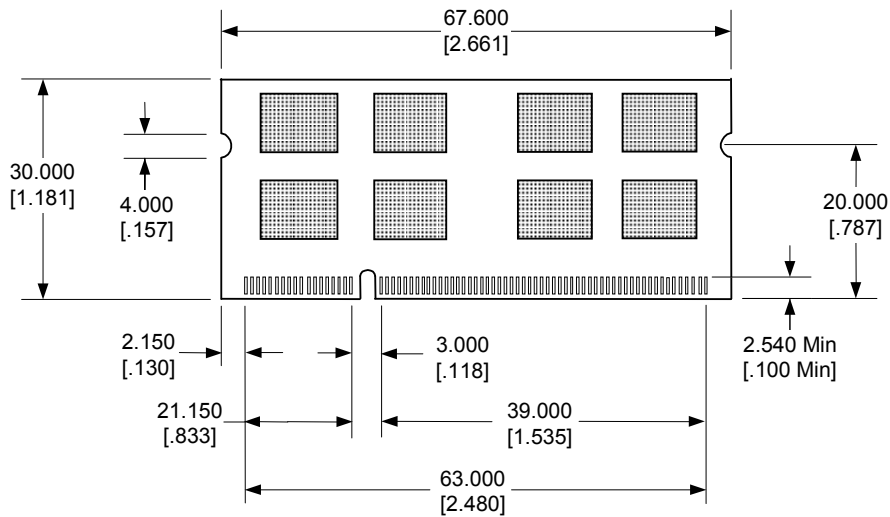

Back view

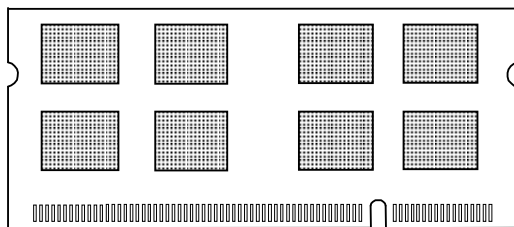

Side view

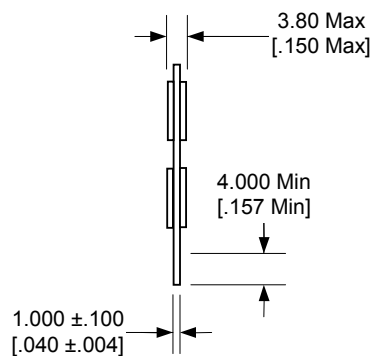

Notes

Tolerances on all dimensions except where otherwise indicated are ± 0.15 (.0059).

All dimensions are expressed: millimeters [inches]

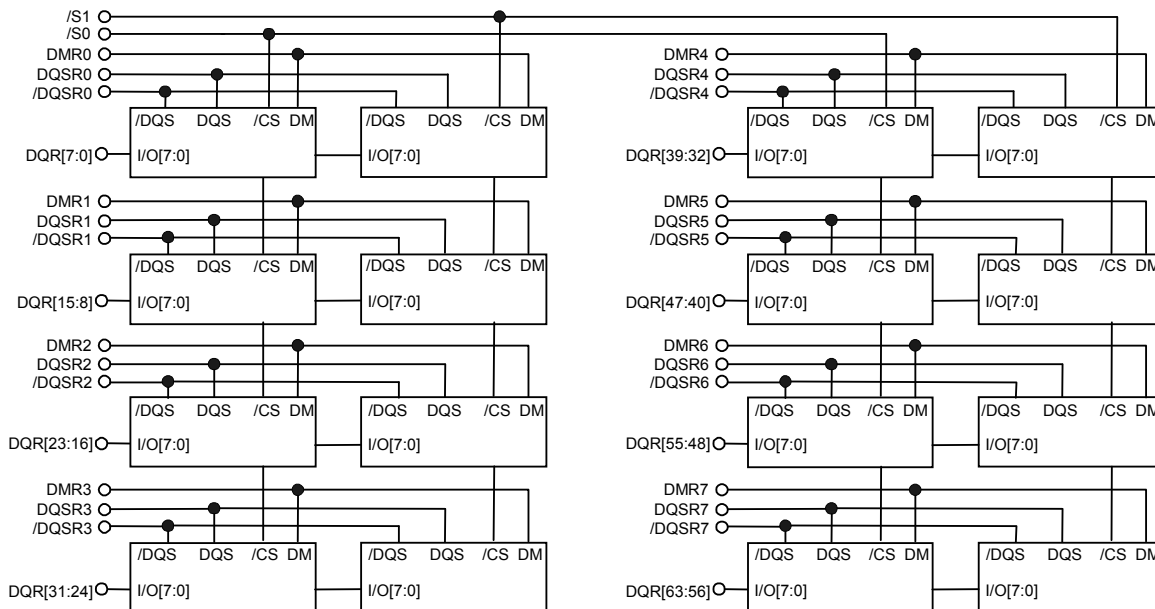

All 15 OHMS

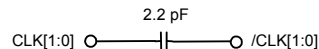
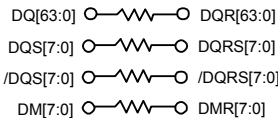

GLOBAL SDRAM CONNECTS

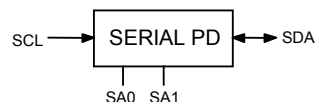
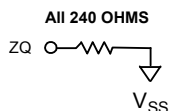
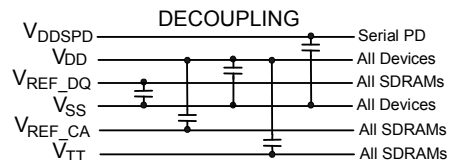
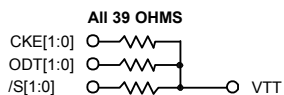
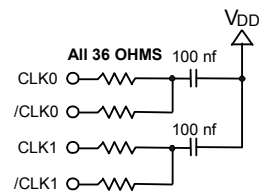
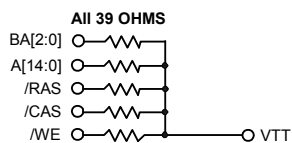



DTM64601C

4GB - 204-pin 2Rx8 Unbuffered Non-ECC DDR3 SO-DIMM

Absolute Maximum Ratings

(Note: Operation at or above Absolute Maximum Ratings can adversely affect module reliability.)

PARAMETER	Symbol	Minimum	Maximum	Unit
Temperature, non-Operating	T _{STORAGE}	-55	100	C
Module Ambient Temperature, Operating	T _A	0	85	C
DRAM Case Temperature, Operating	T _{CASE}	0	95	C
Voltage on V _{DD} relative to V _{SS}	V _{DD}	-0.4	1.975	V
Voltage on Any Pin relative to V _{SS}	V _{IN} , V _{OUT}	-0.4	1.975	V

Notes:

DRAM Operating Case Temperature above 85C requires 2X refresh.

Recommended DC Operating Conditions (T_A = 0 to 70 C, Voltage referenced to V_{SS} = 0 V)

PARAMETER	Symbol	Minimum	Typical	Maximum	Unit	Note
Power Supply Voltage	V _{DD}	1.425	1.5	1.575	V	
I/O Reference Voltage	V _{REFDQ}	0.49 V _{DD}	0.50 V _{DD}	0.51 V _{DD}	V	1
I/O Reference Voltage	V _{REFCA}	0.49 V _{DD}	0.50 V _{DD}	0.51 V _{DD}	V	1

Notes:

The value of V_{REF} is expected to equal one-half V_{DD} and to track variations in the V_{DD} DC level. Peak-to-peak noise on V_{REF} may not exceed ±1% of its DC value. For Reference: V_{DD}/2 ± 15 mV.

DC Input Logic Levels, Single-Ended (T_A = 0 to 70 C, Voltage referenced to V_{SS} = 0 V)

PARAMETER	Symbol	Minimum	Maximum	Unit
Logical High (Logic 1)	V _{IH(DC)}	V _{REF} + 0.1	V _{DD}	V
Logical Low (Logic 0)	V _{IL(DC)}	V _{SS}	V _{REF} - 0.1	V

AC Input Logic Levels, Single-Ended (T_A = 0 to 70 C, Voltage referenced to V_{SS} = 0 V)

PARAMETER	Symbol	Minimum	Maximum	Unit
Logical High (Logic 1)	V _{IH(AC)}	V _{REF} + 0.175	-	V
Logical Low (Logic 0)	V _{IL(AC)}	-	V _{REF} - 0.175	V



DTM64601C

4GB - 204-pin 2Rx8 Unbuffered Non-ECC DDR3 SO-DIMM

Differential Input Logic Levels ($T_A = 0$ to 70 C, Voltage referenced to $V_{SS} = 0$ V)

PARAMETER	Symbol	Minimum	Maximum	Unit	Note
Differential Input Logic High	$V_{IH,DIFF}$	+0.200	DC: V_{DD} AC: $V_{DD}+0.4$	V	1
Differential Input Logic Low	$V_{IL,DIFF}$	DC: V_{SS} AC: $V_{SS}-0.4$	-0.200	V	2
Differential Input Cross Point Voltage relative to $V_{DD}/2$	V_{IX}	- 0.150	+ 0.150	V	4

Capacitance ($T_A = 25$ C, $f = 100$ MHz)

PARAMETER	Pin	Symbol	Minimum	Maximum	Unit
Input Capacitance, Clock	CK[1:0], /CK[1:0]	C_{CK}	6.4	12.8	pF
Input Capacitance, Address	BA[2:0], A[14:0], /RAS, /CAS, /WE	C_I	12	20.8	pF
Input Capacitance Control	/S[1:0], CKE[1:0], ODT[1:0]	C_I	6	10.4	pF
Input/Output Capacitance	DQ[63:0], DQS[7:0], /DQS[7:0], DM[7:0]	C_{IO}	3	5	pF

DC Characteristics ($T_A = 0$ to 70 C, Voltage referenced to $V_{SS} = 0$ V)

PARAMETER	Symbol	Minimum	Maximum	Unit	Note
Input Leakage Current (Any input 0 V < V_{IN} < V_{DD})	I_{IL}	-16	+16	μ A	1,2
Output Leakage Current (0 V < V_{OUT} < V_{DDQ})	I_{OL}	-10	+10	μ A	2,3

Notes:

- 1) All other pins not under test = 0 V
- 2) Values are shown per pin
- 3) DQ's, DQS, DQS and ODT are disabled



DTM64601C

4GB - 204-pin 2Rx8 Unbuffered Non-ECC DDR3 SO-DIMM

I_{DD} Specifications and Conditions (T_A = 0 to 70 C, Voltage referenced to V_{SS} = 0 V)

PARAMETER	Symbol	Test Condition	Max Value	Unit
Operating One Bank Active-Precharge Current	I _{DD0} *	Operating current : One bank ACTIVATE-to-PRECHARGE	480	mA
Operating One Bank Active-Read-Precharge Current	I _{DD1} *	Operating current : One bank ACTIVATE-to-READ-to-PRECHARGE	560	mA
Precharge Power-Down Current	I _{DD2P} **	Precharge power down current: (Slow exit)	192	mA
Precharge Power-Down Current	I _{DD2P} **	Precharge power down current: (Fast exit)	240	mA
Precharge Quiet Standby Current	I _{DD2Q} **	Precharge quiet standby current	320	mA
Precharge Standby Current	I _{DD2N} **	Precharge standby current	320	mA
Active Power-Down Current	I _{DD3P} **	Active power-down current	272	mA
Active Standby Current	I _{DD3N} **	Active standby current	440	mA
Operating Burst Write Current	I _{DD4W} *	Burst write operating current	800	mA
Operating Burst Read Current	I _{DD4R} *	Burst read operating current	760	mA
Burst Refresh Current	I _{DD5} **	Refresh current	1080	mA
Self Refresh Current	I _{DD6} **	Self-refresh temperature current: MAX T _C = 85°C	192	mA
Operating Bank Interleave Read Current	I _{DD7} *	All bank interleaved read current	1240	mA

* One module rank in this operation rest in IDD2P slow exit.

** All module ranks in this operation.



DTM64601C

4GB - 204-pin 2Rx8 Unbuffered Non-ECC DDR3 SO-DIMM

AC Operating Conditions

PARAMETER	Symbol	Min	Max	Unit
Internal read command to first data	t_{AA}	13.125	20	ns
CAS-to-CAS Command Delay	t_{CCD}	4	-	t_{CK}
Clock High Level Width	$t_{CH(avg)}$	0.47	0.53	t_{CK}
Clock Cycle Time	t_{CK}	1.5	2.5	ns
Clock Low Level Width	$t_{CL(avg)}$	0.47	0.53	t_{CK}
Data Input Hold Time after DQS Strobe	t_{DH}	65	-	ps
DQ Input Pulse Width	t_{DIPW}	400	-	ps
DQS Output Access Time from Clock	t_{DQSCK}	-255	+255	ps
Write DQS High Level Width	t_{DQSH}	0.45	0.55	$t_{CK(avg)}$
Write DQS Low Level Width	t_{DQSL}	0.45	0.55	$t_{CK(avg)}$
DQS-Out Edge to Data-Out Edge Skew	t_{DQSQ}	-	125	ps
Data Input Setup Time Before DQS Strobe	t_{DS}	30	-	ps
DQS Falling Edge from Clock, Hold Time	t_{DSH}	0.2	-	$t_{CK(avg)}$
DQS Falling Edge to Clock, Setup Time	t_{DSS}	0.2	-	$t_{CK(avg)}$
Address and Command Hold Time after Clock	t_{IH}	140	-	ps
Address and Command Setup Time before Clock	t_{IS}	65	-	ps
Load Mode Command Cycle Time	t_{MRD}	4	-	t_{CK}
DQ-to-DQS Hold	t_{QH}	0.38	-	$t_{CK(avg)}$
Active-to-Precharge Time	t_{RAS}	36	$9 \cdot t_{REFI}$	ns
Active-to-Active / Auto Refresh Time	t_{RC}	49.125	-	ns
RAS-to-CAS Delay	t_{RCD}	13.125	-	ns
Average Periodic Refresh Interval $0^{\circ} C \leq T_{CASE} < 85^{\circ} C$	t_{REFI}	-	7.8	μs
Average Periodic Refresh Interval $85^{\circ} C \leq T_{CASE} < 95^{\circ} C$	t_{REFI}	-	3.9	μs
Auto Refresh Row Cycle Time	t_{RFC}	160	-	ns
Row Precharge Time	t_{RP}	13.125	-	ns
Read DQS Preamble Time	t_{RPRE}	0.9	Note 1	$t_{CK(avg)}$
Read DQS Postamble Time	t_{RPST}	0.3	Note 2	$t_{CK(avg)}$
Row Active to Row Active Delay	t_{RRD}	Max(4nCK, 6ns)	-	ns
Internal Read to Precharge Command Delay	t_{RTP}	Max(4nCK, 7.5ns)	-	ns
Write DQS Preamble Setup Time	t_{WPRE}	0.9	-	$t_{CK(avg)}$
Write DQS Postamble Time	t_{WPST}	0.3	-	$t_{CK(avg)}$
Write Recovery Time	t_{WR}	15	-	ns
Internal Write to Read Command Delay	t_{WTR}	Max(4nCK, 7.5ns)	-	ns

Notes:

1. The maximum preamble is bound by $t_{LZDQS}(\min)$
2. The maximum postamble is bound by $t_{HZDQS}(\max)$

SERIAL PRESENCE DETECT MATRIX

Byte#	Function.	Value	Hex
0	Number of Bytes Used / Number of Bytes in SPD Device / CRC Coverage.		0x92
	Bit 3 ~ Bit 0. SPD Bytes Used -	176	
	Bit 6 ~ Bit 4. SPD Bytes Total -	256	
	Bit 7. CRC Coverage -	Bytes 0-116	
1	SPD Revision.	Rev. 1.1	0x11
2	Key Byte / DRAM Device Type.	DDR3 SDRAM	0x0B
3	Key Byte / Module Type.		0x03
	Bit 3 ~ Bit 0. Module Type -	SO-DIMM	
	Bit 7 ~ Bit 4. Reserved -	0	
4	SDRAM Density and Banks.		0x03
	Bit 3 ~ Bit 0. Total SDRAM capacity, in megabits -	2Gb	
	Bit 6 ~ Bit 4. Bank Address Bits -	8 banks	
	Bit 7. Reserved -	0	
5	SDRAM Addressing.		0x19
	Bit 2 ~ Bit 0. Column Address Bits -	10	
	Bit 5 ~ Bit 3. Row Address Bits -	15	
	Bit 7, 6. Reserved	0	
6	Reserved.		0x00
7	Module Organization.		0x09
	Bit 2 ~ Bit 0. SDRAM Device Width -	8-Bits	
	Bit 5 ~ Bit 3. Number of Ranks -	2-Rank	
	Bit 7, 6. Reserved	0	
8	Module Memory Bus Width.		0x03
	Bit 2 ~ Bit 0. Primary bus width, in bits -	64-Bits	
	Bit 4, Bit 3. Bus width extension, in bits -	0-Bits	
	Bit 7 ~ Bit 5. Reserved -	0	
9	Fine Timebase (FTB) Dividend / Divisor.		0x11
	Bit 3 ~ Bit 0. Fine Timebase (FTB) Divisor	1	
	Bit 7 ~ Bit 4. Fine Timebase (FTB) Dividend	1	
10	Medium Timebase (MTB) Dividend.	1 (MTB = 0.125ns)	0x01
11	Medium Timebase (MTB) Divisor.	8 (MTB = 0.125ns)	0x08
12	SDRAM Minimum Cycle Time (tCKmin).	1.5ns	0x0C
13	Reserved.	UNUSED	0x00
14	CAS Latencies Supported, Least Significant Byte.		0x3E
	Bit 0. CL = 4 -		
	Bit 1. CL = 5 -	X	



DTM64601C

4GB - 204-pin 2Rx8 Unbuffered Non-ECC DDR3 SO-DIMM

		Bit 2. CL = 6 -	X	
		Bit 3. CL = 7 -	X	
		Bit 4. CL = 8 -	X	
		Bit 5. CL = 9 -	X	
		Bit 6. CL = 10 -		
		Bit 7. CL = 11 -		
15	CAS Latencies Supported, Most Significant Byte.			0x00
		Bit 0. CL = 12 -		
		Bit 1. CL = 13 -		
		Bit 2. CL = 14 -		
		Bit 3. CL = 15 -		
		Bit 4. CL = 16 -		
		Bit 5. CL = 17 -		
		Bit 6. CL = 18 -		
		Bit 7. Reserved.		
16	Minimum CAS Latency Time (tAAmin).	13.125ns	0x69	
17	Minimum Write Recovery Time (tWRmin).	15.0ns	0x78	
18	Minimum RAS# to CAS# Delay Time (tRCDmin).	13.125ns	0x69	
19	Minimum Row Active to Row Active Delay Time (tRRDmin).	6.0ns	0x30	
20	Minimum Row Precharge Delay Time (tRPmin).	13.125ns	0x69	
21	Upper Nibbles for tRAS and tRC.			0x11
		Bit 3 ~ Bit 0. tRAS Most Significant Nibble -	1	
		Bit 7 ~ Bit 4. tRC Most Significant Nibble -	1	
22	Minimum Active to Precharge Delay Time (tRASmin), Least Significant Byte.	36.0ns	0x20	
23	Minimum Active to Active/Refresh Delay Time (tRCmin), Least Significant Byte.	49.125ns	0x89	
24	Minimum Refresh Recovery Delay Time (tRFCmin), Least Significant Byte.	160.0ns	0x00	
25	Minimum Refresh Recovery Delay Time (tRFCmin), Most Significant Byte.	160.0ns	0x05	
26	Minimum Internal Write to Read Command Delay Time (tWTRmin).	7.5ns	0x3C	
27	Minimum Internal Read to Precharge Command Delay Time (tRTPmin).	7.5ns	0x3C	
28	Upper Nibble for tFAW.			0x00
		Bit 3 ~ Bit 0. tFAW Most Significant Nibble -	0	
		Bit 7 ~ Bit 4. Reserved -	0	
29	Minimum Four Activate Window Delay Time (tFAWmin), Least Significant Byte.	30.0ns	0xF0	
30	SDRAM Optional Features.			0x83
		Bit 0. RZQ / 6 -	X	
		Bit 1. RZQ / 7 -	X	
		Bit 6 ~ Bit 2. Reserved -		
		Bit 7. DLL-Off Mode Support		



DTM64601C

4GB - 204-pin 2Rx8 Unbuffered Non-ECC DDR3 SO-DIMM

31	SDRAM Drivers Supported.		0x01
	Extended Temperature Range -	X	
	Extended Temperature Refresh Rate -		
	Auto Self Refresh (ASR) -		
	On-die Thermal Sensor (ODTS) Readout -		
	Reserved -		
	Reserved -		
	Reserved -		
32	Module Thermal Sensor.		0x00
	Bit 6 ~ Bit 0. Thermal Sensor Accuracy -	0	
	Bit 7. Thermal Sensor -	No TS	
33	SDRAM Device Type.		0x00
	Bit 6 ~ Bit 0. Non-Standard Device Description -	0	
	Bit 7. SDRAM Device Type -	Std Mono	
34-59	Reserved	UNUSED	0x00
60	Module Nominal Height.		0x0F
	Bit 4 ~ Bit 0. Module Nominal Height max, in mm -	29<h<=30	
	Bit 7 ~ Bit5. Reserved -	0	
61	Module Maximum Thickness.		0x11
	Bit 3 ~ Bit 0. Front, in mm (baseline thickness = 1 mm) -	1<th<=2	
	Bit 7 ~ Bit 4. Back, in mm (baseline thickness = 1 mm) -	1<th<=2	
62	Reference Raw Card Used.		0x65
	Bit 4 ~ Bit 0. Reference Raw Card -	R/C F	
	Bit 6, Bit 5. Reference Raw Card Revision -	Rev.3	
	Bit 7. Reserved -	0	
63	Address Mapping from Edge Connector to DRAM.		0x00
	Bit 0. Rank 1 Mapping (Registered DIMM - Reserved) -	Standard	
	Bit 7 ~ Bit 1. Reserved -	0	
64-112	Module-Specific Section	UNUSED	0x00
113	Module-Specific Section.	UNUSED	0x00
114-116	Module-Specific Section	UNUSED	0x00
117	Module Manufacturer ID Code, Least Significant Byte		0x80
118	Module Manufacturer ID Code, Most Significant Byte		0xCE
119	Module Manufacturing Location		0x02
120	Module Manufacturing Date		0x11
121	Module Manufacturing Date		0x29
122	Module Serial Number	#	0x23
123	Module Serial Number	#	0x23
124	Module Serial Number	#	0x23



DTM64601C

4GB - 204-pin 2Rx8 Unbuffered Non-ECC DDR3 SO-DIMM

125	Module Serial Number	#	0x23
126	Cyclical Redundancy Code (CRC).	CRC	0x7B
127	Cyclical Redundancy Code (CRC).	CRC	0xFC
128	Module Part Number	M	0x4D
129	Module Part Number	4	0x34
130	Module Part Number	7	0x37
131	Module Part Number	1	0x31
132	Module Part Number	B	0x42
133	Module Part Number	5	0x35
134	Module Part Number	2	0x32
135	Module Part Number	7	0x37
136	Module Part Number	3	0x33
137	Module Part Number	D	0x44
138	Module Part Number	H	0x48
139	Module Part Number	0	0x30
140	Module Part Number	-	0x2D
141	Module Part Number	C	0x43
142	Module Part Number	H	0x48
143	Module Part Number	9	0x39
144,145	Module Part Number		0x20
146,147	Module Revision Code	UNUSED	0x00
148	DRAM Manufacturer ID Code, Least Significant Byte		0x80
149	DRAM Manufacturer ID Code, Most Significant Byte		0xCE
150-175	Manufacturer's Specific Data		0x00
176-255	Open for customer use		0x00



DTM64601C

4GB - 204-pin 2Rx8 Unbuffered Non-ECC DDR3 SO-DIMM



DATARAM CORPORATION, USA Corporate Headquarters, P.O. Box 7528, Princeton, NJ 08543-7528;
Voice: 609-799-0071, Fax: 609-799-6734; www.dataram.com

All rights reserved.

The information contained in this document has been carefully checked and is believed to be reliable. However, Dataram assumes no responsibility for inaccuracies.

The information contained in this document does not convey any license under the copyrights, patent rights or trademarks claimed and owned by Dataram.

No part of this publication may be copied or reproduced in any form or by any means, or transferred to any third party without prior written consent of Dataram.