

DTM64384A

8GB - 240-Pin 2Rx8 Unbuffered Non-ECC DDR3 DIMM

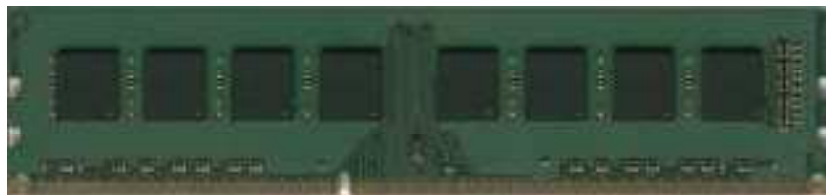

Identification

DTM64384A 1Gx64
8GB 2Rx8 PC3-10600U-9-11-B1

Performance range

Clock / Module Speed / CL-t_{RC}D -t_{RP}
667 MHz / PC3-10600 / 9-9-9
533 MHz / PC3-8500 / 8-8-8
533 MHz / PC3-8500 / 7-7-7
400 MHz / PC3-6400 / 6-6-6

Features

240-pin JEDEC-compliant DIMM, 133.35 mm wide by 30 mm high
Operating Voltage: 1.5 V ±0.075 V
I/O Type: SSTL_15
Data Transfer Rate: 10.6 Gigabytes/sec
Data Bursts: 8 and burst chop 4 mode
ZQ Calibration for Output Driver and On-Die Termination (ODT)
Programmable ODT / Dynamic ODT during Writes
Programmable CAS Latency: 6, 7, 8, and 9
Differential Data Strobe signals
SDRAM Addressing (Row/Col/Bank): 16/10/3
Fully RoHS Compliant

Description

DTM64384A is an Unbuffered 1Gx64 memory module, which conforms to JEDEC's DDR3, PC3-10600 standard. The assembly is Dual-Rank. Each Rank consists of eight 512Mx8 DDR3 Samsung SDRAMs. One 2K-bit EEPROM is used for Serial Presence Detect.

Both output driver strength and input termination impedance are programmable to maintain signal integrity on the I/O signals.

Pin Configuration

Pin Description

Front Side				Back Side				Name	Function
1 V _{REFDQ}	31 DQ25	61 A2	91 DQ41	121 V _{SS}	151 V _{SS}	181 A1	211 V _{SS}	CB[7:0]	Data Check Bits
2 V _{SS}	32 V _{SS}	62 V _{DD}	92 V _{SS}	122 DQ4	152 DM3	182 V _{DD}	212 DM5	DQ[63:0]	Data Bits
3 DQ0	33 /DQS3	63 CK1	93 /DQS5	123 DQ5	153 NC	183 V _{DD}	213 NC	DQS[8:0], /DQS[8:0]	Differential Data Strobes
4 DQ1	34 DQS3	64 /CK1	94 DQS5	124 V _{SS}	154 V _{SS}	184 CK0	214 V _{SS}	DM[8:0]	Data Mask
5 V _{SS}	35 V _{SS}	65 V _{DD}	95 V _{SS}	125 DM0	155 DQ30	185 /CK0	215 DQ46	CK[1:0], /CK[1:0]	Differential Clock Inputs
6 /DQS0	36 DQ26	66 V _{DD}	96 DQ42	126 NC	156 DQ31	186 V _{DD}	216 DQ47	CKE[1:0]	Clock Enables
7 DQS0	37 DQ27	67 V _{REFCA}	97 DQ43	127 V _{SS}	157 V _{SS}	187 NC	217 V _{SS}	/CAS	Column Address Strobe
8 V _{SS}	38 V _{SS}	68 NC	98 V _{SS}	128 DQ6	158 CB4, NC*	188 A0	218 DQ52	/RAS	Row Address Strobe
9 DQ2	39 CB0, NC*	69 VDD	99 DQ48	129 DQ7	159 CB5, NC*	189 V _{DD}	219 DQ53	/S[3:0]	Chip Selects
10 DQ3	40 CB1, NC*	70 A10/AP	100 DQ49	130 V _{SS}	160 V _{SS}	190 BA1	220 V _{SS}	/WE	Write Enable
11 V _{SS}	41 V _{SS}	71 BA0	101 V _{SS}	131 DQ12	161 DM8, NC*	191 V _{DD}	221 DM6	A[15:0]	Address Inputs
12 DQ8	42 /DQS8*	72 V _{DD}	102 /DQS6	132 DQ13	162 NC	192 /RAS	222 NC	BA[2:0]	Bank Addresses
13 DQ9	43 DQS8*	73 /WE	103 DQS6	133 V _{SS}	163 V _{SS}	193 /S0	223 V _{SS}	ODT[1:0]	On Die Termination Inputs
14 V _{SS}	44 V _{SS}	74 /CAS	104 V _{SS}	134 DM1	164 CB6, NC*	194 V _{DD}	224 DQ54	SA[2:0]	SPD Address
15 /DQS1	45 CB2, NC*	75 V _{DD}	105 DQ50	135 NC	165 CB7, NC*	195 ODT0	225 DQ55	SCL	SPD Clock Input
16 DQS1	46 CB3, NC*	76 /S1	106 DQ51	136 V _{SS}	166 V _{SS}	196 A13	226 V _{SS}	SDA	SPD Data Input/Output
17 V _{SS}	47 V _{SS}	77 ODT1	107 V _{SS}	137 DQ14	167 NC (TEST)	197 V _{DD}	227 DQ60	/RESET	Reset pin on DRAMs
18 DQ10	48 V _{TT}	78 V _{DD}	108 DQ56	138 DQ15	168 /RESET	198 /S3, NC*	228 DQ61	A12/BC	Combination input: Addr12/Burst Chop
19 DQ11	49 V _{TT}	79 /S2, NC*	109 DQ57	139 V _{SS}	169 CKE1	199 V _{SS}	229 V _{SS}	A10/AP	Combination input: Addr10/Auto-precharge
20 V _{SS}	50 CKE0	80 V _{SS}	110 V _{SS}	140 DQ20	170 V _{DD}	200 DQ36	230 DM7	V _{SS}	Ground
21 DQ16	51 V _{DD}	81 DQ32	111 /DQS7	141 DQ21	171 A15	201 DQ37	231 NC	V _{DD}	Power
22 DQ17	52 BA2	82 DQ33	112 DQS7	142 V _{SS}	172 A14	202 V _{SS}	232 V _{SS}	V _{DDSPD}	SPD EEPROM Power
23 V _{SS}	53 NC	83 V _{SS}	113 V _{SS}	143 DM2	173 V _{DD}	203 DM4	233 DQ62	V _{REFDQ}	Reference Voltage for DQ's
24 /DQS2	54 V _{DD}	84 /DQS4	114 DQ58	144 NC	174 A12/ /BC	204 NC	234 DQ63	V _{REFCA}	Reference Voltage for CA
25 DQS2	55 A11	85 DQS4	115 DQ59	145 V _{SS}	175 A9	205 V _{SS}	235 V _{SS}	V _{TT}	Termination Voltage
26 V _{SS}	56 A7	86 V _{SS}	116 V _{SS}	146 DQ22	176 V _{DD}	206 DQ38	236 V _{DDSPD}	NC	No Connection
27 DQ18	57 V _{DD}	87 DQ34	117 SA0	147 DQ23	177 A8	207 DQ39	237 SA1		
28 DQ19	58 A5	88 DQ35	118 SCL	148 V _{SS}	178 A6	208 V _{SS}	238 SDA		
29 V _{SS}	59 A4	89 V _{SS}	119 SA2	149 DQ28	179 V _{DD}	209 DQ44	239 V _{SS}		
30 DQ24	60 V _{DD}	90 DQ40	120 V _{TT}	150 DQ29	180 A3	210 DQ45	240 V _{TT}		

* Not used

DTM64384A

8GB - 240-Pin 2Rx8 Unbuffered Non-ECC DDR3 DIMM

Front view

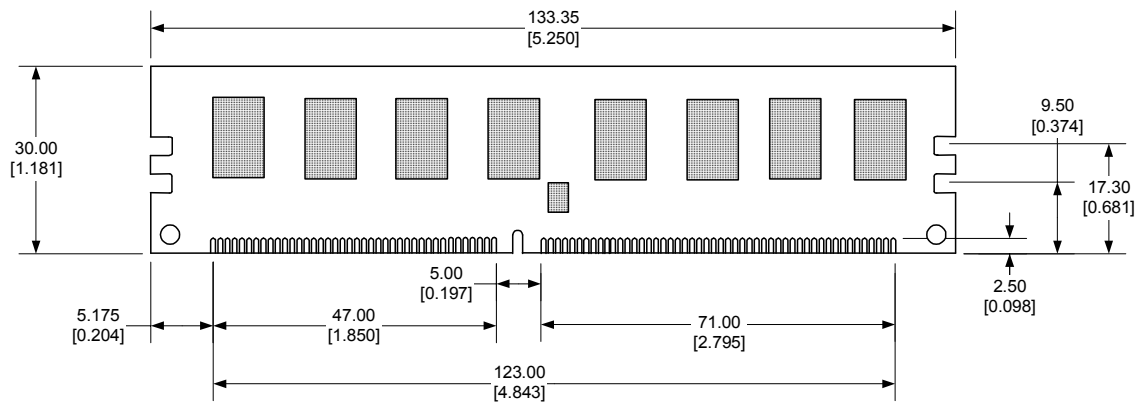

Back view

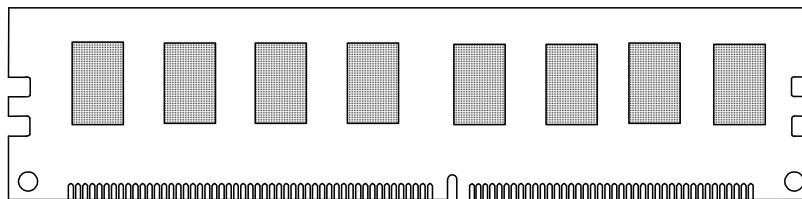

Side view

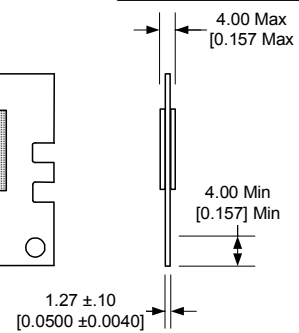

Notes

Tolerances on all dimensions except where otherwise indicated are ± 0.13 (.005).

All dimensions are expressed: millimeters [inches]

DTM64384A

8GB - 240-Pin 2Rx8 Unbuffered Non-ECC DDR3 DIMM

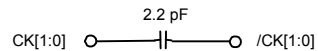
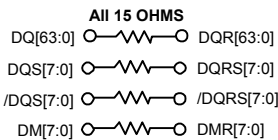
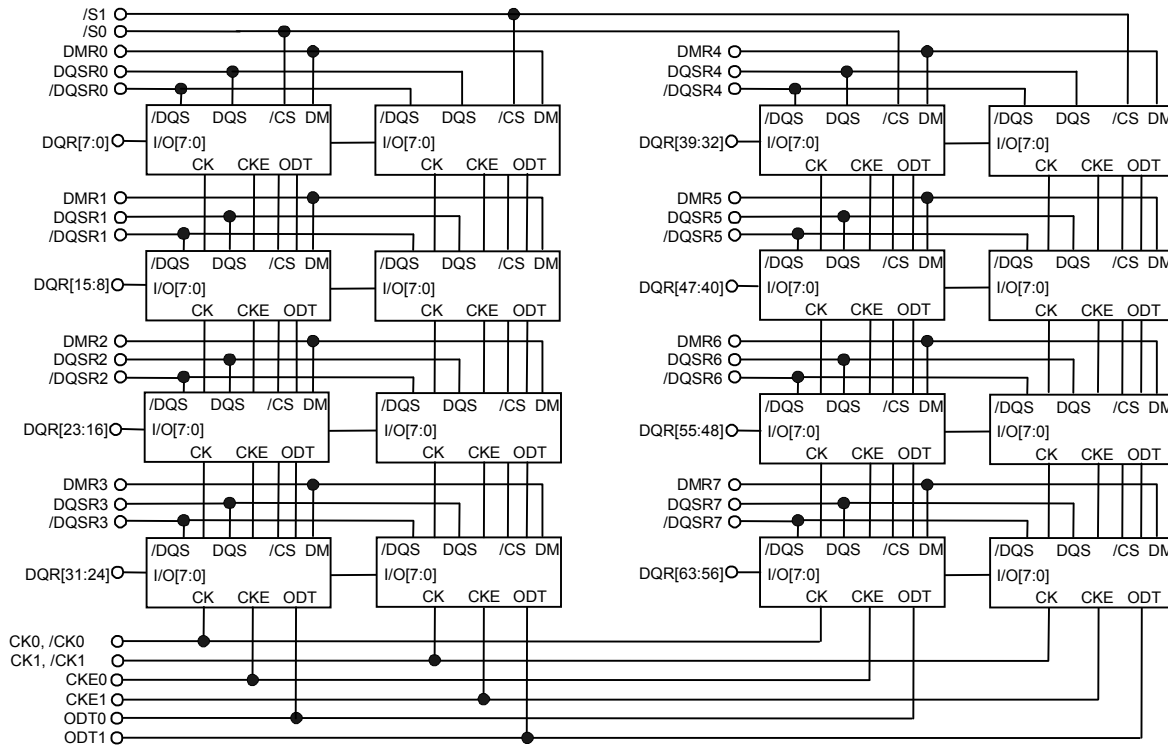

GLOBAL SDRAM CONNECTS

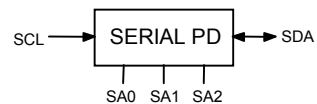
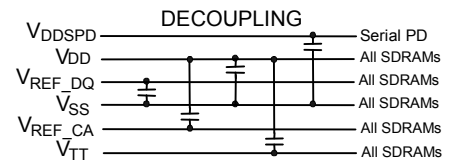
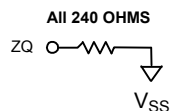
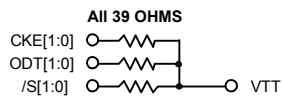
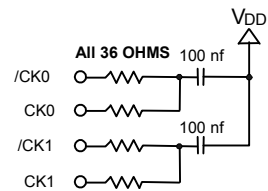
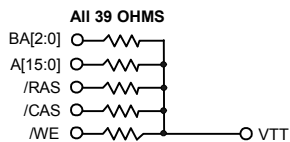



DTM64384A

8GB - 240-Pin 2Rx8 Unbuffered Non-ECC DDR3 DIMM

Absolute Maximum Ratings

(Note: Operation at or above Absolute Maximum Ratings can adversely affect module reliability.)

PARAMETER	Symbol	Minimum	Maximum	Unit
Temperature, non-Operating	$T_{STORAGE}$	-55	100	C
Ambient Temperature, Operating	T_A	0	70	C
DRAM Case Temperature, Operating	T_{CASE}	0	95	C
Voltage on V_{DD} relative to V_{SS}	V_{DD}	-0.4	1.975	V
Voltage on Any Pin relative to V_{SS}	V_{IN}, V_{OUT}	-0.4	1.975	V

Notes:

DRAM Operating Case Temperature above 85C requires 2X refresh.

Recommended DC Operating Conditions ($T_A = 0$ to 70 C, Voltage referenced to $V_{SS} = 0$ V)

PARAMETER	Symbol	Minimum	Typical	Maximum	Unit	Note
Power Supply Voltage	V_{DD}	1.425	1.5	1.575	V	
I/O Reference Voltage	V_{REFDQ}	0.49 V_{DD}	0.50 V_{DD}	0.51 V_{DD}	V	1
I/O Reference Voltage	V_{REFCA}	0.49 V_{DD}	0.50 V_{DD}	0.51 V_{DD}	V	1

Notes:

The value of V_{REF} is expected to equal one-half V_{DD} and to track variations in the V_{DD} DC level. Peak-to-peak noise on V_{REF} may not exceed $\pm 1\%$ of its DC value. For Reference $V_{DD}/2 \pm 15$ mV.

DC Input Logic Levels, Single-Ended ($T_A = 0$ to 70 C, Voltage referenced to $V_{SS} = 0$ V)

PARAMETER	Symbol	Minimum	Maximum	Unit
Logical High (Logic 1)	$V_{IH(DC)}$	$V_{REF} + 0.1$	V_{DD}	V
Logical Low (Logic 0)	$V_{IL(DC)}$	V_{SS}	$V_{REF} - 0.1$	V

AC Input Logic Levels, Single-Ended ($T_A = 0$ to 70 C, Voltage referenced to $V_{SS} = 0$ V)

PARAMETER	Symbol	Minimum	Maximum	Unit
Logical High (Logic 1)	$V_{IH(AC)}$	$V_{REF} + 0.175$	-	V
Logical Low (Logic 0)	$V_{IL(AC)}$	-	$V_{REF} - 0.175$	V

Differential Input Logic Levels ($T_A = 0$ to 70 C, Voltage referenced to $V_{SS} = 0$ V)

PARAMETER	Symbol	Minimum	Maximum	Unit
Differential Input Logic High	$V_{IH,DIFF}$	+0.200	DC: V_{DD} AC: $V_{DD}+0.4$	V
Differential Input Logic Low	$V_{IL,DIFF}$	DC: V_{SS} AC: $V_{SS}-0.4$	-0.200	V
Differential Input Cross Point Voltage relative to $V_{DD}/2$	V_{IX}	- 0.150	+ 0.150	V

Capacitance ($T_A = 25$ C, $f = 100$ MHz)

PARAMETER	Pin	Symbol	Minimum	Maximum	Unit
Input Capacitance, Clock	CK0, /CK0, CK1, /CK1	C_{CK}	8.6	13.4	pF
Input Capacitance, Address	BA[2:0], A[15:0], /RAS, /CAS, /WE	C_i	12	20.8	pF
Input Capacitance Control	/S[1:0], CKE[1:0], ODT[1:0]	C_i	6	10.4	pF
Input/Output Capacitance	DQ[63:0], DQS[7:0], /DQS[7:0], DM[7:0]	C_{DIO}	3	5	pF

DC Characteristics ($T_A = 0$ to 70 C, Voltage referenced to $V_{SS} = 0$ V)

PARAMETER	Symbol	Minimum	Maximum	Unit	Note
Input Leakage Current (Any input 0 V < V_{IN} < V_{DD})	I_{IL}	-16	+32	μ A	1,2
Output Leakage Current (0 V < V_{OUT} < V_{DDQ})	I_{OL}	-10	+10	μ A	2,3

Notes:

- 1) All other pins not under test = 0 V
- 2) Values are shown per pin
- 3) DQ, DQS, DQS and ODT are disabled

I_{DD} Specifications and Conditions (T_A = 0 to 70 C, Voltage referenced to V_{SS} = 0 V)

PARAMETER	Symbol	Test Condition	Max Value	Unit
Operating One Bank Active-Precharge Current	I _{DD0} *	Operating current : One bank ACTIVATE-to-PRECHARGE	480	mA
Operating One Bank Active-Read-Precharge Current	I _{DD1} *	Operating current : One bank ACTIVATE-to-READ-to-PRECHARGE	560	mA
Precharge Power-Down Current	I _{DD2P} **	Precharge power down current: Fast exit	240	mA
Precharge Quiet Standby Current	I _{DD2Q} **	Precharge quiet standby current	320	mA
Precharge Standby Current	I _{DD2N} **	Precharge standby current	320	mA
Active Power-Down Current	I _{DD3P} **	Active power-down current	320	mA
Active Standby Current	I _{DD3N} **	Active standby current	400	mA
Operating Burst Write Current	I _{DD4W} *	Burst write operating current	880	mA
Operating Burst Read Current	I _{DD4R} *	Burst read operating current	840	mA
Burst Refresh Current	I _{DD5} **	Refresh current	1320	mA
Self Refresh Current	I _{DD6} **	Self-refresh temperature current: MAX T _c = 85°C	240	mA
Operating Bank Interleave Read Current	I _{DD7} **	All bank interleaved read current	1520	mA

* One module rank in this operation, the other in IDD2P.

** All module ranks in this operation.

AC Operating Conditions

PARAMETER	Symbol	Min	Max	Unit
Internal read command to first data	t_{AA}	13.125	20	ns
CAS-to-CAS Command Delay	t_{CCD}	4	-	t_{CK}
Clock High Level Width	$t_{CH(avg)}$	0.47	0.53	t_{CK}
Clock Cycle Time	t_{CK}	1.5	3.3	ns
Clock Low Level Width	$t_{CL(avg)}$	0.47	0.53	t_{CK}
Data Input Hold Time after DQS Strobe	t_{DH}	65	-	ps
DQ Input Pulse Width	t_{DIPW}	400	-	ps
DQS Output Access Time from Clock	t_{DQSCK}	-255	+255	ps
Write DQS High Level Width	t_{DQSH}	0.45	0.55	$t_{CK(avg)}$
Write DQS Low Level Width	t_{DQSL}	0.45	0.55	$t_{CK(avg)}$
DQS-Out Edge to Data-Out Edge Skew	t_{DQSQ}	-	125	ps
Data Input Setup Time Before DQS Strobe	t_{DS}	30	-	ps
DQS Falling Edge from Clock, Hold Time	t_{DSH}	0.2	-	$t_{CK(avg)}$
DQS Falling Edge to Clock, Setup Time	t_{DSS}	0.2	-	$t_{CK(avg)}$
Clock Half Period	t_{HP}	minimum of t_{CH} or t_{CL}	-	ns
Address and Command Hold Time after Clock	t_{IH}	140	-	ps
Address and Command Setup Time before Clock	t_{IS}	190	-	ps
Load Mode Command Cycle Time	t_{MRD}	4	-	t_{CK}
DQ-to-DQS Hold	t_{QH}	0.38	-	$t_{CK(avg)}$
Active-to-Precharge Time	t_{RAS}	36	$9 \cdot t_{REFI}$	ns
Active-to-Active / Auto Refresh Time	t_{RC}	49.125	-	ns
RAS-to-CAS Delay	t_{RCD}	13.125	-	ns
Average Periodic Refresh Interval	t_{REFI}	-	7.8	μ s
Auto Refresh Row Cycle Time	t_{RFC}	260	-	ns
Row Precharge Time	t_{RP}	13.125	-	ns
Read DQS Preamble Time	t_{RPRE}	0.9	Note-1	$t_{CK(avg)}$
Read DQS Postamble Time	t_{RPST}	0.3	Note-2	$t_{CK(avg)}$
Row Active to Row Active Delay	t_{RRD}	Max(4nCK, 6ns)	-	ns
Internal Read to Precharge Command Delay	t_{RTP}	Max(4nCK, 7.5ns)	-	ns
Write DQS Preamble Setup Time	t_{WPRE}	0.9	-	$t_{CK(avg)}$
Write DQS Postamble Time	t_{WPST}	0.4	-	$t_{CK(avg)}$
Write Recovery Time	t_{WR}	15	-	ns
Internal Write to Read Command Delay	t_{WTR}	Max(4nCK, 7.5ns)	-	ns

Notes:

1. The maximum preamble is bound by $t_{LZDQS}(\min)$
2. The maximum postamble is bound by $t_{HZDQS}(\max)$

SERIAL PRESENCE DETECT MATRIX

Byte#	Function.	Value	Hex
0	Number of Bytes Used / Number of Bytes in SPD Device / CRC Coverage.		0x92
	Bit 3 ~ Bit 0. SPD Bytes Used -	176	
	Bit 6 ~ Bit 4. SPD Bytes Total -	256	
	Bit 7. CRC Coverage -	Bytes 0-116	
1	SPD Revision.	Rev. 1.1	0x11
2	Key Byte / DRAM Device Type.	DDR3 SDRAM	0x0B
3	Key Byte / Module Type.		0x02
	Bit 3 ~ Bit 0. Module Type -	UDIMM	
	Bit 7 ~ Bit 4. Reserved -	0	
4	SDRAM Density and Banks.		0x04
	Bit 3 ~ Bit 0. Total SDRAM capacity, in megabits -	4Gb	
	Bit 6 ~ Bit 4. Bank Address Bits -	8 banks	
	Bit 7. Reserved -	0	
5	SDRAM Addressing.		0x21
	Bit 2 ~ Bit 0. Column Address Bits -	10	
	Bit 5 ~ Bit 3. Row Address Bits -	16	
	Bit 7, 6. Reserved	0	
6	Module Nominal Voltage, VDD.		0x00
	Bit 0. NOT 1.5 V operable -		
	Bit 1. 1.35 V operable -		
	Bit 2. 1.2X V operable -		
	Bit 3. Reserved -		
	Bit 4. Reserved -		
	Bit 5. Reserved -		
	Bit 6. Reserved -		
7	Module Organization.		0x09
	Bit 2 ~ Bit 0. SDRAM Device Width -	8-Bits	
	Bit 5 ~ Bit 3. Number of Ranks -	2-Rank	
	Bit 7, 6. Reserved	0	
8	Module Memory Bus Width.		0x03
	Bit 2 ~ Bit 0. Primary bus width, in bits -	64-Bits	
	Bit 4, Bit 3. Bus width extension, in bits -	0-Bits	
	Bit 7 ~ Bit 5. Reserved -	0	
9	Fine Timebase (FTB) Dividend / Divisor.		0x11
	Bit 3 ~ Bit 0. Fine Timebase (FTB) Divisor	1	
	Bit 7 ~ Bit 4. Fine Timebase (FTB) Dividend	1	
10	Medium Timebase (MTB) Dividend.	1 (MTB = 0.125ns)	0x01

DTM64384A

8GB - 240-Pin 2Rx8 Unbuffered Non-ECC DDR3 DIMM

11	Medium Timebase (MTB) Divisor.	8 (MTB = 0.125ns)	0x08	
12	SDRAM Minimum Cycle Time (tCKmin).	1.5ns	0x0C	
13	Reserved.	UNUSED	0x00	
14	CAS Latencies Supported, Least Significant Byte.		0x3C	
	Bit 0. CL = 4 -			
	Bit 1. CL = 5 -			
	Bit 2. CL = 6 - X			
	Bit 3. CL = 7 - X			
	Bit 4. CL = 8 - X			
	Bit 5. CL = 9 - X			
	Bit 6. CL = 10 -			
Bit 7. CL = 11 -				
15	CAS Latencies Supported, Most Significant Byte.		0x00	
	Bit 0. CL = 12 -			
	Bit 1. CL = 13 -			
	Bit 2. CL = 14 -			
	Bit 3. CL = 15 -			
	Bit 4. CL = 16 -			
	Bit 5. CL = 17 -			
	Bit 6. CL = 18 -			
Bit 7. Reserved.				
16	Minimum CAS Latency Time (tAmin).	13.125ns	0x69	
17	Minimum Write Recovery Time (tWRmin).	15.0ns	0x78	
18	Minimum RAS# to CAS# Delay Time (tRCDmin).	13.125ns	0x69	
19	Minimum Row Active to Row Active Delay Time (tRRDmin).	6.0ns	0x30	
20		Minimum Row Precharge Delay Time (tRPmin).	13.125ns	0x69
21	Upper Nibbles for tRAS and tRC.		0x11	
	Bit 3 ~ Bit 0. tRAS Most Significant Nibble -			1
	Bit 7 ~ Bit 4. tRC Most Significant Nibble -			1
22	Minimum Active to Precharge Delay Time (tRASmin), Least Significant Byte.	36.0ns	0x20	
23	Minimum Active to Active/Refresh Delay Time (tRCmin), Least Significant Byte.	49.125ns	0x89	
24	Minimum Refresh Recovery Delay Time (tRFCmin), Least Significant Byte.	260.0ns	0x20	
25	Minimum Refresh Recovery Delay Time (tRFCmin), Most Significant Byte.	260.0ns	0x08	
26	Minimum Internal Write to Read Command Delay Time (tWTRmin).	7.5ns	0x3C	
27	Minimum Internal Read to Precharge Command Delay Time (tRTPmin).	7.5ns	0x3C	
28	Upper Nibble for tFAW.		0x00	
	Bit 3 ~ Bit 0. tFAW Most Significant Nibble -			0
	Bit 7 ~ Bit 4. Reserved -			0

29	Minimum Four Activate Window Delay Time (tFAWmin), Least Significant Byte.	30.0ns	0xF0
30	SDRAM Optional Features.		0x83
	Bit 0. RZQ / 6 -	X	
	Bit 1. RZQ / 7 -	X	
	Bit 6 ~ Bit 2. Reserved - Bit 7. DLL-Off Mode Support		
31	SDRAM Drivers Supported.		0x01
	Extended Temperature Range -	X	
	Extended Temperature Refresh Rate -		
	Auto Self Refresh (ASR) -		
	On-die Thermal Sensor (ODTS) Readout -		
	Reserved -		
	Reserved -		
	Reserved -		
32	Module Thermal Sensor.		0x00
	Bit 6 ~ Bit 0. Thermal Sensor Accuracy -	0	
	Bit 7. Thermal Sensor -	No TS	
33	SDRAM Device Type.		0x00
	Bit 6 ~ Bit 0. Non-Standard Device Description - Bit 7. SDRAM Device Type -	0 Std Mono	
34-59	Reserved	UNUSED	0x00
60	Module Nominal Height.		0x0F
	Bit 4 ~ Bit 0. Module Nominal Height max, in mm -	29<h<=30	
	Bit 7 ~ Bit5. Reserved -	0	
61	Module Maximum Thickness.		0x11
	Bit 3 ~ Bit 0. Front, in mm (baseline thickness = 1 mm) -	1<th<=2	
	Bit 7 ~ Bit 4. Back, in mm (baseline thickness = 1 mm) -	1<th<=2	
62	Reference Raw Card Used.		0x21
	Bit 4 ~ Bit 0. Reference Raw Card -	R/C B	
	Bit 6, Bit 5. Reference Raw Card Revision -	Rev.1	
	Bit 7. Reserved -	0	
63	Address Mapping from Edge Connector to DRAM.		0x01
	Bit 0. Rank 1 Mapping (Registered DIMM - Reserved) -	Mirrored	
	Bit 7 ~ Bit 1. Reserved -	0	
64-116	Module-Specific Section	UNUSED	0x00
117	Module Manufacturer ID Code, Least Significant Byte		0x80
118	Module Manufacturer ID Code, Most Significant Byte		0xCE
119	Module Manufacturing Location		0x01
120	Module Manufacturing Date		0x11



DTM64384A

8GB - 240-Pin 2Rx8 Unbuffered Non-ECC DDR3 DIMM

121	Module Manufacturing Date		0x34
122	Module Serial Number		0x42
123	Module Serial Number		0x2F
124	Module Serial Number		0x97
125	Module Serial Number		0x0C
126	Cyclical Redundancy Code (CRC).	CRC	0x11
127	Cyclical Redundancy Code (CRC).	CRC	0xA2
128	Module Part Number	M	0x4D
129	Module Part Number	3	0x33
130	Module Part Number	7	0x37
131	Module Part Number	8	0x38
132	Module Part Number	B	0x42
133	Module Part Number	1	0x31
134	Module Part Number	G	0x47
135	Module Part Number	7	0x37
136	Module Part Number	3	0x33
137	Module Part Number	B	0x42
138	Module Part Number	H	0x48
139	Module Part Number	0	0x30
140	Module Part Number	-	0x2D
141	Module Part Number	C	0x43
142	Module Part Number	H	0x48
143	Module Part Number	9	0x39
144, 145	Module Part Number		0x20
146, 147	Module Revision Code	UNUSED	0x00
148	DRAM Manufacturer ID Code, Least Significant Byte		0x80
149	DRAM Manufacturer ID Code, Most Significant Byte		0xCE
150- 175	Manufacturer's Specific Data	UNUSED	0x00
176- 255	Open for customer use	UNUSED	0x00

Note: Bytes 119 – 125 and 150 - 255 may be different than shown.



DTM64384A

8GB - 240-Pin 2Rx8 Unbuffered Non-ECC DDR3 DIMM



DATARAM CORPORATION, USA Corporate Headquarters, P.O.Box 7528, Princeton, NJ 08543-7528;
Voice: 609-799-0071, Fax: 609-799-6734; www.dataram.com

All rights reserved.

The information contained in this document has been carefully checked and is believed to be reliable. However, Dataram assumes no responsibility for inaccuracies.

The information contained in this document does not convey any license under the copyrights, patent rights or trademarks claimed and owned by Dataram.

No part of this publication may be copied or reproduced in any form or by any means, or transferred to any third party without prior written consent of Dataram.