

DTM64422A

8GB - 240-Pin 2Rx8 Registered ECC LV DDR3 DIMM



Identification

DTM64422A 1Gx72
8GB 2Rx8 PC3L-12800R-11-11-B1

Performance range

Clock / Module Speed / CL-t_{RCD} -t_{RP}

800 MHz / PC3-12800 / 11-11-11
667 MHz / PC3-10600 / 10-10-10
667 MHz / PC3-10600 / 9-9-9
533 MHz / PC3-8500 / 8-8-8
533 MHz / PC3-8500 / 7-7-7
400 MHz / PC3-6400 / 6-6-6

Features

240-pin JEDEC-compliant DIMM, 133.35 mm wide by 30 mm high

Operating Voltage: VDD = VDDQ = +1.35V (1.283V to 1.45V)

Backward-compatible to VDD = VDDQ = +1.5V ±0.075V

On-board I2C temperature sensor with integrated serial presence-detect (SPD) EEPROM

Data Transfer Rate: 12.8 Gigabytes/sec

Data Bursts: 8 and burst chop 4 mode

ZQ Calibration for Output Driver and On-Die Termination (ODT)

Programmable ODT / Dynamic ODT during Writes

Programmable CAS Latency: 6, 7, 8, 9, 10 and 11

Bi-Directional Differential Data Strobe signals

SDRAM Addressing (Row/Col/Bank): 16/10/3

Fully RoHS Compliant

Description

DTM64422A is a registered 1Gx72 memory module, which conforms to JEDEC's DDR3, PC3L-10600 standard. The assembly is Dual-Rank. Each Rank is comprised of nine 512Mx8 DDR3 Hynix SDRAMs. One 2K-bit EEPROM is used for Serial Presence Detect and a combination register/PLL, with Address and Command Parity, is also used.

Both output driver strength and input termination impedance are programmable to maintain signal integrity on the I/O signals in a Fly-by topology.

A thermal sensor accurately monitors the DIMM module and can prevent exceeding the maximum operating temperature of 95C.

Pin Configuration

Pin Description

Front Side			Back Side				Name	Function	
1 V _{REFDQ}	31 DQ25	61 A2	91 DQ41	121 V _{SS}	151 V _{SS}	181 A1	211 V _{SS}	CB[7:0]	Data Check Bits
2 V _{SS}	32 V _{SS}	62 V _{DD}	92 V _{SS}	122 DQ4	152 DM3	182 V _{DD}	212 DM5	DQ[63:0]	Data Bits
3 DQ0	33 /DQS3	63 CK1*	93 /DQS5	123 DQ5	153 /TDQS12	183 V _{DD}	213 /TDQS14	DQS[8:0], /DQS[8:0]	Differential Data Strobes
4 DQ1	34 DQS3	64 /CK1*	94 DQS5	124 V _{SS}	154 V _{SS}	184 CK0	214 V _{SS}	DM[8:0]	Data Mask
5 V _{SS}	35 V _{SS}	65 V _{DD}	95 V _{SS}	125 DM0	155 DQ30	185 /CK0	215 DQ46	/TDQS[17:9]	Termination Data Strobe
6 /DQS0	36 DQ26	66 V _{DD}	96 DQ42	126 /TDQS9	156 DQ31	186 V _{DD}	216 DQ47	CK[1:0], /CK[1:0]	Differential Clock Inputs
7 DQS0	37 DQ27	67 V _{REFCA}	97 DQ43	127 V _{SS}	157 V _{SS}	187 /Event	217 V _{SS}	CKE[1:0]	Clock Enables
8 V _{SS}	38 V _{SS}	68 P _{AR_IN}	98 V _{SS}	128 DQ6	158 CB4	188 A0	218 DQ52	/CAS	Column Address Strobe
9 DQ2	39 CB0	69 VDD	99 DQ48	129 DQ7	159 CB5	189 V _{DD}	219 DQ53	/RAS	Row Address Strobe
10 DQ3	40 CB1	70 A10/AP	100 DQ49	130 V _{SS}	160 V _{SS}	190 BA1	220 V _{SS}	/S[3:0]	Chip Selects
11 V _{SS}	41 V _{SS}	71 BA0	101 V _{SS}	131 DQ12	161 DM8	191 V _{DD}	221 DM6	/WE	Write Enable
12 DQ8	42 /DQS8	72 V _{DD}	102 /DQS6	132 DQ13	162 /TDQS17	192 /RAS	222 /TDQS15	A[15:0]	Address Inputs
13 DQ9	43 DQS8	73 /WE	103 DQS6	133 V _{SS}	163 V _{SS}	193 /S0	223 V _{SS}	BA[2:0]	Bank Addresses
14 V _{SS}	44 V _{SS}	74 /CAS	104 V _{SS}	134 DM1	164 CB6	194 V _{DD}	224 DQ54	ODT[1:0]	On Die Termination Inputs
15 /DQS1	45 CB2	75 V _{DD}	105 DQ50	135 /TDQS10	165 CB7	195 ODT0	225 DQ55	SA[2:0]	SPD Address
16 DQS1	46 CB3	76 /S1	106 DQ51	136 V _{SS}	166 V _{SS}	196 A13	226 V _{SS}	SCL	SPD Clock Input
17 V _{SS}	47 V _{SS}	77 ODT1	107 V _{SS}	137 DQ14	167 NC (TEST)	197 V _{DD}	227 DQ60	SDA	SPD Data Input/Output
18 DQ10	48 V _{TT}	78 V _{DD}	108 DQ56	138 DQ15	168 /RESET	198 /S3, NC	228 DQ61	/EVENT	Temperature Sensing
19 DQ11	49 V _{TT}	79 /S2, NC	109 DQ57	139 V _{SS}	169 CKE1	199 V _{SS}	229 V _{SS}	/RESET	Reset for register and DRAMs
20 V _{SS}	50 CKE0	80 V _{SS}	110 V _{SS}	140 DQ20	170 V _{DD}	200 DQ36	230 DM7	PAR_IN	Parity bit for Addr/Ctrl
21 DQ16	51 V _{DD}	81 DQ32	111 /DQS7	141 DQ21	171 A15	201 DQ37	231 /TDQS16	/ERR_OUT	Error bit for Parity Error
22 DQ17	52 BA2	82 DQ33	112 DQS7	142 V _{SS}	172 A14	202 V _{SS}	232 V _{SS}	A12/BC	Combination input: Addr12/Burst Chop
23 V _{SS}	53 /ERR_OUT	83 V _{SS}	113 V _{SS}	143 DM2	173 V _{DD}	203 DM4	233 DQ62	A10/AP	Combination input: Addr10/Auto-precharge
24 /DQS2	54 V _{DD}	84 /DQS4	114 DQ58	144 /TDQS11	174 A12/BC	204 /TDQS13	234 DQ63	V _{SS}	Ground
25 DQS2	55 A11	85 DQS4	115 DQ59	145 V _{SS}	175 A9	205 V _{SS}	235 V _{SS}	V _{DD}	Power
26 V _{SS}	56 A7	86 V _{SS}	116 V _{SS}	146 DQ22	176 V _{DD}	206 DQ38	236 V _{DDSPD}	V _{DDSPD}	SPD EEPROM Power
27 DQ18	57 V _{DD}	87 DQ34	117 SA0	147 DQ23	177 A8	207 DQ39	237 SA1	V _{REFDQ}	Reference Voltage for DQ's
28 DQ19	58 A5	88 DQ35	118 SCL	148 V _{SS}	178 A6	208 V _{SS}	238 SDA	V _{REFCA}	Reference Voltage for CA
29 V _{SS}	59 A4	89 V _{SS}	119 SA2	149 DQ28	179 V _{DD}	209 DQ44	239 V _{SS}	V _{TT}	Termination Voltage
30 DQ24	60 V _{DD}	90 DQ40	120 V _T	150 DQ29	180 A3	210 DQ45	240 V _{TT}	NC	No Connection

* = Not used

Front view

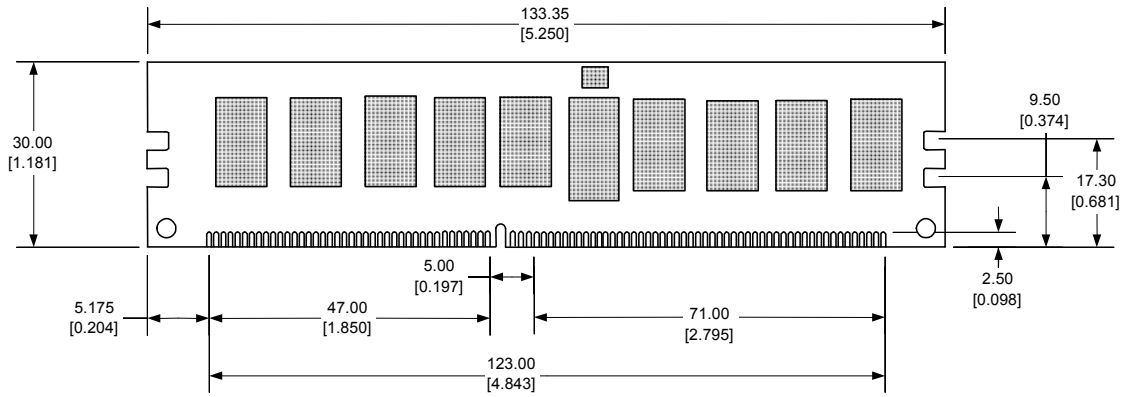

Back view

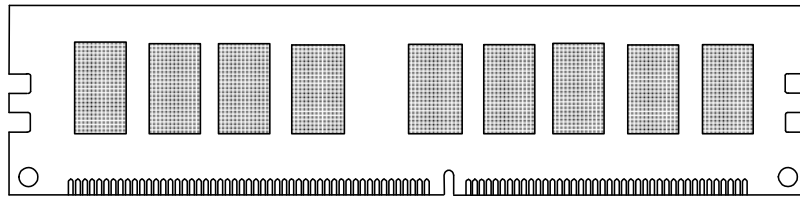

Side view

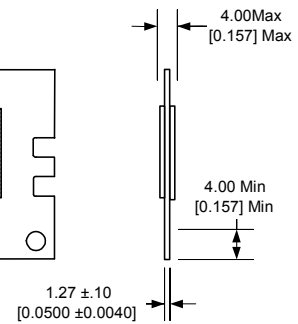

Notes

Tolerances on all dimensions except where otherwise indicated are $\pm .13$ (.005).

All dimensions are expressed: millimeters [inches]

DTM64422A

8GB - 240-Pin 2Rx8 Registered ECC LV DDR3 DIMM

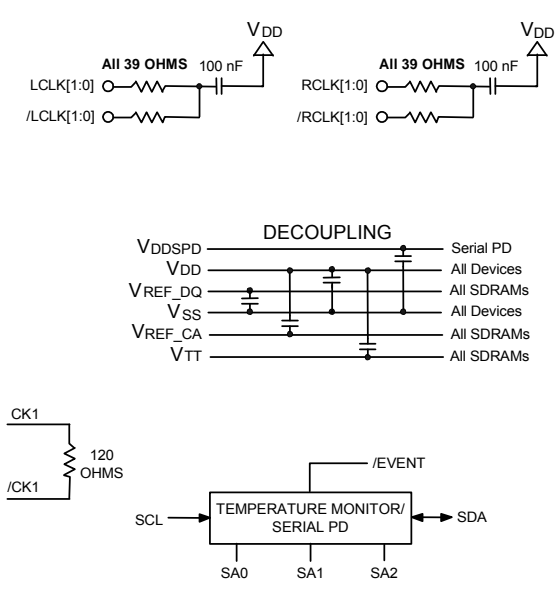
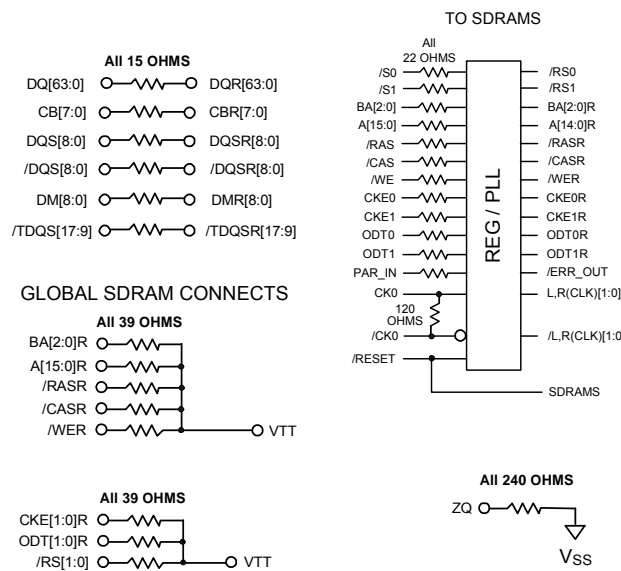
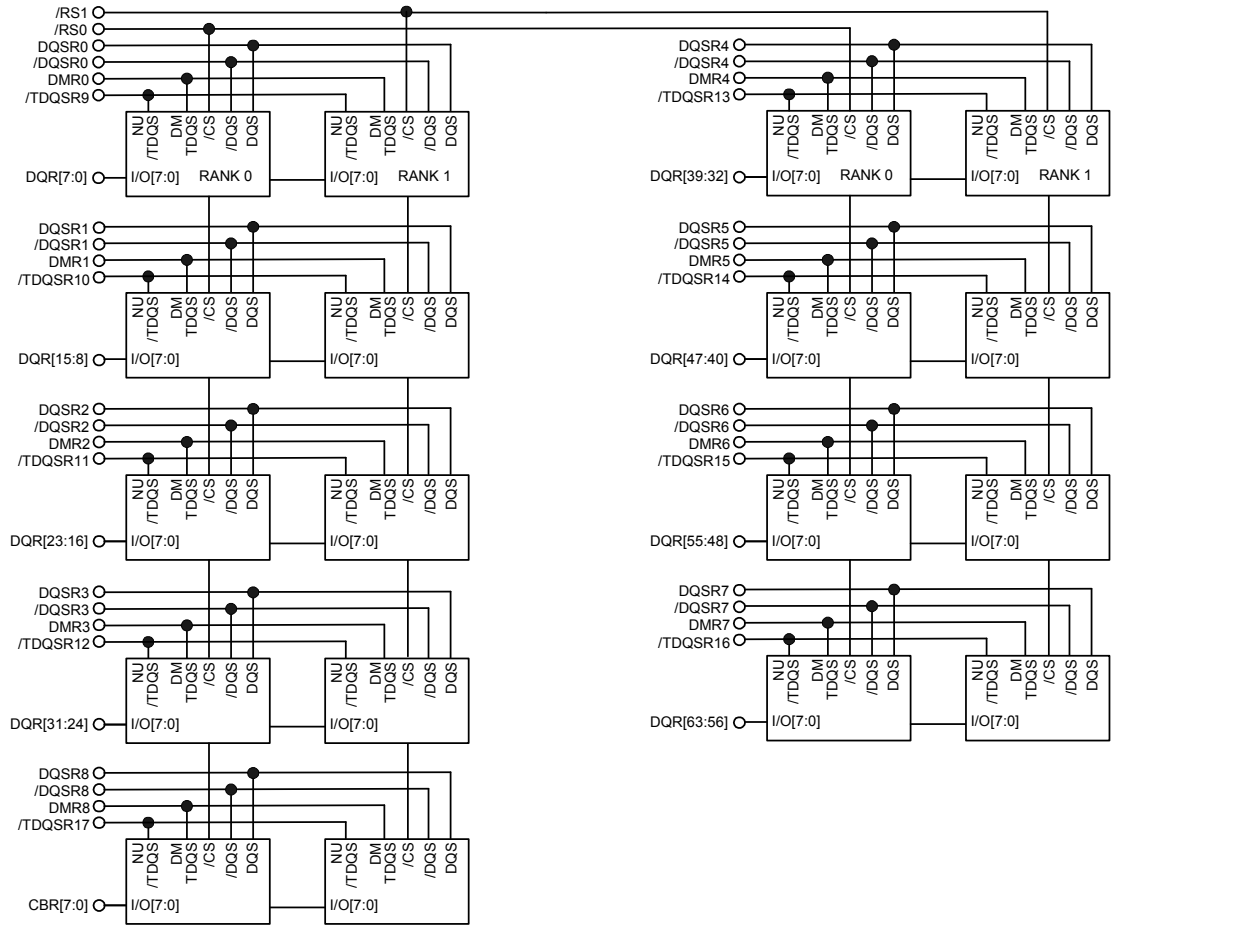

Absolute Maximum Ratings

(Note: Operation at or above Absolute Maximum Ratings can adversely affect module reliability.)

PARAMETER	Symbol	Minimum	Maximum	Unit
Temperature, non-Operating	$T_{STORAGE}$	-55	100	C
Ambient Temperature, Operating	T_A	0	70	C
DRAM Case Temperature, Operating	T_{CASE}	0	95	C
Voltage on V_{DD} relative to V_{SS}	V_{DD}	-0.4	1.975	V
Voltage on Any Pin relative to V_{SS}	V_{IN}, V_{OUT}	-0.4	1.975	V

Notes:

DRAM Operating Case Temperature above 85C requires 2X refresh.

Recommended DC Operating Conditions ($T_A = 0$ to 70 C, Voltage referenced to $V_{SS} = 0$ V)

PARAMETER	Symbol	Operation Voltage	Minimum	Typical	Maximum	Unit	Note
Power Supply Voltage	V_{DD}	1.35V	1.283	1.35	1.4500	V	
		1.5V	1.425	1.5	1.575		
I/O Reference Voltage	V_{REFDQ}	1.35V	0.49 V_{DD}	0.50 V_{DD}	0.51 V_{DD}	V	1
		1.5V					
I/O Reference Voltage	V_{REFCA}	1.35V	0.49 V_{DD}	0.50 V_{DD}	0.51 V_{DD}	V	1
		1.5V					

Notes:

1) The value of V_{REF} is expected to equal one-half V_{DD} and to track variations in the V_{DD} DC level. Peak-to-peak noise on V_{REF} may not exceed $\pm 1\%$ of its DC value.

DC Input Logic Levels, Single-Ended ($T_A = 0$ to 70 C, Voltage referenced to $V_{SS} = 0$ V)

PARAMETER	Symbol	Operation Voltage	Minimum	Maximum	Unit
Logical High (Logic 1)	$V_{IH(DC)}$	1.35V	$V_{REF} + 0.09$	V_{DD}	V
		1.5V	$V_{REF} + 0.1$	V_{DD}	
Logical Low (Logic 0)	$V_{IL(DC)}$	1.35V	V_{SS}	$V_{REF} - 0.09$	V
		1.5V	V_{SS}	$V_{REF} - 0.1$	

AC Input Logic Levels, Single-Ended ($T_A = 0$ to 70 C, Voltage referenced to $V_{SS} = 0$ V)

PARAMETER	Symbol	Operation Voltage	Minimum	Maximum	Unit
Logical High (Logic 1)	$V_{IH(AC)}$	1.35V	$V_{REF} + 0.160$	-	V
		1.5V	$V_{REF} + 0.175$	-	
Logical Low (Logic 0)	$V_{IL(AC)}$	1.35V	-	$V_{REF} - 0.160$	V
		1.5V	-	$V_{REF} - 0.175$	

Differential Input Logic Levels ($T_A = 0$ to 70 C, Voltage referenced to $V_{SS} = 0$ V)

PARAMETER	Symbol	Minimum	Maximum	Unit
Differential Input Logic High	$V_{IH,DIFF}$	+0.200	DC: V_{DD} AC: $V_{DD}+0.4$	V
Differential Input Logic Low	$V_{IL,DIFF}$	DC: V_{SS} AC: $V_{SS}-0.4$	-0.200	V
Differential Input Cross Point Voltage relative to $V_{DD}/2$	V_{IX}	- 0.150	+ 0.150	V

Capacitance ($T_A = 25$ C, $f = 100$ MHz)

PARAMETER	Pin	Symbol	Minimum	Maximum	Unit
Input Capacitance, Clock	CK0, /CK0	C_{CK}	1.5	2.5	pF
Input Capacitance, Address	BA[2:0], A[15:0], /RAS, /CAS, /WE	C_I	1.5	2.5	pF
Input Capacitance Control	/S[1:0], CKE[1:0], ODT[1:0]	C_I	1.5	2.5	pF
Input/Output Capacitance	DQ[63:0], CB[7:0] DQS[8:0], /DQS[8:0], DM[8:0], /TDQS[17:9]	C_{IO}	2.8	5	pF

DC Characteristics ($T_A = 0$ to 70 C, Voltage referenced to $V_{SS} = 0$ V)

PARAMETER	Symbol	Minimum	Maximum	Unit	Note
Input Leakage Current (Any input 0 V < V_{IN} < V_{DD})	I_{IL}	-18	+18	μ A	1,2
Output Leakage Current (0 V < V_{OUT} < V_{DDQ})	I_{OL}	-10	+10	μ A	2,3

Notes:

- 1) All other pins not under test = 0 V
- 2) Values are shown per pin
- 3) DQ, DQS, DQS and ODT are disabled

I_{DD} Specifications and Conditions (T_A = 0 to 70 C, Voltage referenced to V_{SS} = 0 V)

PARAMETER	Symbol	Test Condition	Max Value		Unit
			1.35V	1.5V	
Operating One Bank Active-Precharge Current	I _{DD0} *	Operating current : One bank ACTIVATE-to-PRECHARGE	1295	1385	mA
Operating One Bank Active-Read-Precharge Current	I _{DD1} *	Operating current : One bank ACTIVATE-to-READ-to-PRECHARGE	1358	1457	mA
Precharge Power-Down Current	I _{DD2P} **	Precharge power down current: (Slow exit)	372	426	mA
Precharge Power-Down Current	I _{DD2P} **	Precharge power down current: (Fast exit)	408	462	mA
Precharge Quiet Standby Current	I _{DD2Q} **	Precharge quiet standby current	1070	1160	mA
Precharge Standby Current	I _{DD2N} **	Precharge standby current	1088	1142	mA
Active Power-Down Current	I _{DD3P} **	Active power-down current	552	606	mA
Active Standby Current	I _{DD3N} **	Active standby current	1232	1322	mA
Operating Burst Write Current	I _{DD4W} *	Burst write operating current	1808	1943	mA
Operating Burst Read Current	I _{DD4R} *	Burst read operating current	1763	1898	mA
Burst Refresh Current	I _{DD5B} **	Refresh current	2798	2843	mA
Self Refresh Current	I _{DD6} **	Self-refresh temperature current: MAX T _C = 85°C	444	498	mA
Operating Bank Interleave Read Current	I _{DD7} *	All bank interleaved read current	2213	2393	mA

* One module rank in this operation, the rest in IDD2N slow exit.

** All module ranks in this operation.

AC Operating Conditions

PARAMETER	Symbol	Min	Max	Unit
Internal read command to first data	t_{AA}	13.125	20	ns
CAS-to-CAS Command Delay	t_{CCD}	4	-	t_{CK}
Clock High Level Width	$t_{CH(avg)}$	0.47	0.53	t_{CK}
Clock Cycle Time	t_{CK}	1.5	1.875	ns
Clock Low Level Width	$t_{CL(avg)}$	0.47	0.53	t_{CK}
Data Input Hold Time after DQS Strobe	t_{DH}	45	-	ps
DQ Input Pulse Width	t_{DIPW}	360	-	ps
DQS Output Access Time from Clock	t_{DQSCK}	-225	+225	ps
Write DQS High Level Width	t_{DQSH}	0.45	0.55	$t_{CK(avg)}$
Write DQS Low Level Width	t_{DQSL}	0.45	0.55	$t_{CK(avg)}$
DQS-Out Edge to Data-Out Edge Skew	t_{DQSQ}	-	100	ps
Data Input Setup Time Before DQS Strobe	t_{DS}	10	-	ps
DQS Falling Edge from Clock, Hold Time	t_{DSH}	0.18	-	$t_{CK(avg)}$
DQS Falling Edge to Clock, Setup Time	t_{DSS}	0.18	-	$t_{CK(avg)}$
Clock Half Period	t_{HP}	minimum of t_{CH} or t_{CL}	-	ns
Address and Command Hold Time after Clock	t_{IH}	120	-	ps
Address and Command Setup Time before Clock	t_{IS}	45	-	ps
Load Mode Command Cycle Time	t_{MRD}	4	-	t_{CK}
DQ-to-DQS Hold	t_{QH}	0.38	-	$t_{CK(avg)}$
Active-to-Precharge Time	t_{RAS}	35	$9 \cdot t_{REFI}$	ns
Active-to-Active / Auto Refresh Time	t_{RC}	48.125	-	ns
RAS-to-CAS Delay	t_{RCD}	13.125	-	ns
Average Periodic Refresh Interval $0^{\circ}C \leq T_{CASE} < 85^{\circ}C$	t_{REFI}	-	7.8	μs
Average Periodic Refresh Interval $0^{\circ}C \leq T_{CASE} < 95^{\circ}C$	t_{REFI}	-	3.9	μs
Auto Refresh Row Cycle Time	t_{RFC}	260	-	ns
Row Precharge Time	t_{RP}	13.125	-	ns
Read DQS Preamble Time	t_{RPRE}	0.9	Note-1	$t_{CK(avg)}$
Read DQS Postamble Time	t_{RPST}	0.3	Note-2	$t_{CK(avg)}$
Row Active to Row Active Delay	t_{RRD}	Max(4nCK, 6ns)	-	ns
Internal Read to Precharge Command Delay	t_{RTP}	Max(4nCK, 7.5ns)	-	ns
Write DQS Preamble Setup Time	t_{WPRE}	0.9	-	$t_{CK(avg)}$
Write DQS Postamble Time	t_{WPST}	0.3	-	$t_{CK(avg)}$
Write Recovery Time	t_{WR}	15	-	ns
Internal Write to Read Command Delay	t_{WTR}	Max(4nCK, 7.5ns)	-	ns

Notes:

1. The maximum preamble is bound by $t_{LZDQS}(\min)$
2. The maximum postamble is bound by $t_{HZDQS}(\max)$



DTM64422A

8GB - 240-Pin 2Rx8 Registered ECC LV DDR3 DIMM



DATARAM CORPORATION, USA Corporate Headquarters, P.O. Box 7528, Princeton, NJ 08543-7528;
Voice: 609-799-0071, Fax: 609-799-6734; www.dataram.com

All rights reserved.

The information contained in this document has been carefully checked and is believed to be reliable. However, Dataram assumes no responsibility for inaccuracies.

The information contained in this document does not convey any license under the copyrights, patent rights or trademarks claimed and owned by Dataram.

No part of this publication may be copied or reproduced in any form or by any means, or transferred to any third party without prior written consent of Dataram.