

DTM64378C

8GB - 240-Pin 2Rx4 Registered ECC DDR3 DIMM



Identification

DTM64378C 1Gx72
 8GB 2Rx4 PC3-12800R-11-11-E2

Performance range

Clock / Module Speed / CL-t_{RCD}-t_{RP}

800 MHz / PC3-12800 / 11-11-11
 667 MHz / PC3-10600 / 10-10-10
 667 MHz / PC3-10600 / 9-9-9
 533 MHz / PC3-8500 / 8-8-8
 533 MHz / PC3-8500 / 7-7-7
 400 MHz / PC3-6400 / 6-6-6

Features

240-pin JEDEC-compliant DIMM, 133.35 mm wide by 30 mm high

Operating Voltage: 1.5V ±0.075

I/O Type: SSTL_15

On-board I²C temperature sensor with integrated Serial Presence-Detect (SPD) EEPROM

Data Transfer Rate: 12.8 Gigabytes/sec

Data Bursts: 8 and burst chop 4 mode

ZQ Calibration for Output Driver and On-Die Termination (ODT)

Programmable ODT / Dynamic ODT during Writes

Programmable CAS Latency: 6, 7, 8, 9, 10, and 11

Bi-directional Differential Data Strobe signals

SDRAM Addressing (Row/Col/Bank): 15/11/3

Fully RoHS Compliant

Description

DTM64378C is a registered 1Gx72 memory module, which conforms to JEDEC's DDR3, PC3-12800 standard. The assembly is Dual-Rank. Each Rank is comprised of eighteen Hynix 512Mx4 DDR3-1600 SDRAMs. One 2K-bit EEPROM is used for Serial Presence Detect and a combination register/PLL, with Address and Command Parity, is also used.

Both output driver strength and input termination impedance are programmable to maintain signal integrity on the I/O signals in a Fly-by topology. A thermal sensor accurately monitors the DIMM module and can prevent exceeding the maximum operating temperature of 95C.

Pin Configuration

Pin Description

Front Side				Back Side				Name	Function
1 V _{REFDQ}	31 DQ25	61 A2	91 DQ41	121 V _{SS}	151 V _{SS}	181 A1	211 V _{SS}	CB[7:0]	Data Check Bits
2 V _{SS}	32 V _{SS}	62 V _{DD}	92 V _{SS}	122 DQ4	152 DQS12	182 V _{DD}	212 DQS14	DQ[63:0]	Data Bits
3 DQ0	33 /DQS3	63 CK1*	93 /DQS5	123 DQ5	153 /DQS12	183 V _{DD}	213 /DQS14	DQS[17:0], /DQS[17:0]	Differential Data Strobes
4 DQ1	34 DQS3	64 /CK1*	94 DQS5	124 V _{SS}	154 V _{SS}	184 CK0	214 V _{SS}	CK[1:0], /CK[1:0]	Differential Clock Inputs
5 V _{SS}	35 V _{SS}	65 V _{DD}	95 V _{SS}	125 DQS9	155 DQ30	185 /CK0	215 DQ46	CKE[1:0]	Clock Enables
6 /DQS0	36 DQ26	66 V _{DD}	96 DQ42	126 /DQS9	156 DQ31	186 V _{DD}	216 DQ47	/CAS	Column Address Strobe
7 DQS0	37 DQ27	67 V _{REFCA}	97 DQ43	127 V _{SS}	157 V _{SS}	187 /EVENT	217 V _{SS}	/RAS	Row Address Strobe
8 V _{SS}	38 V _{SS}	68 PAR _{IN}	98 V _{SS}	128 DQ6	158 CB4	188 A0	218 DQ52	/S[3:0]	Chip Selects
9 DQ2	39 CB0	69 VDD	99 DQ48	129 DQ7	159 CB5	189 V _{DD}	219 DQ53	/WE	Write Enable
10 DQ3	40 CB1	70 A10/AP	100 DQ49	130 V _{SS}	160 V _{SS}	190 BA1	220 V _{SS}	A[15:0]	Address Inputs
11 V _{SS}	41 V _{SS}	71 BA0	101 V _{SS}	131 DQ12	161 DQS17	191 V _{DD}	221 DQS15	BA[2:0]	Bank Addresses
12 DQ8	42 /DQS8	72 V _{DD}	102 /DQS6	132 DQ13	162 /DQS17	192 /RAS	222 /DQS15	ODT[1:0]	On Die Termination Inputs
13 DQ9	43 DQS8	73 /WE	103 DQS6	133 V _{SS}	163 V _{SS}	193 /S0	223 V _{SS}	SA[2:0]	SPD Address
14 V _{SS}	44 V _{SS}	74 /CAS	104 V _{SS}	134 DQS10	164 CB6	194 V _{DD}	224 DQ54	SCL	SPD Clock Input
15 /DQS1	45 CB2	75 V _{DD}	105 DQ50	135 /DQS10	165 CB7	195 ODT0	225 DQ55	SDA	SPD Data Input/Output
16 DQS1	46 CB3	76 /S1	106 DQ51	136 V _{SS}	166 V _{SS}	196 A13	226 V _{SS}	/EVENT	Temperature Sensing
17 V _{SS}	47 V _{SS}	77 ODT1	107 V _{SS}	137 DQ14	167 NC (TEST)	197 V _{DD}	227 DQ60	/RESET	Reset for register and DRAMs
18 DQ10	48 V _{TT}	78 V _{DD}	108 DQ56	138 DQ15	168 /RESET	198 /S3, NC	228 DQ61	PAR _{IN}	Parity bit for Addr/Ctrl
19 DQ11	49 V _{TT}	79 /S2, NC	109 DQ57	139 V _{SS}	169 CKE1	199 V _{SS}	229 V _{SS}	/ERR _{OUT}	Error bit for Parity Error
20 V _{SS}	50 CKE0	80 V _{SS}	110 V _{SS}	140 DQ20	170 V _{DD}	200 DQ36	230 DQS16	A12/BC	Combination input: Addr12/Burst Chop
21 DQ16	51 V _{DD}	81 DQ32	111 /DQS7	141 DQ21	171 A15	201 DQ37	231 /DQS16	A10/AP	Combination input: Addr10/Auto-precharge
22 DQ17	52 BA2	82 DQ33	112 DQS7	142 V _{SS}	172 A14	202 V _{SS}	232 V _{SS}	V _{SS}	Ground
23 V _{SS}	53 /ERR _{OUT}	83 V _{SS}	113 V _{SS}	143 DQS11	173 V _{DD}	203 DQS13	233 DQ62	V _{DD}	Power
24 /DQS2	54 V _{DD}	84 /DQS4	114 DQ58	144 /DQS11	174 A12/BC	204 /DQS13	234 DQ63	V _{DDSPD}	SPD EEPROM Power
25 DQS2	55 A11	85 DQS4	115 DQ59	145 V _{SS}	175 A9	205 V _{SS}	235 V _{SS}	V _{REFDQ}	Reference Voltage for DQ's
26 V _{SS}	56 A7	86 V _{SS}	116 V _{SS}	146 DQ22	176 V _{DD}	206 DQ38	236 V _{DDSPD}	V _{REFCA}	Reference Voltage for CA
27 DQ18	57 V _{DD}	87 DQ34	117 SA0	147 DQ23	177 A8	207 DQ39	237 SA1	V _{TT}	Termination Voltage
28 DQ19	58 A5	88 DQ35	118 SCL	148 V _{SS}	178 A6	208 V _{SS}	238 SDA	NC	No Connection
29 V _{SS}	59 A4	89 V _{SS}	119 SA2	149 DQ28	179 V _{DD}	209 DQ44	239 V _{SS}		* not used
30 DQ24	60 V _{DD}	90 DQ40	120 V _{TT}	150 DQ29	180 A3	210 DQ45	240 V _{TT}		

Front view

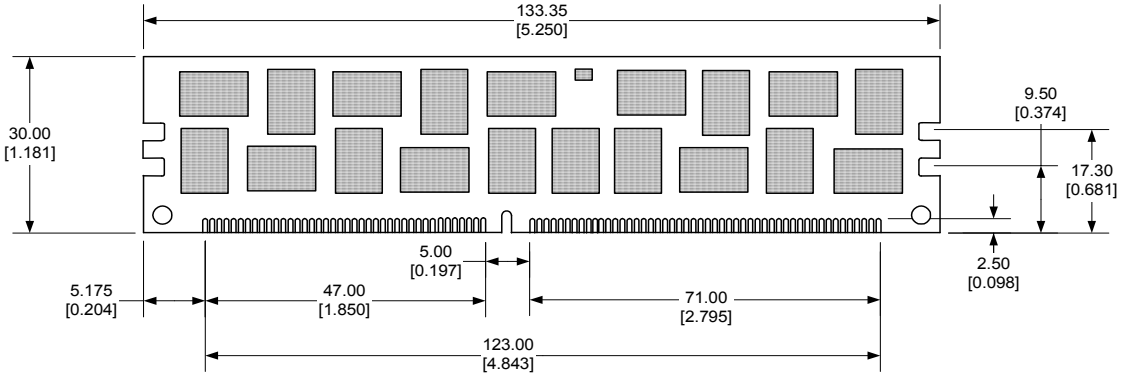

Back view

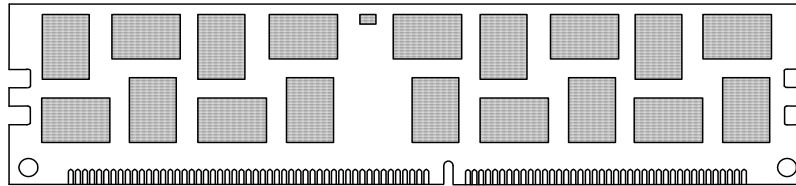

Side view

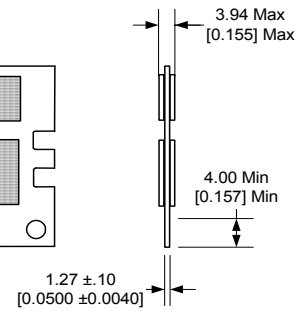

Notes

Tolerances on all dimensions except where otherwise indicated are ± 0.13 (.005).

All dimensions are expressed: millimeters [inches]

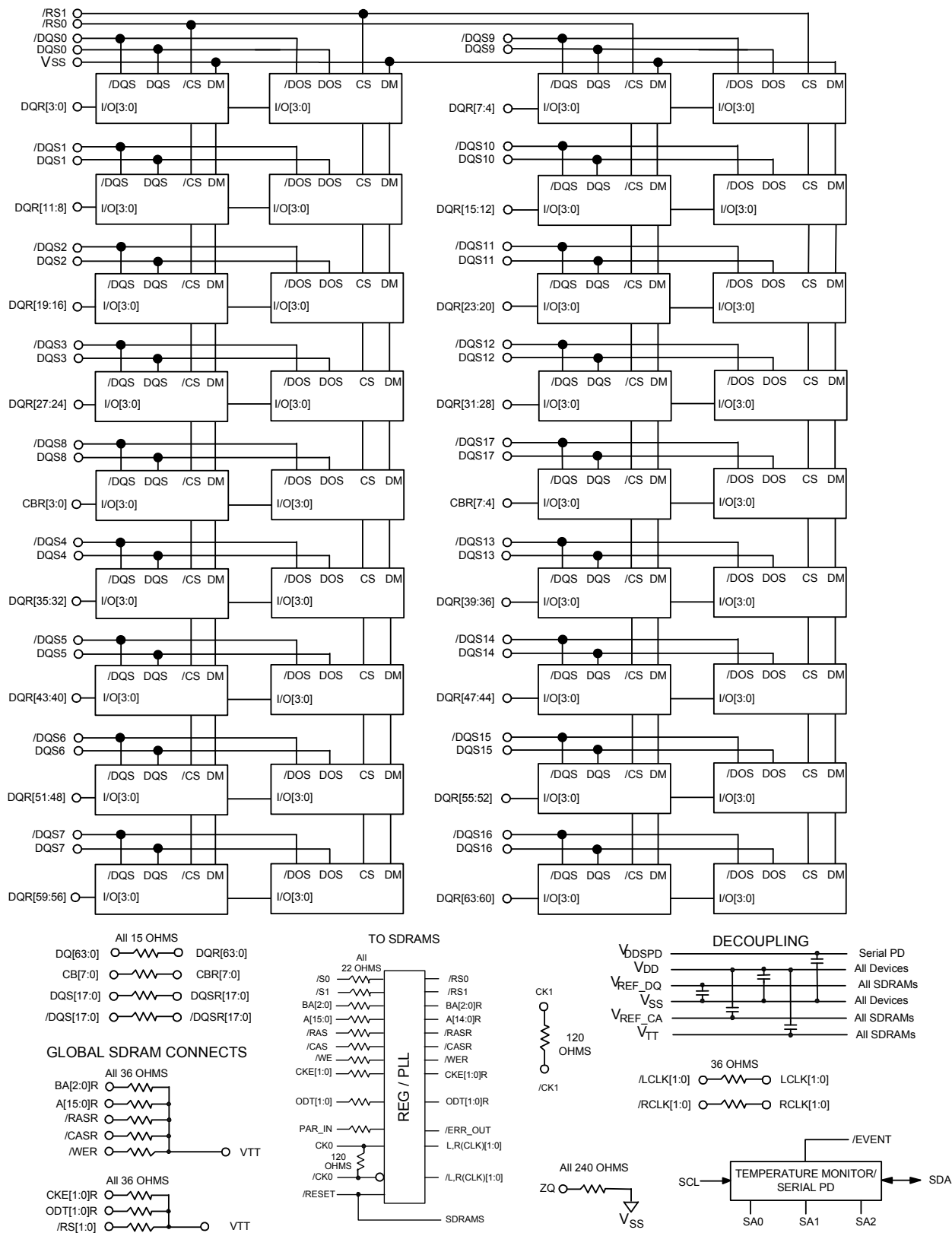

Absolute Maximum Ratings

(Note: Operation at or above Absolute Maximum Ratings can adversely affect module reliability.)

PARAMETER	Symbol	Minimum	Maximum	Unit
Temperature, non-Operating	$T_{STORAGE}$	-55	100	C
Ambient Temperature, Operating	T_A	0	70	C
DRAM Case Temperature, Operating	T_{CASE}	0	95	C
Voltage on V_{DD} relative to V_{SS}	V_{DD}	-0.4	1.975	V
Voltage on Any Pin relative to V_{SS}	V_{IN}, V_{OUT}	-0.4	1.975	V

Notes:

DRAM Operating Case Temperature above 85C requires 2X refresh.

Recommended DC Operating Conditions ($T_A = 0$ to 70 C, Voltage referenced to $V_{SS} = 0$ V)

PARAMETER	Symbol	Minimum	Typical	Maximum	Unit	Note
Power Supply Voltage	V_{DD}	1.425	1.5	1.575	V	
SPD EEPROM Voltage	V_{DDSPD}	3.0	3.3	3.6	V	
I/O Reference Voltage	V_{REFDQ}	0.49 V_{DD}	0.50 V_{DD}	0.51 V_{DD}	V	1
I/O Reference Voltage	V_{REFCA}	0.49 V_{DD}	0.50 V_{DD}	0.51 V_{DD}	V	1

Notes:

1) The value of V_{REF} is expected to equal one-half V_{DD} and to track variations in the V_{DD} DC level. Peak-to-peak noise on V_{REF} may not exceed $\pm 1\%$ of its DC value.

DC Input Logic Levels, Single-Ended ($T_A = 0$ to 70 C, Voltage referenced to $V_{SS} = 0$ V)

PARAMETER	Symbol	Minimum	Maximum	Unit
Logical High (Logic 1)	$V_{IH(DC)}$	$V_{REF} + 0.1$	V_{DD}	V
Logical Low (Logic 0)	$V_{IL(DC)}$	V_{SS}	$V_{REF} - 0.1$	V

AC Input Logic Levels, Single-Ended ($T_A = 0$ to 70 C, Voltage referenced to $V_{SS} = 0$ V)

PARAMETER	Symbol	Minimum	Maximum	Unit
Logical High (Logic 1)	$V_{IH(AC)}$	$V_{REF} + 0.175$	-	V
Logical Low (Logic 0)	$V_{IL(AC)}$	-	$V_{REF} - 0.175$	V

Differential Input Logic Levels ($T_A = 0$ to 70 C, Voltage referenced to $V_{SS} = 0$ V)

PARAMETER	Symbol	Minimum	Maximum	Unit
Differential Input Logic High	$V_{IH,DIFF}$	+0.200	DC: V_{DD} AC: $V_{DD}+0.4$	V
Differential Input Logic Low	$V_{IL,DIFF}$	DC: V_{SS} AC: $V_{SS}-0.4$	-0.200	V
Differential Input Cross Point Voltage relative to $V_{DD}/2$	V_{IX}	- 0.150	+ 0.150	V

Capacitance ($T_A = 25$ C, $f = 100$ MHz)

PARAMETER	Pin	Symbol	Minimum	Maximum	Unit
Input Capacitance, Clock	CK0, /CK0	C_{CK}	1.5	2.5	pF
Input Capacitance, Address	BA[2:0], A[15:0], /RAS, /CAS, /WE	C_I	1.5	2.5	pF
Input Capacitance Control	/S[1:0], CKE[1:0], ODT[1:0]	C_I	1.5	2.5	pF
Input/Output Capacitance	DQ[63:0], CB[7:0] DQS[17:0], /DQS[17:0].	C_{IO}	3	5	pF

DC Characteristics ($T_A = 0$ to 70 C, Voltage referenced to $V_{SS} = 0$ V)

PARAMETER	Symbol	Minimum	Maximum	Unit	Note
Input Leakage Current (Any input 0 V < V_{IN} < V_{DD})	I_{IL}	-18	+18	μ A	1,2
Output Leakage Current (0 V < V_{OUT} < V_{DDQ})	I_{OL}	-10	+10	μ A	2,3

Notes:

- 1) All other pins not under test = 0 V
- 2) Values are shown per pin
- 3) DQ, DQS, DQS and ODT are disabled

I_{DD} Specifications and Conditions (T_A = 0 to 70 C, Voltage referenced to V_{SS} = 0 V)

PARAMETER	Symbol	Test Condition	Max Value	Unit
Operating One Bank Active-Precharge Current	I _{DD0} *	Operating current : One bank ACTIVATE-to-PRECHARGE	1890	mA
Operating One Bank Active-Read-Precharge Current	I _{DD1} *	Operating current : One bank ACTIVATE-to-READ-to-PRECHARGE	2070	mA
Precharge Power-Down Current	I _{DD2P} **	Precharge power down current: (Slow exit)	1062	mA
Precharge Power-Down Current	I _{DD2P} **	Precharge power down current: (Fast exit)	1170	mA
Precharge Standby Current	I _{DD2N} **	Precharge standby current	1410	mA
Active Power-Down Current	I _{DD3P} **	Active power-down current	1350	mA
Active Standby Current	I _{DD3N} **	Active standby current	1940	mA
Operating Burst Write Current	I _{DD4W} *	Burst write operating current	2620	mA
Operating Burst Read Current	I _{DD4R} *	Burst read operating current	2340	mA
Burst Refresh Current	I _{DD5B} **	Refresh current	3200	mA
Self Refresh Current	I _{DD6} **	Self-refresh temperature current: MAX T _c = 85°C	462	mA
Operating Bank Interleave Read Current	I _{DD7} *	All bank interleaved read current	3420	mA

* One module rank in this operation, the rest in IDD2P slow exit.

** All module ranks in this operation.

AC Operating Conditions

PARAMETER	Symbol	Min	Max	Unit
Internal read command to first data	t_{AA}	13.125	20	ns
CAS-to-CAS Command Delay	t_{CCD}	4	-	t_{CK}
Clock High Level Width	$t_{CH(avg)}$	0.47	0.53	t_{CK}
Clock Cycle Time	t_{CK}	1.25	2.500	ns
Clock Low Level Width	$t_{CL(avg)}$	0.47	0.53	t_{CK}
Data Input Hold Time after DQS Strobe	t_{DH}	45	-	ps
DQ Input Pulse Width	t_{DIPW}	360	-	ps
DQS Output Access Time from Clock	t_{DQSCK}	-225	+225	ps
Write DQS High Level Width	t_{DQSH}	0.45	0.55	$t_{CK(avg)}$
Write DQS Low Level Width	t_{DQSL}	0.45	0.55	$t_{CK(avg)}$
DQS-Out Edge to Data-Out Edge Skew	t_{DQSQ}	-	100	ps
Data Input Setup Time Before DQS Strobe	t_{DS}	10	-	ps
DQS Falling Edge from Clock, Hold Time	t_{DSH}	0.2	-	$t_{CK(avg)}$
DQS Falling Edge to Clock, Setup Time	t_{DSS}	0.2	-	$t_{CK(avg)}$
Clock Half Period	t_{HP}	minimum of t_{CH} or t_{CL}	-	ns
Address and Command Hold Time after Clock	t_{IH}	120	-	ps
Address and Command Setup Time before Clock	t_{IS}	45	-	ps
Load Mode Command Cycle Time	t_{MRD}	4	-	t_{CK}
DQ-to-DQS Hold	t_{QH}	0.38	-	$t_{CK(avg)}$
Active-to-Precharge Time	t_{RAS}	35	$9 \cdot t_{REFI}$	ns
Active-to-Active / Auto Refresh Time	t_{RC}	49.125	-	ns
RAS-to-CAS Delay	t_{RCD}	13.125	-	ns
Average Periodic Refresh Interval $0^{\circ}C \leq T_{CASE} < 85^{\circ}C$	t_{REFI}	-	7.8	μs
Average Periodic Refresh Interval $0^{\circ}C \leq T_{CASE} < 95^{\circ}C$	t_{REFI}	-	3.9	μs
Auto Refresh Row Cycle Time	t_{RFC}	160	-	ns
Row Precharge Time	t_{RP}	13.125	-	ns
Read DQS Preamble Time	t_{RPRE}	0.9	Note-1	$t_{CK(avg)}$
Read DQS Postamble Time	t_{RPST}	0.3	Note-2	$t_{CK(avg)}$
Row Active to Row Active Delay	t_{RRD}	Max(4nCK, 6ns)	-	ns
Internal Read to Precharge Command Delay	t_{RTP}	Max(4nCK, 7.5ns)	-	ns
Write DQS Preamble Setup Time	t_{WPRE}	0.9	-	$t_{CK(avg)}$
Write DQS Postamble Time	t_{WPST}	0.3	-	$t_{CK(avg)}$
Write Recovery Time	t_{WR}	15	-	ns
Internal Write to Read Command Delay	t_{WTR}	Max(4nCK, 7.5ns)	-	ns

Notes:

1. The maximum preamble is bound by $t_{LZDQS}(\min)$
2. The maximum postamble is bound by $t_{HZDQS}(\max)$

SERIAL PRESENSE DETECT

Byte#	Function.	Value	Hex
0	Number of Bytes Used / Number of Bytes in SPD Device / CRC Coverage.		0x92
	Bit 3 ~ Bit 0. SPD Bytes Used -	176	
	Bit 6 ~ Bit 4. SPD Bytes Total -	256	
	Bit 7. CRC Coverage -	Bytes 0-116	
1	SPD Revision.	Rev. 1.1	0x11
2	Key Byte / DRAM Device Type.	DDR3 SDRAM	0x0B
3	Key Byte / Module Type.		0x01
	Bit 3 ~ Bit 0. Module Type -	RDIMM	
	Bit 7 ~ Bit 4. Reserved -	0	
4	SDRAM Density and Banks.		0x03
	Bit 3 ~ Bit 0. Total SDRAM capacity, in megabits -	2Gb	
	Bit 6 ~ Bit 4. Bank Address Bits -	8 banks	
	Bit 7. Reserved -	0	
5	SDRAM Addressing.		0x1A
	Bit 2 ~ Bit 0. Column Address Bits -	11	
	Bit 5 ~ Bit 3. Row Address Bits -	15	
	Bit 7, 6. Reserved	0	
6	Module Nominal Voltage, VDD.		0x00
	Bit 0. NOT 1.5 V operable -		
	Bit 1. 1.35 V operable -		
	Bit 2. 1.2X V operable -		
	Bit 3. Reserved -		
	Bit 4. Reserved -		
	Bit 5. Reserved -		
	Bit 6. Reserved -		
Bit 7. Reserved -			
7	Module Organization.		0x08
	Bit 2 ~ Bit 0. SDRAM Device Width -	4-Bits	
	Bit 5 ~ Bit 3. Number of Ranks -	2-Rank	
	Bit 7, 6. Reserved	0	
8	Module Memory Bus Width.		0x0B
	Bit 2 ~ Bit 0. Primary bus width, in bits -	64-Bits	
	Bit 4, Bit 3. Bus width extension, in bits -	8-Bits	
	Bit 7 ~ Bit 5. Reserved -	0	
9	Fine Timebase (FTB) Dividend / Divisor.		0x11
	Bit 3 ~ Bit 0. Fine Timebase (FTB) Divisor	1	
	Bit 7 ~ Bit 4. Fine Timebase (FTB) Dividend	1	
10	Medium Timebase (MTB) Dividend.	1 (MTB = 0.125ns)	0x01
11	Medium Timebase (MTB) Divisor.	8 (MTB = 0.125ns)	0x08

12	SDRAM Minimum Cycle Time (tCKmin).	1.25ns	0x0A
13	Reserved.	UNUSED	0x00
14	CAS Latencies Supported, Least Significant Byte.		0xFC
	Bit 0. CL = 4 -		
	Bit 1. CL = 5 -		
	Bit 2. CL = 6 -	X	
	Bit 3. CL = 7 -	X	
	Bit 4. CL = 8 -	X	
	Bit 5. CL = 9 -	X	
	Bit 6. CL = 10 -	X	
Bit 7. CL = 11 -	X		
15	CAS Latencies Supported, Most Significant Byte.		0x00
	Bit 0. CL = 12 -		
	Bit 1. CL = 13 -		
	Bit 2. CL = 14 -		
	Bit 3. CL = 15 -		
	Bit 4. CL = 16 -		
	Bit 5. CL = 17 -		
	Bit 6. CL = 18 -		
Bit 7. Reserved.			
16	Minimum CAS Latency Time (tAamin).	13.125ns	0x69
17	Minimum Write Recovery Time (tWRmin).	15.0ns	0x78
18	Minimum RAS# to CAS# Delay Time (tRCDmin).	13.125ns	0x69
19	Minimum Row Active to Row Active Delay Time (tRRDmin).	6.0ns	0x30
20	Minimum Row Precharge Delay Time (tRPmin).	13.125ns	0x69
21	Upper Nibbles for tRAS and tRC.		0x11
	Bit 3 ~ Bit 0. tRAS Most Significant Nibble -	1	
	Bit 7 ~ Bit 4. tRC Most Significant Nibble -	1	
22	Minimum Active to Precharge Delay Time (tRASmin), Least Significant Byte.	35.0ns	0x18
23	Minimum Active to Active/Refresh Delay Time (tRCmin), Least Significant Byte.	48.125ns	0x81
24	Minimum Refresh Recovery Delay Time (tRFCmin), Least Significant Byte.	160.0ns	0x00
25	Minimum Refresh Recovery Delay Time (tRFCmin), Most Significant Byte.	160.0ns	0x05
26	Minimum Internal Write to Read Command Delay Time (tWTRmin).	7.5ns	0x3C
27	Minimum Internal Read to Precharge Command Delay Time (tRTPmin).	7.5ns	0x3C
28	Upper Nibble for tFAW.		0x00
	Bit 3 ~ Bit 0. tFAW Most Significant Nibble -	0	
	Bit 7 ~ Bit 4. Reserved -	0	
29	Minimum Four Activate Window Delay Time (tFAWmin), Least Significant Byte.	30.0ns	0xF0

DTM64378C

8GB - 240-Pin 2Rx4 Registered ECC DDR3 DIMM

30	SDRAM Optional Features.		0x83
	Bit 0. RZQ / 6 -	X	
	Bit 1. RZQ / 7 -	X	
	Bit 2. Reserved -		
	Bit 3. Reserved -		
	Bit 4. Reserved -		
	Bit 5. Reserved -		
	Bit 6. Reserved -		
31	SDRAM Drivers Supported.		0x05
	Extended Temperature Range -	X	
	Extended Temperature Refresh Rate -		
	Auto Self Refresh (ASR) -	X	
	On-die Thermal Sensor (ODTS) Readout -		
	Reserved -		
	Reserved -		
	Reserved -		
32	Module Thermal Sensor.		0x80
	Bit 6 ~ Bit 0. Thermal Sensor Accuracy -	0	
	Bit 7. Thermal Sensor -	With TS	
33	SDRAM Device Type.		0x00
	Bit 1 ~ Bit 0. Signal Loading -	Not specified	
	Bit 3 ~ Bit 2. Reserved. 0-Undefined -	0	
	Bit 6 ~ Bit 4. Die Count. -	Not specified	
	Bit 7. SDRAM Device Type -	Std Mono	
34	Fine Offset for SDRAM Minimum Cycle Time (tCKmin) -	UNUSED	0x00
35	Fine Offset for Minimum CAS Latency Time (tAAmin) -	UNUSED	0x00
36	Fine Offset for Minimum RAS# to CAS# Delay Time (tRCDmin) -	UNUSED	0x00
37	Minimum Row Precharge Delay Time (tRPmin) -	UNUSED	0x00
38	Fine Offset for Minimum Active to Active/Refresh Delay Time (tRCmin) -	UNUSED	0x00
39-59	Reserved	UNUSED	0x00
60	Module Nominal Height.		0x0F
	Bit 4 ~ Bit 0. Module Nominal Height max, in mm -	29<h<=30	
	Bit 7 ~ Bit5. Reserved -	0	
61	Module Maximum Thickness.		0x11
	Bit 3 ~ Bit 0. Front, in mm (baseline thickness = 1 mm) -	1<th<=2	
	Bit 7 ~ Bit 4. Back, in mm (baseline thickness = 1 mm) -	1<th<=2	

62	Reference Raw Card Used.		0x44
	Bit 4 ~ Bit 0. Reference Raw Card - R/C E		
	Bit 6, Bit 5. Reference Raw Card Revision - Rev.2		
	Bit 7. Reserved - A-AL		
63	(Registered) DIMM Module Attributes.		0x09
	Bit 1 ~ Bit 0. # of Registers used on RDIMM - 1 Register		
	Bit 3 ~ Bit 2. # of Rows of DRAMs on RDIMM - 2 Rows		
	Bit 7 ~ Bit 4. Reserved - 0		
64	RDIMM Thermal Heat Spreader Solution.		0x00
	Bit 6 ~ Bit 0. Heat Spreader Thermal Characteristics - 0		
	Bit 7. Heat Spreader Solution - No HS		
65	Register Manufacturer ID Code, Least Significant Byte (Optional).	Not recognized	0x00
66	Register Manufacturer ID Code, Most Significant Byte (Optional).	Not recognized	0x00
67	Register Revision Number (Optional).	ÿ	0xFF
68	Register Type.		0x00
	Bit[2-0] Support Device - SSTE32882		
	Bit[7-3] Reserved - 0		
69	[SSTE32882]: RC1 (MS Nibble) / RC0 (LS Nibble)	UNUSED	0x00
70	[SSTE32882]: RC3 (MS Nibble) / RC2 (LS Nibble) - Drive Strength, Command/Address.		0x50
	Bit 1, Bit 0. RC2/DA3,4 Value.- RESERVED		
	Bit 3, Bit 2. RC2/DBA0,1 Value - RESERVED		
	Bit 5, Bit 4. RC3/DA4,3 value, Command/Address A Outputs - Moderate		
	Bit 7, Bit 6. RC3/DBA0,1 value, Command/Address B Outputs - Moderate		
71	[SSTE32882]: RC5 (MS Nibble) / RC4 (LS Nibble) - Drive Strength, Control and Clock.		0x55
	Bit 1, Bit 0. RC4/DA3,4 Control Signals, A Outputs.- Moderate		
	Bit 3, Bit 2. RC4/DBA0,1 Control Signals, B Outputs - Moderate		
	Bit 5, Bit 4. RC5/DA4,3 value, Y1/Y1# and Y3/Y3# Clock Outputs - Moderate		
	Bit 7, Bit 6. RC5/DBA0,1 value, Y0/Y0# and Y2/Y2# Clock Outputs - Moderate		
72	[SSTE32882]: RC7 (MS Nibble) / RC6 (LS Nibble).	UNUSED	0x00
73	[SSTE32882]: RC9 (MS Nibble) / RC8 (LS Nibble).	UNUSED	0x00
74	[SSTE32882]: RC11 (MS Nibble) / RC10 (LS Nibble).	UNUSED	0x00
75	[SSTE32882]: RC13 (MS Nibble) / RC12 (LS Nibble).	UNUSED	0x00
76	[SSTE32882]: RC15 (MS Nibble) / RC14 (LS Nibble).	UNUSED	0x00
77-116	Module-Specific Section		UNUSED 0x00
117	Module Manufacturer ID Code, Least Significant Byte	DATARAM	0x01
118	Module Manufacturer ID Code, Most Significant Byte	DATARAM	0x91
119	Module Manufacturing Location		0x00

120,121	Module Manufacturing Date		0x00
122-125	Module Serial Number		0x23
126	Cyclical Redundancy Code (CRC).	CRC	0x6D
127	Cyclical Redundancy Code (CRC).	CRC	0x2C
128-131	Module Part Number		0x20
132	Module Part Number	D	0x44
133	Module Part Number	A	0x41
134	Module Part Number	T	0x54
135	Module Part Number	A	0x41
136	Module Part Number	R	0x52
137	Module Part Number	A	0x41
138	Module Part Number	M	0x4D
139	Module Part Number		0x20
140	Module Part Number	6	0x36
141	Module Part Number	4	0x34
142	Module Part Number	3	0x33
143	Module Part Number	7	0x37
144	Module Part Number	8	0x38
145	Module Part Number		0x20
146,147	Module Revision Code	UNUSED	0x00
148	DRAM Manufacturer ID Code, Least Significant Byte	Not recognized	0x00
149	DRAM Manufacturer ID Code, Most Significant Byte	Not recognized	0x00
150-175	Manufacturer's Specific Data	UNUSED	0x00
176-255	Open for customer use	UNUSED	0x00

Note: Serial Presence Detect shown for reference only. Some bytes value may vary.



DTM64378C

8GB - 240-Pin 2Rx4 Registered ECC DDR3 DIMM



DATARAM CORPORATION, USA Corporate Headquarters, P.O. Box 7528, Princeton, NJ 08543-7528;
Voice: 609-799-0071, Fax: 609-799-6734; www.dataram.com

All rights reserved.

The information contained in this document has been carefully checked and is believed to be reliable. However, Dataram assumes no responsibility for inaccuracies.

The information contained in this document does not convey any license under the copyrights, patent rights or trademarks claimed and owned by Dataram.

No part of this publication may be copied or reproduced in any form or by any means, or transferred to any third party without prior written consent of Dataram.