

Identification

DTM64369D 256Mx72
 2GB 1Rx8 PC3-12800R-11-11-A0

Performance range

Clock / Module Speed / CL-t_{RCD} -t_{RP}

800 MHz / PC3-12800 / 11-11-11
667 MHz / PC3-10600 / 10-10-10
667 MHz / PC3-10600 / 9-9-9
533 MHz / PC3-8500 / 8-8-8
533 MHz / PC3-8500 / 7-7-7
400 MHz / PC3-6400 / 6-6-6

Features

240-pin JEDEC-compliant DIMM, 133.35 mm wide by 30 mm high

Operating Voltage: 1.5V ± 0.075

I/O Type: SSTL_15

On-board I2C temperature sensor with integrated serial presence-detect (SPD) EEPROM.

Data Transfer Rate: 12.8 Gigabytes/sec

Data Bursts: 8 and burst chop 4 mode

ZQ Calibration for Output Driver and On-Die Termination (ODT)

Programmable ODT / Dynamic ODT during Writes

Programmable CAS Latency: 6, 7, 8, 9, 10 and 11

Bi-Directional Differential Data Strobe signals

SDRAM Addressing (Row/Col/Bank): 15/10/3

Fully RoHS Compliant

Description

DTM64369D is a registered 256Mx72 memory module, which conforms to JEDEC's DDR3, PC3-12800 standard. The assembly is a Single-Rank. The Rank is comprised of nine 256Mx8 DDR3-1600 Hynix SDRAMs.

One 2K-bit EEPROM is used for Serial Presence Detect and a combination register/PLL, with Address and Command Parity, is also used.

Both output driver strength and input termination impedance are programmable to maintain signal integrity on the I/O signals in a Fly-by topology.

A thermal sensor accurately monitors the DIMM module and can prevent exceeding the maximum operating temperature of 95C.

Pin Configuration

Pin Description

Front Side				Back Side				Name	Function
1 V _{REFDQ}	31 DQ25	61 A2	91 DQ41	121 V _{SS}	151 V _{SS}	181 A1	211 V _{SS}	CB[7:0]	Data Check Bits
2 V _{SS}	32 V _{SS}	62 V _{DD}	92 V _{SS}	122 DQ4	152 DM3	182 V _{DD}	212 DM5	DQ[63:0]	Data Bits
3 DQ0	33 /DQS3	63 CK1*	93 /DQS5	123 DQ5	153 /TDQS12	183 V _{DD}	213 /TDQS14	DQS[8:0], /DQS[8:0]	Differential Data Strobes
4 DQ1	34 DQS3	64 /CK1*	94 DQS5	124 V _{SS}	154 V _{SS}	184 CK0	214 V _{SS}	DM[8:0]	Data Mask
5 V _{SS}	35 V _{SS}	65 V _{DD}	95 V _{SS}	125 DM0	155 DQ30	185 /CK0	215 DQ46	/TDQS[17:9]	Termination strobes
6 /DQS0	36 DQ26	66 V _{DD}	96 DQ42	126 /TDQS9	156 DQ31	186 V _{DD}	216 DQ47	CK[1:0], /CK[1:0]	Differential Clock Inputs
7 DQS0	37 DQ27	67 V _{REFCA}	97 DQ43	127 V _{SS}	157 V _{SS}	187 /EVENT	217 V _{SS}	CKE[1:0]	Clock Enables
8 V _{SS}	38 V _{SS}	68 P _{ARL} _IN	98 V _{SS}	128 DQ6	158 CB4	188 A0	218 DQ52	/CAS	Column Address Strobe
9 DQ2	39 CB0	69 V _{DD}	99 DQ48	129 DQ7	159 CB5	189 V _{DD}	219 DQ53	/RAS	Row Address Strobe
10 DQ3	40 CB1	70 A10/AP	100 DQ49	130 V _{SS}	160 V _{SS}	190 BA1	220 V _{SS}	/S[3:0]	Chip Selects
11 V _{SS}	41 V _{SS}	71 BA0	101 V _{SS}	131 DQ12	161 DM8	191 V _{DD}	221 DM6	/WE	Write Enable
12 DQ8	42 /DQS8	72 V _{DD}	102 /DQS6	132 DQ13	162 /TDQS17	192 /RAS	222 /TDQS15	A[15:0]	Address Inputs
13 DQ9	43 DQS8	73 /WE	103 DQS6	133 V _{SS}	163 V _{SS}	193 /S0	223 V _{SS}	BA[2:0]	Bank Addresses
14 V _{SS}	44 V _{SS}	74 /CAS	104 V _{SS}	134 DM1	164 CB6	194 V _{DD}	224 DQ54	ODT[1:0]	On Die Termination Inputs
15 /DQS1	45 CB2	75 V _{DD}	105 DQ50	135 /TDQS10	165 CB7	195 OD70	225 DQ55	SA[2:0]	SPD Address
16 DQS1	46 CB3	76 /S1*	106 DQ51	136 V _{SS}	166 V _{SS}	196 A13	226 V _{SS}	SCL	SPD Clock Input
17 V _{SS}	47 V _{SS}	77 ODT1*	107 V _{SS}	137 DQ14	167 NC (TEST)	197 V _{DD}	227 DQ60	SDA	SPD Data Input/Output
18 DQ10	48 V _{TT}	78 V _{DD}	108 DQ56	138 DQ15	168 /RESET	198 /S3, NC*	228 DQ61	/EVENT	Temperature Sensing
19 DQ11	49 V _{TT}	79 /S2, NC*	109 DQ57	139 V _{SS}	169 CKE1*	199 V _{SS}	229 V _{SS}	/RESET	Reset for register and DRAMs
20 V _{SS}	50 CKE0	80 V _{SS}	110 V _{SS}	140 DQ20	170 V _{DD}	200 DQ36	230 DM7	PAR_IN	Parity bit for Addr/Ctrl
21 DQ16	51 V _{DD}	81 DQ32	111 /DQS7	141 DQ21	171 A15	201 DQ37	231 /TDQS16	/ERR_OUT	Error bit for Parity Error
22 DQ17	52 BA2	82 DQ33	112 DQS7	142 V _{SS}	172 A14	202 V _{SS}	232 V _{SS}	A12/BC	Combination input: Addr12/Burst Chop
23 V _{SS}	53 /E _{RR} _OUT	83 V _{SS}	113 V _{SS}	143 DM2	173 V _{DD}	203 DM4	233 DQ62	A10/AP	Combination input: Addr10/Auto-precharge
24 /DQS2	54 V _{DD}	84 /DQS4	114 DQ58	144 /TDQS11	174 A12/BC	204 /TDQS13	234 DQ63	V _{SS}	Ground
25 DQS2	55 A11	85 DQS4	115 DQ59	145 V _{SS}	175 A9	205 V _{SS}	235 V _{SS}	V _{DD}	Power
26 V _{SS}	56 A7	86 V _{SS}	116 V _{SS}	146 DQ22	176 V _{DD}	206 DQ38	236 V _{DDSPD}	V _{DDSPD}	SPD EEPROM Power
27 DQ18	57 V _{DD}	87 DQ34	117 SA0	147 DQ23	177 A8	207 DQ39	237 SA1	V _{REFDQ}	Reference Voltage for DQ's
28 DQ19	58 A5	88 DQ35	118 SCL	148 V _{SS}	178 A6	208 V _{SS}	238 SDA	V _{REFCA}	Reference Voltage for CA
29 V _{SS}	59 A4	89 V _{SS}	119 SA2	149 DQ28	179 V _{DD}	209 DQ44	239 V _{SS}	V _{TT}	Termination Voltage
30 DQ24	60 V _{DD}	90 DQ40	120 V _{TT}	150 DQ29	180 A3	210 DQ45	240 V _{TT}	NC	No Connection

* Not used

Front view

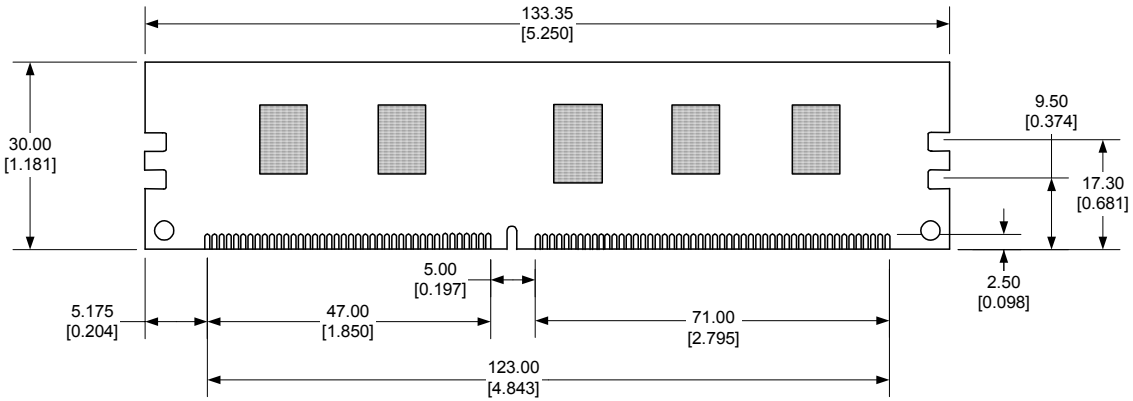

Back view

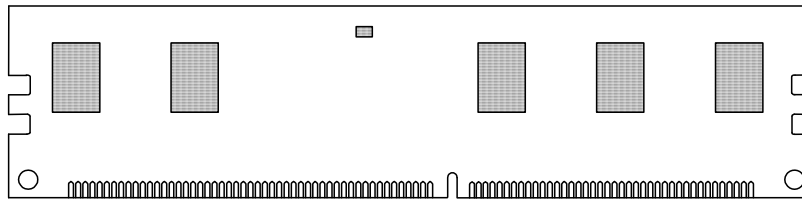

Side view

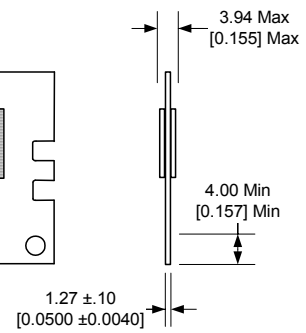

Notes

Tolerances on all dimensions except where otherwise indicated are ±.13 (.005).

All dimensions are expressed: millimeters [inches]

DTM64369D

2GB - 240-Pin 1Rx8 Registered ECC DDR3 DIMM

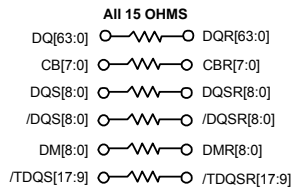
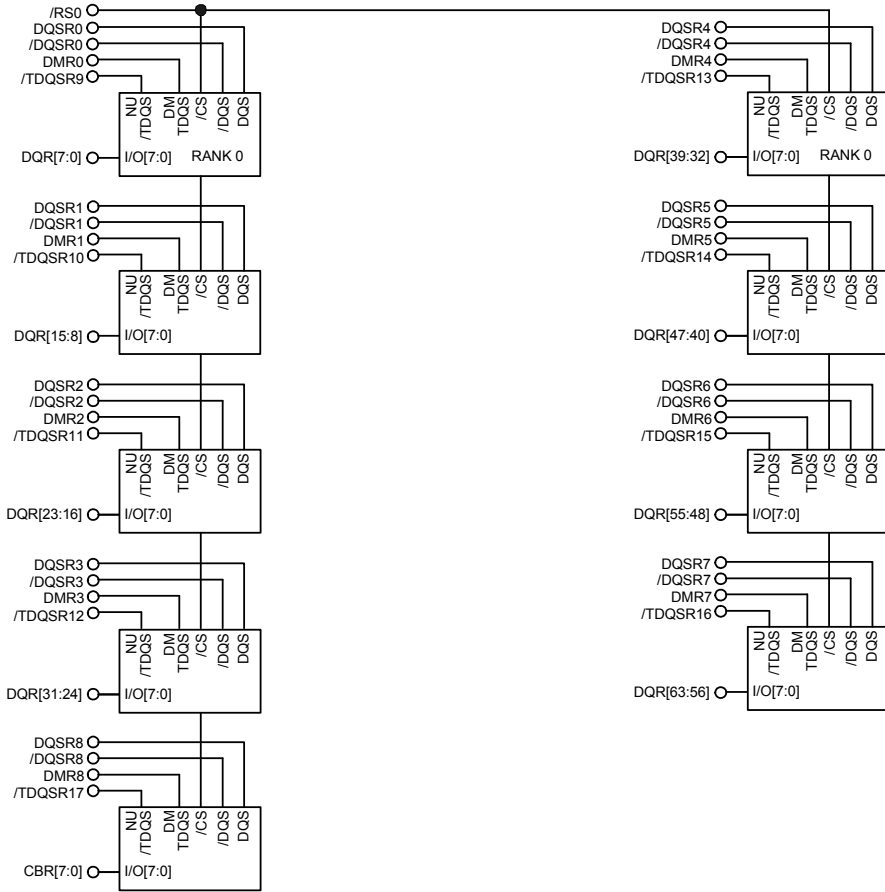

GLOBAL SDRAM CONNECTS

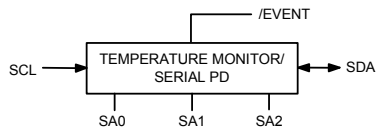
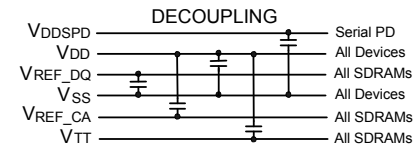
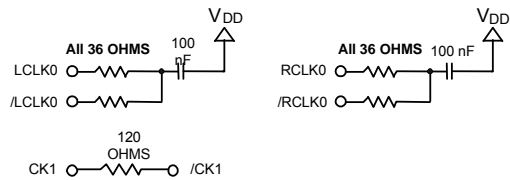
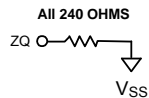
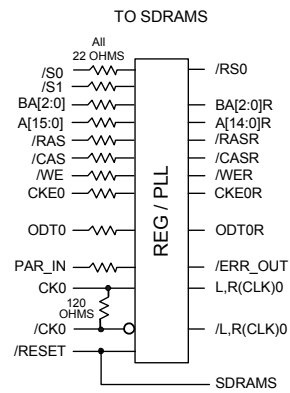
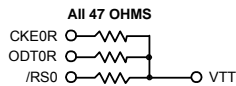
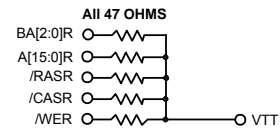

Absolute Maximum Ratings

(Note: Operation at or above Absolute Maximum Ratings can adversely affect module reliability.)

PARAMETER	Symbol	Minimum	Maximum	Unit
Temperature, non-Operating	T _{STORAGE}	-55	100	C
Ambient Temperature, Operating	T _A	0	70	C
DRAM Case Temperature, Operating	T _{CASE}	0	95	C
Voltage on V _{DD} relative to V _{SS}	V _{DD}	-0.4	1.975	V
Voltage on Any Pin relative to V _{SS}	V _{IN} , V _{OUT}	-0.4	1.975	V

Notes:

DRAM Operating Case Temperature above 85C requires 2X refresh.

Recommended DC Operating Conditions (T_A = 0 to 70 C, Voltage referenced to V_{SS} = 0 V)

PARAMETER	Symbol	Minimum	Typical	Maximum	Unit	Note
Power Supply Voltage	V _{DD}	1.425	1.5	1.575	V	
I/O Reference Voltage	V _{REFDQ}	0.49 V _{DD}	0.50 V _{DD}	0.51 V _{DD}	V	1
I/O Reference Voltage	V _{REFCA}	0.49 V _{DD}	0.50 V _{DD}	0.51 V _{DD}	V	1

Notes:

For Reference V_{DD}/2 ± 15 mV. The value of VREF is expected to equal one-half VDD and to track variations in the VDD DC level. Peak-to-peak noise on VREF may not exceed ±1% of its DC value. For Reference: VREF = VDD/2 ± 15 mV.

DC Input Logic Levels, Single-Ended (T_A = 0 to 70 C, Voltage referenced to V_{SS} = 0 V)

PARAMETER	Symbol	Minimum	Maximum	Unit
Logical High (Logic 1)	V _{IH(DC)}	V _{REF} + 0.1	V _{DD}	V
Logical Low (Logic 0)	V _{IL(DC)}	V _{SS}	V _{REF} - 0.1	V

AC Input Logic Levels, Single-Ended (T_A = 0 to 70 C, Voltage referenced to V_{SS} = 0 V)

PARAMETER	Symbol	Minimum	Maximum	Unit
Logical High (Logic 1)	V _{IH(AC)}	V _{REF} + 0.175	-	V
Logical Low (Logic 0)	V _{IL(AC)}	-	V _{REF} - 0.175	V

Differential Input Logic Levels ($T_A = 0$ to 70 C, Voltage referenced to $V_{SS} = 0$ V)

PARAMETER	Symbol	Minimum	Maximum	Unit
Differential Input Logic High	$V_{IH,DIFF}$	+0.200	DC: V_{DD} AC: $V_{DD}+0.4$	V
Differential Input Logic Low	$V_{IL,DIFF}$	DC: V_{SS} AC: $V_{SS}-0.4$	-0.200	V
Differential Input Cross Point Voltage relative to $V_{DD}/2$	V_{IX}	- 0.150	+ 0.150	V

Capacitance ($T_A = 25$ C, $f = 100$ MHz)

PARAMETER	Pin	Symbol	Minimum	Maximum	Unit
Input Capacitance, Clock	CK0, /CK0	C_{CK}	1.5	2.5	pF
Input Capacitance, Address	BA[2:0], A[15:0], /RAS, /CAS, /WE	C_I	1.5	2.5	pF
Input Capacitance Control	/S0, CKE0, ODT0	C_I	1.5	2.5	pF
Input/Output Capacitance	DQ[63:0], CB[7:0] DQS[8:0], /DQS[8:0], DM[8:0], /TDQS[17:9]	C_{IO}	1.5	2.3	pF

DC Characteristics ($T_A = 0$ to 70 C, Voltage referenced to $V_{SS} = 0$ V)

PARAMETER	Symbol	Minimum	Maximum	Unit	Note
Input Leakage Current (Any input 0 V < V_{IN} < V_{DD})	I_{IL}	-18	+18	μ A	1,2
Output Leakage Current (0 V < V_{OUT} < V_{DDQ})	I_{OL}	-10	+10	μ A	2,3

Notes:

- 1) All other pins not under test = 0 V
- 2) Values are shown per pin
- 3) DQ, DQS, /DQS and ODT are disabled

I_{DD} Specifications and Conditions (T_A = 0 to 70 C, Voltage referenced to V_{SS} = 0 V)

PARAMETER	Symbol	Test Condition	Max Value	Unit
Operating One Bank Active-Precharge Current	I _{DD0}	Operating current : One bank ACTIVATE-to-PRECHARGE	315	mA
Operating One Bank Active-Read-Precharge Current	I _{DD1}	Operating current : One bank ACTIVATE-to-READ-to-PRECHARGE	360	mA
Precharge Power-Down Current	I _{DD2P}	Precharge power down current: (Slow exit)	108	mA
Precharge Power-Down Current	I _{DD2P}	Precharge power down current: (Fast exit)	135	mA
Precharge Quiet Standby Current	I _{DD2Q}	Precharge quiet standby current	162	mA
Precharge Standby Current	I _{DD2N}	Precharge standby current	162	mA
Active Power-Down Current	I _{DD3P}	Active power-down current	135	mA
Active Standby Current	I _{DD3N}	Active standby current	207	mA
Operating Burst Write Current	I _{DD4W}	Burst write operating current	765	mA
Operating Burst Read Current	I _{DD4R}	Burst read operating current	765	mA
Burst Refresh Current	I _{DD5}	Refresh current	1440	mA
Self Refresh Current	I _{DD6}	Self-refresh temperature current: MAX T _c = 85°C	108	mA
Operating Bank Interleave Read Current	I _{DD7}	All bank interleaved read current	1170	mA

AC Operating Conditions

PARAMETER	Symbol	Min	Max	Unit
Internal read command to first data	t_{AA}	13.75(13.125)	20	ns
CAS-to-CAS Command Delay	t_{CCD}	4	-	t_{CK}
Clock High Level Width	$t_{CH(avg)}$	0.47	0.53	t_{CK}
Clock Cycle Time	t_{CK}	1.25	2.5	ns
Clock Low Level Width	$t_{CL(avg)}$	0.47	0.53	t_{CK}
Data Input Hold Time after DQS Strobe	t_{DH}	45	-	ps
DQ Input Pulse Width	t_{DIPW}	360	-	ps
DQS Output Access Time from Clock	t_{DQSCK}	-225	+225	ps
Write DQS High Level Width	t_{DQSH}	0.45	0.55	$t_{CK(avg)}$
Write DQS Low Level Width	t_{DQSL}	0.45	0.55	$t_{CK(avg)}$
DQS-Out Edge to Data-Out Edge Skew	t_{DQSQ}	-	100	ps
Data Input Setup Time Before DQS Strobe	t_{DS}	10	-	ps
DQS Falling Edge from Clock, Hold Time	t_{DSH}	0.18	-	$t_{CK(avg)}$
DQS Falling Edge to Clock, Setup Time	t_{DSS}	0.18	-	$t_{CK(avg)}$
Clock Half Period	t_{HP}	minimum of t_{CH} or t_{CL}	-	ns
Address and Command Hold Time after Clock	t_{IH}	120	-	ps
Address and Command Setup Time before Clock	t_{IS}	45	-	ps
Load Mode Command Cycle Time	t_{MRD}	4	-	t_{CK}
DQ-to-DQS Hold	t_{QH}	0.38	-	$t_{CK(avg)}$
Active-to-Precharge Time	t_{RAS}	35	$9 \cdot t_{REFI}$	ns
Active-to-Active / Auto Refresh Time	t_{RC}	48.75(48.125)	-	ns
RAS-to-CAS Delay	t_{RCD}	13.75(13.125)	-	ns
Average Periodic Refresh Interval $0^{\circ}C \leq T_{CASE} < 85^{\circ}C$	t_{REFI}	-	7.8	μs
Average Periodic Refresh Interval $0^{\circ}C \leq T_{CASE} < 95^{\circ}C$	t_{REFI}	-	3.9	μs
Auto Refresh Row Cycle Time	t_{RFC}	160	-	ns
Row Precharge Time	t_{RP}	13.75(13.125)	-	ns
Read DQS Preamble Time	t_{RPRE}	0.9	Note-1	$t_{CK(avg)}$
Read DQS Postamble Time	t_{RPST}	0.3	Note-2	$t_{CK(avg)}$
Row Active to Row Active Delay	t_{RRD}	Max(4nCK, 6ns)	-	ns
Internal Read to Precharge Command Delay	t_{RTP}	Max(4nCK, 7.5ns)	-	ns
Write DQS Preamble Setup Time	t_{WPRE}	0.9	-	$t_{CK(avg)}$
Write DQS Postamble Time	t_{WPST}	0.3	-	$t_{CK(avg)}$
Write Recovery Time	t_{WR}	15	-	ns
Internal Write to Read Command Delay	t_{WTR}	Max(4nCK, 7.5ns)	-	ns

Notes:

- The maximum preamble is bound by $t_{LZDQS}(\min)$.
The maximum postamble is bound by $t_{HZDQS}(\max)$

SERIAL PRESENCE DETECT MATRIX

Byte#	Function.	Value	Hex
0	Number of Bytes Used / Number of Bytes in SPD Device / CRC Coverage.		0x92
	Bit 3 ~ Bit 0. SPD Bytes Used -	176	
	Bit 6 ~ Bit 4. SPD Bytes Total -	256	
	Bit 7. CRC Coverage -	Bytes 0-116	
1	SPD Revision.	Rev. 1.1	0x11
2	Key Byte / DRAM Device Type.	DDR3 SDRAM	0x0B
3	Key Byte / Module Type.		0x01
	Bit 3 ~ Bit 0. Module Type -	RDIMM	
	Bit 7 ~ Bit 4. Reserved -	0	
4	SDRAM Density and Banks.		0x03
	Bit 3 ~ Bit 0. Total SDRAM capacity, in megabits -	2Gb	
	Bit 6 ~ Bit 4. Bank Address Bits -	8 banks	
	Bit 7. Reserved -	0	
5	SDRAM Addressing.		0x19
	Bit 2 ~ Bit 0. Column Address Bits -	10	
	Bit 5 ~ Bit 3. Row Address Bits -	15	
	Bit 7, 6. Reserved	0	
6	Module Nominal Voltage, VDD.		0x00
	Bit 0. NOT 1.5 V operable -		
	Bit 1. 1.35 V operable -		
	Bit 2. 1.2X V operable -		
	Bit 3. Reserved -		
	Bit 4. Reserved -		
	Bit 5. Reserved -		
	Bit 6. Reserved -		
Bit 7. Reserved -			
7	Module Organization.		0x01
	Bit 2 ~ Bit 0. SDRAM Device Width -	8-Bits	
	Bit 5 ~ Bit 3. Number of Ranks -	1-Rank	
	Bit 7, 6. Reserved	0	
8	Module Memory Bus Width.		0x0B
	Bit 2 ~ Bit 0. Primary bus width, in bits -	64-Bits	
	Bit 4, Bit 3. Bus width extension, in bits -	8-Bits	
	Bit 7 ~ Bit 5. Reserved -	0	
9	Fine Timebase (FTB) Dividend / Divisor.		0x11
	Bit 3 ~ Bit 0. Fine Timebase (FTB) Divisor	1	
	Bit 7 ~ Bit 4. Fine Timebase (FTB) Dividend	1	
10	Medium Timebase (MTB) Dividend.	1 (MTB = 0.125ns)	0x01

11	Medium Timebase (MTB) Divisor.	8 (MTB = 0.125ns)	0x08
12	SDRAM Minimum Cycle Time (tCKmin).	1.25ns	0x0A
13	Reserved.	UNUSED	0x00
14	CAS Latencies Supported, Least Significant Byte.		0xFC
	Bit 0. CL = 4 -		
	Bit 1. CL = 5 -		
	Bit 2. CL = 6 - X		
	Bit 3. CL = 7 - X		
	Bit 4. CL = 8 - X		
	Bit 5. CL = 9 - X		
	Bit 6. CL = 10 - X		
Bit 7. CL = 11 - X			
15	CAS Latencies Supported, Most Significant Byte.		0x00
	Bit 0. CL = 12 -		
	Bit 1. CL = 13 -		
	Bit 2. CL = 14 -		
	Bit 3. CL = 15 -		
	Bit 4. CL = 16 -		
	Bit 5. CL = 17 -		
	Bit 6. CL = 18 -		
Bit 7. Reserved.			
16	Minimum CAS Latency Time (tAamin).	13.125ns	0x69
17	Minimum Write Recovery Time (tWRmin).	15.0ns	0x78
18	Minimum RAS# to CAS# Delay Time (tRCDmin).	13.125ns	0x69
19	Minimum Row Active to Row Active Delay Time (tRRDmin).	6.0ns	0x30
20	Minimum Row Precharge Delay Time (tRPmin).	13.125ns	0x69
21	Upper Nibbles for tRAS and tRC.		0x11
	Bit 3 ~ Bit 0. tRAS Most Significant Nibble - 1		
	Bit 7 ~ Bit 4. tRC Most Significant Nibble - 1		
22	Minimum Active to Precharge Delay Time (tRASmin), Least Significant Byte.	35.0ns	0x18
23	Minimum Active to Active/Refresh Delay Time (tRCmin), Least Significant Byte.	48.125ns	0x81
24	Minimum Refresh Recovery Delay Time (tRFCmin), Least Significant Byte.	160.0ns	0x00
25	Minimum Refresh Recovery Delay Time (tRFCmin), Most Significant Byte.	160.0ns	0x05
26	Minimum Internal Write to Read Command Delay Time (tWTRmin).	7.5ns	0x3C
27	Minimum Internal Read to Precharge Command Delay Time (tRTPmin).	7.5ns	0x3C
28	Upper Nibble for tFAW.		0x00
	Bit 3 ~ Bit 0. tFAW Most Significant Nibble - 0		
	Bit 7 ~ Bit 4. Reserved - 0		

29	Minimum Four Activate Window Delay Time (tFAWmin), Least Significant Byte.	30.0ns	0xF0	
30	SDRAM Optional Features.		0x83	
	Bit 0. RZQ / 6 -	X		
	Bit 1. RZQ / 7 -	X		
	Bit 6 ~ Bit 2. Reserved - Bit 7. DLL-Off Mode Support			
31	SDRAM Drivers Supported.		0x01	
	Extended Temperature Range -	X		
	Extended Temperature Refresh Rate -			
	Auto Self Refresh (ASR) -			
	On-die Thermal Sensor (ODTS) Readout -			
	Reserved -			
	Reserved -			
	Reserved -			
32	Module Thermal Sensor.		0x80	
	Bit 6 ~ Bit 0. Thermal Sensor Accuracy -	0		
	Bit 7. Thermal Sensor -	With TS		
33	SDRAM Device Type.		0x00	
	Bit 6 ~ Bit 0. Non-Standard Device Description -	0		
	Bit 7. SDRAM Device Type -	Std Mono		
34-59	Reserved	UNUSED	0x00	
60	Module Nominal Height.		0x0F	
	Bit 4 ~ Bit 0. Module Nominal Height max, in mm -	29<h<=30		
	Bit 7 ~ Bit5. Reserved -	0		
61	Module Maximum Thickness.		0x11	
	Bit 3 ~ Bit 0. Front, in mm (baseline thickness = 1 mm) -	1<th<=2		
	Bit 7 ~ Bit 4. Back, in mm (baseline thickness = 1 mm) -	1<th<=2		
62	Reference Raw Card Used.		0x00	
	Bit 4 ~ Bit 0. Reference Raw Card -	R/C A		
	Bit 6, Bit 5. Reference Raw Card Revision -	Rev.0		
63	Reference Raw Card Used.		0x00	
	Bit 7. Reserved -	0		
	(Registered) DIMM Module Attributes.			0x05
	Bit 1 ~ Bit 0. # of Registers used on RDIMM -	1 Register		
Bit 3 ~ Bit 2. # of Rows of DRAMs on RDIMM -	1 Row			
64	Bit 7 ~ Bit 4. Reserved -		0	
	RDIMM Thermal Heat Spreader Solution.			0x00
	Bit 6 ~ Bit 0. Heat Spreader Thermal Characteristics -	0		
	Bit 7. Heat Spreader Solution -	No HS		
65	Register Manufacturer ID Code, Least Significant Byte (Optional).		0x80	
66	Register Manufacturer ID Code, Most Significant Byte (Optional).		0xB3	

67	Register Revision Number (Optional).		0x63
68	Register Type.		0x00
		Bit[2-0] Support Device - SSTE32882 Bit[7-3] Reserved - 0	
69	[SSTE32882]: RC1 (MS Nibble) / RC0 (LS Nibble)	UNUSED	0x00
70	[SSTE32882]: RC3 (MS Nibble) / RC2 (LS Nibble) - Drive Strength, Command/Address.		0x00
		Bit 1, Bit 0. RC2/DA3,4 Value.- RESERVED	
		Bit 3, Bit 2. RC2/DBA0,1 Value - RESERVED	
		Bit 5, Bit 4. RC3/DA4,3 value, Command/Address A Outputs - Light Bit 7, Bit 6. RC3/DBA0,1 value, Command/Address B Outputs - Light	
71	[SSTE32882]: RC5 (MS Nibble) / RC4 (LS Nibble) - Drive Strength, Control and Clock.		0x00
		Bit 1, Bit 0. RC4/DA3,4 Control Signals, A Outputs.- Light	
		Bit 3, Bit 2. RC4/DBA0,1 Control Signals, B Outputs - Light	
		Bit 5, Bit 4. RC5/DA4,3 value, Y1/Y1# and Y3/Y3# Clock Outputs - Light Bit 7, Bit 6. RC5/DBA0,1 value, Y0/Y0# and Y2/Y2# Clock Outputs - Light	
72	[SSTE32882]: RC7 (MS Nibble) / RC6 (LS Nibble).	UNUSED	0x00
73	[SSTE32882]: RC9 (MS Nibble) / RC8 (LS Nibble).	UNUSED	0x00
74	[SSTE32882]: RC11 (MS Nibble) / RC10 (LS Nibble).	UNUSED	0x00
75	[SSTE32882]: RC13 (MS Nibble) / RC12 (LS Nibble).	UNUSED	0x00
76	[SSTE32882]: RC15 (MS Nibble) / RC14 (LS Nibble).	UNUSED	0x00
77-112	Module-Specific Section	UNUSED	0x00
113	Module-Specific Section.	UNUSED	0x00
114-116	Module-Specific Section	UNUSED	0x00
117	Module Manufacturer ID Code, Least Significant Byte		0x80
118	Module Manufacturer ID Code, Most Significant Byte		0xCE
119	Module Manufacturing Location		0x01
120	Module Manufacturing Date		0x11
121	Module Manufacturing Date		0x20
122	Module Serial Number		0x44
123	Module Serial Number		0x22
124	Module Serial Number		0x80
125	Module Serial Number		0xBE
126	Cyclical Redundancy Code (CRC).	CRC	0x67
127	Cyclical Redundancy Code (CRC).	CRC	0x38
128-131	Module Part Number	Space	0x20
132	Module Part Number	D	0x44
133	Module Part Number	A	0x41

DTM64369D

2GB - 240-Pin 1Rx8 Registered ECC DDR3 DIMM

134	Module Part Number	T	0x54
135	Module Part Number	A	0x41
136	Module Part Number	R	0x52
137	Module Part Number	A	0x41
138	Module Part Number	M	0x4D
139	Module Part Number	Space	0x20
140	Module Part Number	6	0x36
141	Module Part Number	4	0x34
142	Module Part Number	3	0x33
143	Module Part Number	6	0x36
144	Module Part Number	9	0x39
145	Module Part Number	Space	0x20
146, 147	Module Revision Code	UNUSED	0x00
148	DRAM Manufacturer ID Code, Least Significant Byte		0x80
149	DRAM Manufacturer ID Code, Most Significant Byte		0xCE
150-175	Manufacturer's Specific Data	UNUSED	0x00
176-255	Open for customer use	UNUSED	0x00

Bytes 122 – 125 change per DIMM.



DTM64369D

2GB - 240-Pin 1Rx8 Registered ECC DDR3 DIMM



DATARAM CORPORATION, USA Corporate Headquarters, P.O. Box 7528, Princeton, NJ 08543-7528;
Voice: 609-799-0071, Fax: 609-799-6734; www.dataram.com

All rights reserved.

The information contained in this document has been carefully checked and is believed to be reliable. However, Dataram assumes no responsibility for inaccuracies.

The information contained in this document does not convey any license under the copyrights, patent rights or trademarks claimed and owned by Dataram.

No part of this publication may be copied or reproduced in any form or by any means, or transferred to any third party without prior written consent of Dataram.