

DTM63392F

1GB - 240-Pin Registered ECC DDR2 DIMM w/CMD/ADD Parity

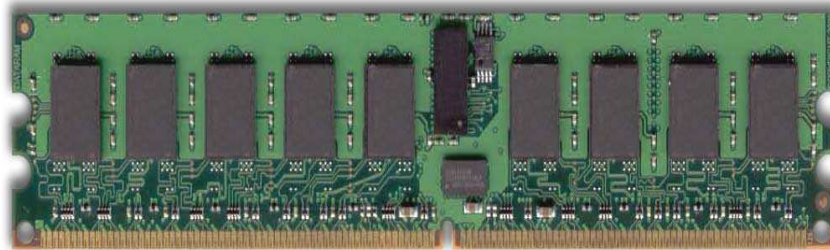

Identification

DTM63392F 128Mx72
1Rx8 PC2-5300P-555-12-F0

Performance range

Clock / Module Speed / CL-t_{RCD} -t_{RP}
333 MHz / PC2-5300 / 5-5-5
266 MHz / PC2-4200 / 4-4-4

Features

- 240-pin JEDEC-compliant Single Rank DIMM
- Operating Voltage: 1.8 V ±0.1
- I/O Type: SSTL_18
- Data Transfer Rate: 5.3 Gigabytes/sec
- Data Bursts: 4 or 8 bits, Sequential or Interleaved ordering
- Error Checking and Correction (ECC) data bits
- Programmable I/O driver strength (OCD)
- Support Address and Control signal parity checking
- Programmable CAS Latency: 4 and 5
- Relative Humidity: 20% - 80% non-condensing
- SDRAM Addressing (Row/Col/Bank): 14/10/3
- Fully ROHS Compliant

Description

DTM63392F is a Registered 128Mx72 memory module which conforms to JEDEC's DDR2, PC2-5300 standard. The assembly is comprised of one Rank of nine 128Mx8 DDR2 Samsung DRAMs, one Register with command/address parity, one Phase-Locked Loop (PLL), and one 2K-bit EEPROM used for Serial Presence Detect.

Both output driver strength and input termination impedance are programmable to maintain signal integrity on the I/O signals. Error Checking and Correction bits are provided to ensure data integrity. In addition, parity is checked for all address and control lines, even those address lines not used by this module.

The eighteen Data Strobe signals may be used either as nine differential pairs, or as eighteen single-ended strobes for use in systems with a mix of x4 and x8 DRAMs.

Pin Configuration

Pin Description

Front Side				Back Side				Name	Function
1 VREF	31 DQ19	61 A4	91 GND	121 GND	151 GND	181 VDD	211 DM5/DQS14	/CAS	Column Address Strobe
2 GND	32 GND	62 VDD	92 /DQS5	122 DQ4	152 DQ28	182 A3	212 /DQS14	/Err_Out	Parity Error Found
3 DQ0	33 DQ24	63 A2	93 DQS5	123 DQ5	153 DQ29	183 A1	213 GND	/RAS	Row Address Strobe
4 DQ1	34 DQ25	64 VDD	94 GND	124 GND	154 GND	184 VDD	214 DQ46	/RESET	Register and PLL Reset
5 GND	35 GND	65 GND	95 DQ42	125 DM0/DQS9	155 DM3/DQS12	185 CK0	215 DQ47	/S[1:0]	Chip Selects
6 /DQS0	36 /DQS3	66 GND	96 DQ43	126 /DQS9	156 /DQS12	186 /CK0	216 GND	/WE	Write Enable
7 DQS0	37 DQS3	67 VDD	97 GND	127 GND	157 GND	187 VDD	217 DQ52	A[15:0]	Address Inputs
8 GND	38 GND	68 Par_In	98 DQ48	128 DQ6	158 DQ30	188 A0	218 DQ53	BA[2:0]	Bank Addresses
9 DQ2	39 DQ26	69 VDD	99 DQ49	129 DQ7	159 DQ31	189 VDD	219 GND	CB[7:0]	Data Check Bits
10 DQ3	40 DQ27	70 A10	100 GND	130 GND	160 GND	190 BA1	220 NC	CK0, /CK0	Differential Clock Inputs
11 GND	41 GND	71 BA0	101 SA2	131 DQ12	161 CB4	191 VDD	221 NC	CKE[1:0]	Clock Enables
12 DQ8	42 CB0	72 VDD	102 NC	132 DQ13	162 CB5	192 /RAS	222 GND	DQ[63:0]	Data Bits
13 DQ9	43 CB1	73 /WE	103 GND	133 GND	163 GND	193 /S0	223 DM6/DQS15	DQS[17:0], /DQS[17:0]	Differential Data Strobes
14 GND	44 GND	74 /CAS	104 /DQS6	134 DM1/DQS10	164 DM8/DQS17	194 VDD	224 /DQS15	DM[8:0]	Data Mask
15 /DQS1	45 /DQS8	75 VDD	105 DQS6	135 /DQS10	165 /DQS17	195 ODT0	225 GND	GND	Ground
16 DQS1	46 DQS8	76 /S1*	106 GND	136 GND	166 GND	196 A13	226 DQ54	NC	No Connection
17 GND	47 GND	77 ODT1*	107 DQ50	137 NC	167 CB6	197 VDD	227 DQ55	ODT[1:0]	On Die Termination Inputs
18 /RESET	48 CB2	78 VDD	108 DQ51	138 NC	168 CB7	198 GND	228 GND	Par_In	Parity Bit, Address & Control
19 NC	49 CB3	79 GND	109 GND	139 GND	169 GND	199 DQ36	229 DQ60	SA[2:0]	SPD Address
20 GND	50 GND	80 DQ32	110 DQ56	140 DQ14	170 VDD	200 DQ37	230 DQ61	SCL	SPD Clock Input
21 DQ10	51 VDD	81 DQ33	111 DQ57	141 DQ15	171 CKE1*	201 GND	231 GND	SDA	SPD Data Input/Output
22 DQ11	52 CKE0	82 GND	112 GND	142 GND	172 VDD	202 DM4/DQS13	232 DM7/DQS16	VDD	Power
23 GND	53 VDD	83 /DQS4	113 /DQS7	143 DQ20	173 A15	203 /DQS13	233 /DQS16	VDDSPD	SPD EEPROM Power
24 DQ16	54 BA2	84 DQS4	114 DQS7	144 DQ21	174 A14	204 GND	234 GND	VREF	Reference Voltage
25 DQ17	55 /Err_Out	85 GND	115 GND	145 GND	175 VDD	205 DQ38	235 DQ62		
26 GND	56 VDD	86 DQ34	116 DQ58	146 DM2/DQS11	176 A12	206 DQ39	236 DQ63		
27 /DQS2	57 A11	87 DQ35	117 DQ59	147 /DQS11	177 A9	207 GND	237 GND		
28 DQS2	58 A7	88 GND	118 GND	148 GND	178 VDD	208 DQ44	238 VDDSPD		
29 GND	59 VDD	89 DQ40	119 SDA	149 DQ22	179 A8	209 DQ45	239 SA0		
30 DQ18	60 A5	90 DQ41	120 SCL	150 DQ23	180 A6	210 GND	240 SA1		

* = Not Used.

Front view

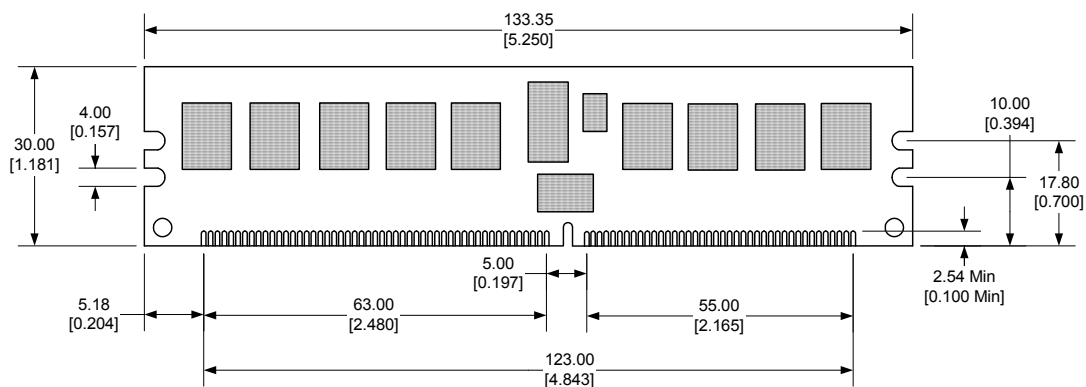

Back view

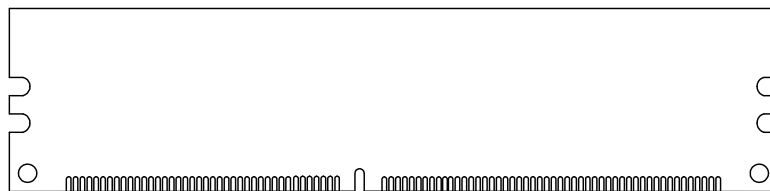

Side view

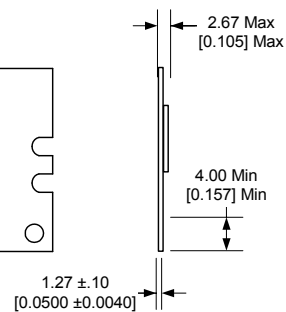

Notes

Tolerances on all dimensions except where otherwise indicated are $\pm .13$ (.005).

All dimensions are expressed: millimeters [inches]

DTM63392F

1GB - 240-Pin Registered ECC DDR2 DIMM w/CMD/ADD Parity

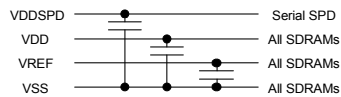
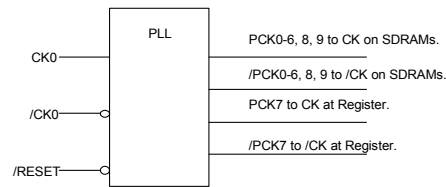
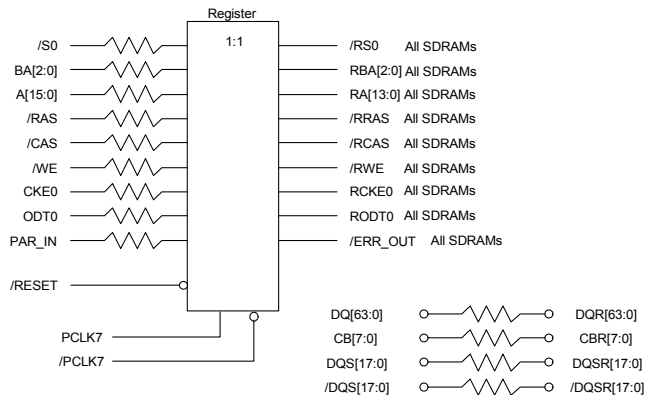
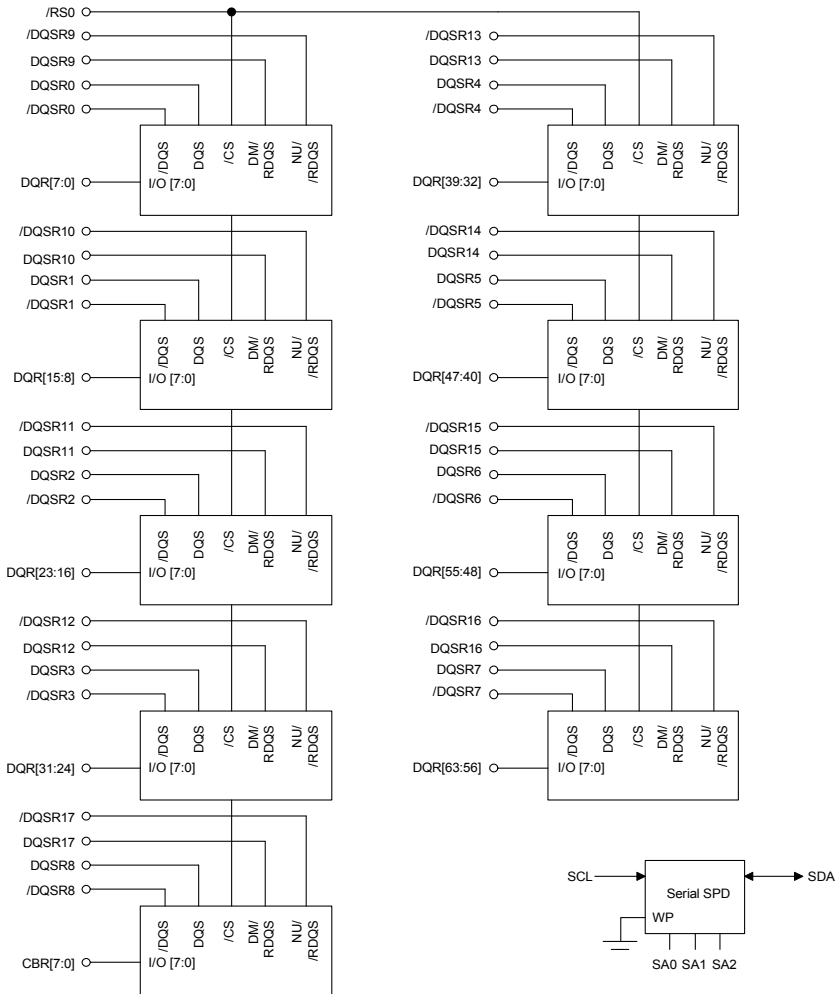

1. Unless otherwise noted, resistor values are 22 ohms +/- 5%.

Absolute Maximum Ratings

(Note: Operation at or above Absolute Maximum Ratings can adversely affect module reliability.)

PARAMETER	Symbol	Minimum	Maximum	Unit
Temperature, non-Operating	$T_{STORAGE}$	-55	100	C
DRAM Case Temperature, Operating	T_{CASE}	0	95	C
Voltage on V_{DD} relative to V_{SS}	V_{DD}	-1.0	2.3	V
Voltage on Any Pin relative to V_{SS}	V_{IN}, V_{OUT}	-0.5	2.3	V

Recommended DC Operating Conditions (Voltages referenced to $V_{SS} = 0$ V)

PARAMETER	Symbol	Minimum	Typical	Maximum	Unit	Note
Power Supply Voltage	V_{DD}	1.7	1.8	1.9	V	
I/O Reference Voltage	V_{REF}	$0.49 V_{DD}$	$0.50 V_{DD}$	$0.51 V_{DD}$	V	1
Bus Termination Voltage	V_{TT}	$V_{REF} - 0.04$	V_{REF}	$V_{REF} + 0.04$	V	

Notes:

- The value of V_{REF} is expected to equal one-half V_{DD} and to track variations in the V_{DD} DC level. Peak-to-peak noise on V_{REF} may not exceed $\pm 1\%$ of its DC value.

DC Input Logic Levels, Single-Ended (Voltages referenced to $V_{SS} = 0$ V)

PARAMETER	Symbol	Minimum	Maximum	Unit
Logical High (Logic 1)	$V_{IH(DC)}$	$V_{REF} + 0.125$	$V_{DD} + 0.300$	V
Logical Low (Logic 0)	$V_{IL(DC)}$	-0.300	$V_{REF} - 0.125$	V

AC Input Logic Levels, Single-Ended (Voltages referenced to $V_{SS} = 0$ V)

PARAMETER	Symbol	Minimum	Maximum	Unit
Logical High (Logic 1)	$V_{IH(AC)}$	$V_{REF} + 0.250$	-	V
Logical Low (Logic 0)	$V_{IL(AC)}$	-	$V_{REF} - 0.250$	V

Differential Input Logic Levels (Voltages referenced to $V_{SS} = 0\text{ V}$)

PARAMETER	Symbol	Minimum	Maximum	Unit	Note
DC Input Signal Voltage	$V_{IN(DC)}$	-0.300	$V_{DD} + 0.300$	V	1
DC Differential Input Voltage	$V_{ID(DC)}$	-0.250	$V_{DD} + 0.600$	V	2
AC Differential Input Voltage	$V_{ID(AC)}$	-0.500	$V_{DD} + 0.600$	V	3
AC Differential Cross-Point Voltage	$V_{IX(AC)}$	$0.50 V_{DD} - 0.175$	$0.50 V_{DD} + 0.175$	V	4

Notes:

1. $V_{IN(DC)}$ specifies the allowable DC excursion of each input of a differential pair.
2. $V_{ID(DC)}$ specifies the input differential voltage, *i.e.* the absolute value of the difference between the two voltages of a differential pair.
3. $V_{ID(AC)}$ specifies the input differential voltage required for switching.
4. The typical value of $V_{IX(AC)}$ is expected to be $0.5 V_{DD}$ and is expected to track variations in V_{DD} .

Capacitance ($0\text{ C} < T_{CASE} < 55\text{ C}$, $f = 100\text{ MHz}$, $V_{OUT(DC)} = V_{DD}/2$, $V_{OUT(ac)} = 0.1V(p-p)$)

PARAMETER	Pin	Symbol	Minimum	Maximum	Unit
Input Capacitance, Clock	CK0, /CK0	CIN1	1	2	pF
Input Capacitance, Address and Control	BA[2:0], A[15:0], /S0, /RAS, /CAS, /WE, CKE0, ODT0	CIN2	2.5	3.5	pF
Input/Output Capacitance	DQ[63:0], CB[7:0], DQS[17:0], /DQS[17:0]	CIO	2.5	4	pF

DC Characteristics (Voltages referenced to $V_{SS} = 0\text{ V}$)

PARAMETER	Symbol	Minimum	Maximum	Unit	Note
Input Leakage Current	I_{LI}	-5	5	μA	1
Output Leakage Current	I_{OZ}	-5	5	μA	2
Output Minimum Source DC Current	I_{OH}	-13.4	-	mA	3
Output Minimum Sink DC Current	I_{OL}	+13.4	-	mA	4

Notes:

1. These values are guaranteed by design and are tested on a sample basis only
2. DQx and ODT are disabled, and $0\text{ V} \leq V_{OUT} \leq V_{DD}$.
3. $V_{DD} = 1.7\text{ V}$, $V_{OUT} = 1420\text{ mV}$. $(V_{OUT} - V_{DD})/I_{OH}$ must be less than 21 Ohms for values of V_{OUT} between V_{DD} and $(V_{DD} - 280\text{ mV})$.
4. $V_{DD} = 1.7\text{ V}$, $V_{OUT} = 280\text{ mV}$. V_{OUT}/I_{OL} must be less than 21 Ohms for values of V_{OUT} between 0 V and 280 mV .

I_{DD} Specifications and Conditions (Voltages referenced to V_{ss} = 0 V)

PARAMETER	Symbol	Test Condition	Max Value	Unit
Operating One Bank Active-Precharge Current	I _{DD0}	CKE is HIGH, /CS is HIGH between valid commands; Address bus inputs are switching; Data bus inputs are switching.	770	mA
Operating One Bank Active-Read-Precharge Current	I _{DD1}	I _{OUT} = 0 mA; BL = 4, CL = 5 ns, AL = 0; CKE is HIGH, /CS is HIGH between valid commands; Address bus inputs are switching.	880	mA
Precharge Power-Down Current	I _{DD2P}	All banks idle; CKE is LOW; Other control and address bus inputs are stable; Data bus inputs are floating.	250	mA
Precharge Standby Current	I _{DD2N}	All banks idle; CKE is HIGH, /CS is HIGH; Other control and address bus inputs are switching; Data bus inputs are switching.	630	mA
Active Power-Down Current	I _{DD3P}	All banks open; CKE is LOW; Other control and address bus inputs are stable; Data bus inputs are floating. Fast Power-down exit (Mode Register bit 12 = 0)	330	mA
Active Standby Current	I _{DD3N}	All banks open; t _{RAS} = 70 ns; CKE is HIGH, /CS is HIGH between valid commands; Other control and address bus inputs are switching; Data bus inputs are switching.	650	mA
Operating Burst Write Current	I _{DD4W}	Burst Write: All banks open; Continuous burst writes; BL = 4; AL = 0, CL = CL(IDD); t _{CK} = t _{CK} (IDD); t _{RAS} = t _{RAS} .MAX(IDD), t _{RP} = t _{RP} (IDD); CKE is HIGH, CS is HIGH between valid commands. Address inputs are switching; Data Bus inputs are switching;	1431	mA
Operating Burst Read Current	I _{DD4R}	Burst Read: All banks open; Continuous burst reads; BL = 4; AL = 0, CL = CL(IDD); t _{CK} = t _{CK} (IDD); t _{RAS} = t _{RAS} .MAX(IDD), t _{RP} = t _{RP} (IDD); CKE is HIGH, CS is HIGH between valid commands. Address inputs are switching; Data Bus inputs are switching; I _{OUT} = 0 mA.	1324	mA
Burst Refresh Current	I _{DD5}	Refresh command at every 7.8 us; CKE is HIGH, /CS is HIGH between valid commands; Other control and address bus inputs are switching; Data bus inputs are switching.	2160	mA
Self Refresh Current	I _{DD6}	CK and /CK at 0 V; CKE ≤ 0.2 V; Other control and address bus inputs are floating; Data bus inputs are floating.	270	mA
Operating Bank Interleave Read Current	I _{DD7}	All bank interleaving reads, I _{OUT} = 0 mA; BL = 4, CL = 5 t _{CK} ; AL = 70 ns; t _{R RD} = 7.5 ns; CKE is HIGH, /CS is HIGH between valid commands; Address bus inputs are stable during deselects; Data bus inputs are switching.	2360	mA

- Notes: 1. For all I_{DDX} measurements, t_{CK} = 3 ns, t_{RC} = 60 ns, t_{RCD} = 15 ns, t_{RAS} = 45 ns, and t_{RP} = 15 ns unless otherwise specified.
 2. All I_{DDX} values shown are worst-case maximums, considering all DRAMs, Register, and the PLL.

AC Operating Conditions

PARAMETER	Symbol	Min	Max	Unit
DQ Output Access Time from Clock	t_{AC}	-450	+450	ps
CAS-to-CAS Command Delay	t_{CCD}	2	-	t_{CK}
Clock High Level Width	t_{CH}	0.45	0.55	t_{CK}
Clock Cycle Time	t_{CK}	3,000	8000	ps
Clock Low Level Width	t_{CL}	0.45	0.55	t_{CK}
Data Input Hold Time after DQS Strobe	t_{DH}	175	-	ps
DQ Input Pulse Width	t_{DIPW}	0.35	-	t_{CK}
DQS Output Access Time from Clock	t_{DQSCK}	-400	+400	ps
Write DQS High Level Width	t_{DQSH}	0.35	-	t_{CK}
Write DQS Low Level Width	t_{DQSL}	0.35	-	t_{CK}
DQS-Out Edge to Data-Out Edge Skew	t_{DQSQ}	240	-	ps
Data Input Setup Time Before DQS Strobe	t_{DS}	100	-	ps
DQS Falling Edge from Clock, Hold Time	t_{DSH}	0.2	-	t_{CK}
DQS Falling Edge to Clock, Setup Time	t_{DSS}	0.2	-	t_{CK}
Clock Half Period	t_{HP}	minimum of t_{CH} or t_{CL}	-	ns
Address and Command Hold Time after Clock	t_{IH}	275	-	ps
Address and Command Setup Time before Clock	t_{IS}	200	-	ps
Load Mode Command Cycle Time	t_{MRD}	2	-	t_{CK}
DQ-to-DQS Hold	t_{QH}	$t_{HP} - t_{QHS}$	-	-
Data Hold Skew Factor	t_{QHS}	340	-	ps
Active-to-Precharge Time	t_{RAS}	45	70K	ns
Active-to-Active / Auto Refresh Time	t_{RC}	60	-	ns
RAS-to-CAS Delay	t_{RCD}	15	-	ns
Average Periodic Refresh Interval	t_{REFI}	-	7.8	μ s
Auto Refresh Row Cycle Time	t_{RFC}	127.5	-	ns
Row Precharge Time	t_{RP}	15	-	ns
Read DQS Preamble Time	t_{RPRE}	0.9	1.1	t_{CK}
Read DQS Postamble Time	t_{RPST}	0.4	0.6	t_{CK}
Row Active to Row Active Delay	t_{RRD}	7.5	-	ns
Internal Read to Precharge Command Delay	t_{RTP}	7.5	-	ns
Write DQS Preamble Time	t_{WPRE}	0.35	-	ps
Write DQS Postamble Time	t_{WPST}	0.4	0.6	t_{CK}
Write Recovery Time	t_{WR}	15	-	ns
Internal Write to Read Command Delay	t_{WTR}	7.5	-	ns
Exit Self Refresh to Non-Read Command	t_{XSNR}	$t_{RFC}(\text{min}) + 10$	-	ns
Exit Self Refresh to Read Command	t_{XSRD}	200	-	t_{CK}

SERIAL PRESENCE DETECT MATRIX

Byte#	Function.	Value	Hex
0	Number of Bytes Utilized by Module Manufacturer	128 bytes	0x80
1	Total number of Bytes in Serial PD device	256 bytes	0x08
2	Memory Type	DDR2 SDRAM	0x08
3	Number of Row Addresses	14	0x0E
4	Number of Column Addresses	10	0x0A
5	Module Attributes - Number of Ranks, Package and Height		0x60
	# of Ranks -	1	
	Card on Card -	No	
	DRAM Package -	Planar	
	Module Height -	30mm	
6	Module Data Width.	72	0x48
7	Reserved	UNUSED	0x00
8	Voltage Interface Level of this assembly	SSTL/1.8V	0x05
9	SDRAM Cycle time. (Max. Supported CAS Latency). CL=X (tCK) ns	3	0x30
10	SDRAM Access from Clock. (Highest CAS latency). (tAC) ns	0.45	0x45
11	DIMM configuration type (Non-parity, Parity or ECC)		0x06
	Data Parity -		
	Data ECC -	X	
	Address/Command Parity -	X	
	TBD -		
	TBD -		
	TBD -		
	TBD -		
	TBD -		
12	Refresh Rate/Type (us)	7.8 (SR)	0x82
13	Primary SDRAM Width	8	0x08
14	Error Checking SDRAM Width	8	0x08
15	Reserved	UNUSED	0x00
16	SDRAM Device Attributes: Burst Lengths Supported		0x0C
	TBD -		
	TBD -		
	Burst Length = 4 -	X	
	Burst Length = 8 -	X	
	TBD -		
	TBD -		
	TBD -		
	TBD -		
17	SDRAM Device Attributes - Number of Banks on SDRAM Device	8	0x08
18	SDRAM Device Attributes: CAS Latency		0x30
	TBD -		
	TBD -		
	Latency = 2 -		

	Latency = 3 -		
	Latency = 4 -	X	
	Latency = 5 -	X	
	Latency = 6 -		
	TBD -		
19	DIMM Mechanical Characteristics. Max. module thickness. (mm)	x <= 4.10	0x01
20	DIMM type information		0x01
	Regular RDIMM (133.35mm) -	X	
	Regular UDIMM (133.35mm) -		
	SODIMM (67.6mm) -		
	Micro-DIMM (45.5mm) -		
	Mini RDIMM (82.0mm) -		
	Mini UDIMM (82.0mm) -		
	TBD -		
	TBD -		
21	SDRAM Module Attributes (Refer to Byte20 for DIMM type information).		0x04
	Number of active registers on the DIMM (N/A for UDIMM) -	1	
	Number of PLL on the DIMM (N/A for UDIMM) -	1	
	FET Switch External Enable -	No	
	TBD -		
	Analysis probe installed -	No	
	TBD -		
22	SDRAM Device Attributes: General		0x03
	Includes Weak Driver -	X	
	Supports 50 ohm ODT -	X	
	Supports PASR (Partial Array Self Refresh) -		
	TBD -		
	TBD -		
	TBD -		
	TBD -		
	TBD -		
23	Minimum Clock Cycle Time at Reduced CAS Latency, CL = X-1 (ns)	3.75	0x3D
24	Maximum Data Access Time (tAC) from Clock at CL = X- 1 (ns)	0.45	0x45
25	Minimum Clock Cycle Time at CL = X-2 (ns)	UNUSED	0x00
26	Maximum Data Access Time (tAC) from Clock at CL = X-2 (ns)	UNUSED	0x00
27	Minimum Row Precharge Time (tRP) (ns)	15	0x3C
28	Minimum Row Active to Row Active Delay (tRRD) (ns)	7.5	0x1E
29	Minimum RAS to CAS Delay (tRCD) (ns)	15	0x3C
30	Minimum Active to Precharge Time (tRAS) (ns)	45	0x2D
31	Module Rank Density	1GB	0x01
32	Address and Command Setup Time Before Clock (tIS) (ns)	0.2	0x20
33	Address and Command Hold Time After Clock (tIH) (ns)	0.27	0x27
34	Data Input Setup Time Before Strobe (tDS) (ns)	0.1	0x10
35	Data Input Hold Time After Strobe (tDH) (ns)	0.17	0x17
36	Write Recovery Time (tWR) (ns)	15	0x3C

37	Internal write to read command delay (tWTR) (ns)	7.5	0x1E
38	Internal read to precharge command delay (tRTP) (ns)	7.5	0x1E
39	Memory Analysis Probe Characteristics.	UNUSED	0x00
40	Extension of Byte 41(tRC) and Byte 42 (tRFC) (ns)		0x06
	Add this value to byte 41 -	0	
	Add this value to byte 42 -	0.5	
41	SDRAM Device Minimum Active to Active/Auto Refresh Time (tRC) (ns)	60	0x3C
42	SDRAM Device Minimum Auto-Refresh to Active/Auto-Refresh Command Period (tRFC). (ns)	127.5	0x7F
43	SDRAM Device Maximum Cycle Time (tCK max). (ns)	8	0x80
44	SDRAM Dev DQS-DQ Skew for DQS & DQ signals (tDQSQ) (ns)	0.24	0x18
45	DDR SDRAM Device Read Data Hold Skew Factor (tQHS) (ns)	0.34	0x22
46	PLL Relock Time (us)	6	0x06
47	DRAM maximum Case Temperature Delta. (Degree C).		0x51
	DT4R4W Delta (Bits 0:3) -	0.4	
	Tcasemax delta (Bits 7:4) -	10	
48	Thermal Resistance of DRAM Package from Top (Case) to Ambient (Psi T-A DRAM). (C/Watt)	58	0x74
49	DRAM Case Temperature Rise from Ambient due to Activate-Precharge/ Mode Bits (DT0/Mode Bits). (Degree C).		0x57
	Bit 0. If "0" DRAM does not support high temperature self-refresh entry -	1	
	Bit 1. If "0" Do not need double refresh rate for the proper operation -	1	
	DT0, (Bits 2:7) -	6.3	
50	DRAM Case Temperature Rise from Ambient due to Precharge/Quiet Standby (DT2N/DT2Q). (Degree C).	6	0x3C
51	DRAM Case Temperature Rise from Ambient due to Precharge Power-Down (DT2P). (Degree C).	1.44	0x60
52	DRAM Case Temperature Rise from Ambient due to Active Standby (DT3N). (Degree C).	6.9	0x2E
53	DRAM Case temperature Rise from Ambient due to Active Power-Down with Fast PDN Exit (DT3Pfast). (Degree C).	4.4	0x58
54	DRAM Case temperature Rise from Ambient due to Active Power-Down with Slow PDN Exit (DT3Pslow). (Degree C).	2.2	0x58
55	DRAM Case Temperature Rise from Ambient due to Page Open Burst Read/DT4R4W Mode Bit (DT4R/DT4R4W Mode Bit). (Degree C).		0x4A
	Bit 0. "0" if DT4W is greater than DT4R -	0	
	DT4R, (Bits 1:7) -	14.8	
56	DRAM Case Temperature Rise from Ambient due to Burst Refresh (DT5B). (Degree C).	24.5	0x31

57	DRAM Case Temperature Rise from Ambient due to Bank Interleave Reads with Auto-Precharge (DT7). (Degree C).	26.5	0x35
58	Thermal Resistance of PLL Package from Top to Ambient (Psi T-A PLL). (C/Watt).	87	0xAE
59	Thermal Resistance of Register Package from Top to Ambient (Psi T-A Register). (C/Watt).	70	0x8C
60	PLL Case Temperature Rise from Ambient due to PLL Active (DT PLL Active). (Degree C).	33.5	0x86
61	Register Case Temperature Rise from Ambient due to Register Active/Mode Bit (DT Register Active/Mode Bit).		0x7C
	Bit 0.If "0"Unit for Bits 2:7 is 0.75C -	0.75	
	Bit 1. RFU. Default: 0 -	0	
	Register Active,(Bits 2:7) -	23.25	
62	SPD Revision	Revision 1.2	0x12
63	Checksum for Bytes 0-62		0xF0
64	Module Manufacturer's JEDEC ID Code	Dataram ID	0x7F
65	Module Manufacturer's JEDEC ID Code	Dataram ID	0x91
66-71	Module Manufacturer's JEDEC ID Code	UNUSED	0x00
72	Module Manufacturing Location	UNUSED	0x00
73-90	Module Part Number		0x20
91,92	Module Revision Code	UNUSED	0x00
93,94	Module Manufacturing Date	UNUSED	0x00
95-98	Module Serial Number	#	0x23
99-127	Manufacturer's Specific Data	UNUSED	0x00



DTM63392F

1GB - 240-Pin Registered ECC DDR2 DIMM w/CMD/ADD Parity



DATARAM CORPORATION, USA Corporate Headquarters, P.O.Box 7528, Princeton, NJ 08543-7528;
Voice: 609-799-0071, Fax: 609-799-6734; www.dataram.com

All rights reserved.

The information contained in this document has been carefully checked and is believed to be reliable. However, Dataram assumes no responsibility for inaccuracies.

The information contained in this document does not convey any license under the copyrights, patent rights or trademarks claimed and owned by Dataram.

No part of this publication may be copied or reproduced in any form or by any means, or transferred to any third party without prior written consent of Dataram.