

ADD7308-S

PCI Express Digital Display Card

Specifications

Features

- Single/Dual LVDS transmitter up to 165Mpixels/s
- LVDS low jitter PLL accepts spread spectrum input
- LVDS 18-bit and 24-bit outputs
- 2D dither engine
- Panel protection and power sequencing
- High-speed SDVOI serial (1G~2Gbps) AC-coupled differential RGB inputs
- Low voltage interface supports graphics device
- Programmable power management
- Fully programmable through serial port
- Configuration through OpCodes
- Supports complete Windows driver
- Supports boundary scan

Chip

- Chronitel CH7308B

Temperature

- 0°C to 60°C

Humidity

- 10% to 90%

Dimensions

- 14.5cm x 6cm (5.7"x2.36")

Board Layout

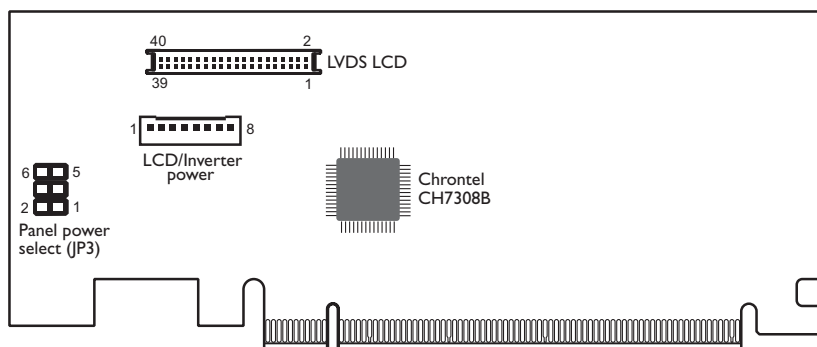

Panel Power Select	JP3
12V	1-2 On
5V	3-4 On
3.3V (default)	5-6 On

Before powering-on the system, make sure settings on JP3 match the LCD panel's specifications. Selecting the incorrect voltage will seriously damage the LCD panel.

LVDS LCD Panel Connector

Pins	Function	Pins	Function
1	GND	2	GND
3	LVDS_Out3+	4	LVDS_Out7+
5	LVDS_Out3-	6	LVDS_Out7-
7	GND	8	GND
9	LVDS_Out2+	10	LVDS_Out6+
11	LVDS_Out2-	12	LVDS_Out6-
13	GND	14	GND
15	LVDS_Out1+	16	LVDS_Out5+
17	LVDS_Out1-	18	LVDS_Out5-
19	GND	20	GND
21	LVDS_Out0+	22	LVDS_Out4+
23	LVDS_Out0-	24	LVDS_Out4-
25	GND	26	GND
27	LVDS_CLK1+	28	LVDS_CLK2+
29	LVDS_CLK1-	30	LVDS_CLK2-
31	GND	32	GND
33	DDC_CLK	34	N.C.
35	DDC_DATA	36	N.C.
37	Panel Power	38	Panel Power
39	Panel Power	40	Panel Power

LCD/Inverter Power Connector

Pins	Function	Pins	Function
1	GND	5	+3.3V
2	GND	6	Panel Backlight On/Off Control
3	Panel Inverter Brightness Voltage Control	7	+12V
4	Panel Power	8	+12V