

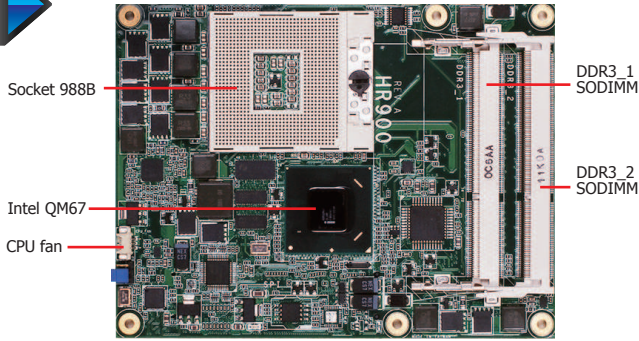

3rd/2nd Gen Intel® Core™ COM Express® Basic

HR900-B

QM67



Features

MEMORY	2 DDR3 SODIMM up to 16GB
EXPANSION	5 PCIe x1, 1 PCIe x16, 4 PCI 1 LPC, 1 SMBus, 1 IDE 1 VGA, 1 LVDS, 2 DDI (HDMI/DP/SDVO) Multiplex digital display with PCIe x16 8 USB 2.0 4 SATA: 2 SATA 3.0, 2 SATA 2.0 8-bit DIO
LAN	1 LAN
DIMENSIONS	COM Express® R1.0 Basic, Type 2 95mm x 125mm (3.74" x 4.9")

Mechanical Drawing

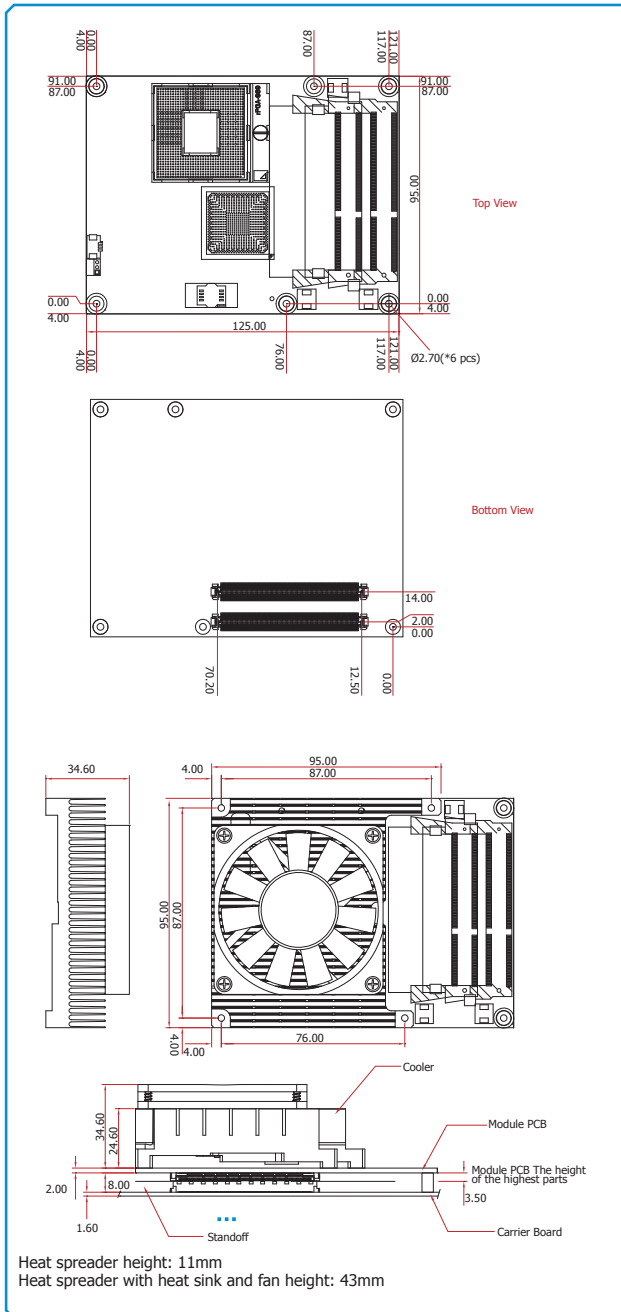

Block Diagram

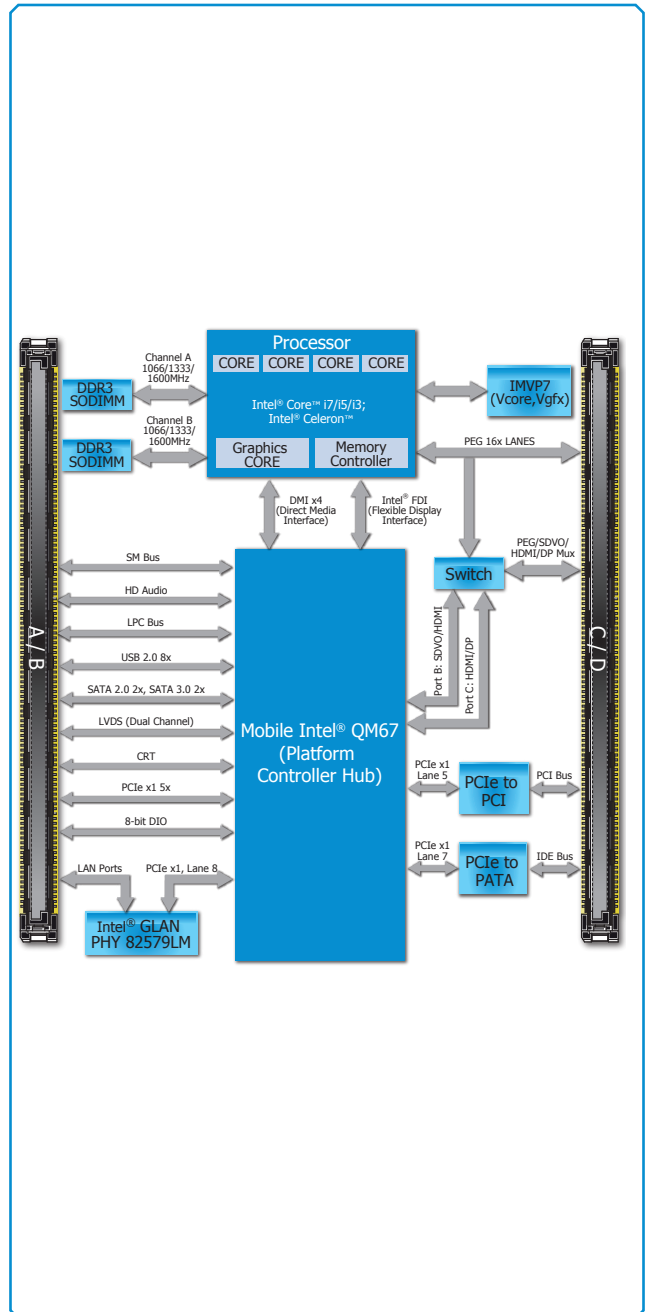

HR900-B

Specifications

PROCESSOR

- Socket G2 988B for:
 - 3rd Generation Intel® Core™ processors (22nm process technology)
 - : Intel® Core™ i7-3610QE (6M Cache, up to 3.3 GHz); 45W
 - : Intel® Core™ i5-3610ME (3M Cache, up to 3.3 GHz); 35W
 - : Intel® Core™ i3-3120ME (3M Cache, 2.4 GHz); 35W
 - 2nd Generation Intel® Core™ processors (32nm process technology)
 - : Intel® Core™ i7-2710QE (6M Cache, up to 3.0 GHz); 45W
 - : Intel® Core™ i5-2510E (3M Cache, up to 3.1 GHz); 35W
 - : Intel® Core™ i3-2330E (3M Cache, 2.2 GHz); 35W
 - : Intel® Celeron® B810 (2M Cache, 1.6 GHz); 35W
- Intel® Advanced Vector Extensions (Intel® AVX) Instructions
- Intel® Turbo Boost Technology

CHIPSET

- Intel® QM67 Express Chipset

SYSTEM MEMORY

- Two 204-pin DDR3 SODIMM sockets

3rd Generation Processors	2nd Generation Processors
DDR3 1066/1333/1600MHz	DDR3 1066/1333MHz (i5/i3/Celeron)
	DDR3 1600MHz (i7)

- Supports dual channel memory interface
- Supports up to 16GB system memory
- DRAM device technologies: 1Gb, 2Gb and 4Gb DDR3 DRAM technologies are supported for x8 and x16 devices, unbuffered, non-ECC

ONBOARD GRAPHICS FEATURES

- Intel® HD Graphics 4000 (3rd generation processors)
- Intel® HD Graphics 3000 (2nd generation processors)
- Intel® HD Graphics (Intel® Celeron® processors)
- Supports VGA, LVDS and DDI interfaces
- VGA: resolution up to 2048x1536 @ 75Hz
- LVDS: Single Channel - 18/24-bit; Dual Channel - 36/48-bit, resolution up to 1920x1200 @ 60Hz
- Digital Display Interfaces: HDMI, DP and SDVO (for Port B)
- HDMI, DP: resolution up to 1920x1200 @ 60Hz
- Supports 6 or 16 Graphics Execution Units (EUs) (3rd generation processors)
- Supports 6 or 12 Graphics Execution Units (EUs) (2nd generation processors)
- Intel® Clear Video Technology
- DirectX Video Acceleration (DXVA) support for accelerating video processing
- Supports DirectX 11/10.1/10/9 and OpenGL 3.0 (3rd generation processors)
- Supports DirectX 10.1/10/9 and OpenGL 3.0 (2nd generation processors)

ONBOARD AUDIO FEATURES

- Supports High Definition Audio interface

ONBOARD LAN FEATURES

- Intel® 82579LM Gigabit Ethernet PHY
- Integrated 10/100/1000 transceiver
- Fully compliant with IEEE 802.3, IEEE 802.3u, IEEE 802.3ab

SERIAL ATA (SATA) INTERFACE

- Supports 4 Serial ATA interfaces
- 2 SATA 2.0 with data transfer rate up to 3Gb/s
- 2 SATA 3.0 with data transfer rate up to 6Gb/s
- Integrated Advanced Host Controller Interface (AHCI) controller

IDE INTERFACE

- Supports up to two IDE devices
- DMA mode: Ultra ATA up to 100MB/s
- PIO mode: up to 16MB/s

EXPANSION INTERFACES

- Supports 8 USB ports (USB 1.1/2.0 host controllers)
- Supports 4 PCI slots (PCI 2.3 interface)
- Supports PCIe x16 / SDVO / HDMI / Display Port switchable interface
 - Uses QM67's DDI (Digital Display Interface) Port B for SDVO/ HDMI and DDI Port C for Display Port / HDMI
 - VBIOS default setting at Port C only; VBIOS settings modified upon request
- Supports 1 PCIe x16 interface
 - Supports Gen 3.0 (3rd generation processors)
 - Supports Gen 2.0 (2nd generation processors)
- Supports 5 PCIe x1 interfaces
- Supports LPC interface
- Supports SMBus interface
- Supports IDE interface
- Supports 8-bit Digital I/O

DAMAGE FREE INTELLIGENCE

- Monitors CPU temperature and overheat alarm
- Monitors CPU fan speed and failure alarm
- Monitors Vcore/V_{gfx}/1.5V voltages and failure alarm
- Watchdog timer function

BIOS

- 64Mbit UEFI SPI BIOS

POWER CONSUMPTION

- 54.70 W with i7-2710QE at 2.10GHz and 2x 4GB DDR3 SODIMM

OS SUPPORT

- Windows XP Professional x86 & SP3 (32-bit)
- Windows XP Professional x64 & SP2 (64-bit)
- Windows 7 Ultimate x86 & SP1 (32-bit)
- Windows 7 Ultimate x64 & SP1 (64-bit)
- Windows 8 Enterprise x86 (32-bit)
- Windows 8 Enterprise x64 (64-bit)

TEMPERATURE

- 0°C to 60°C

HUMIDITY

- 10% to 90%

POWER

- Input: 12V, 5VSB (optional), VCC_RTC

PCB

- Dimensions
 - COM Express® Basic
 - 95mm (3.74") x 125mm (4.9")
- Compliance
 - PICMG COM Express® R1.0, Type 2

CERTIFICATION

- CE, FCC Class B, UL, RoHS

Ordering Information

Model Name	Part Number	Description
HR900-B	777-HR9002-000G	3rd/2nd generation Intel® Core™ processors

Packing List

- 1 HR900-B board
- 1 QR (Quick Reference)
- 1 Drivers/utilities disk

Optional Items

- COM630-B carrier board kit
- Heat spreader: TBD
- Heat sink with fan: A71-111009-001G
- Heat spreader with heat sink and fan: TBD