

HS1C Series Full Size Solenoid Locking Switches

HS1C features:

- Rugged Aluminum Die-cast Housing
- With the actuator mounted on a movable door, and the switch on a machine, the door can be mechanically locked when closed.
- Greater Safety: The door is unlocked by a solenoid lock-release signal from a PLC or another source after the machine has stopped.
- In the event of power failure or for machine maintenance, the door can be unlocked using a special tool.
- Flexible Installation: The actuator can be accessed from two directions.
- Select from four different circuit configurations.
- IP67 Protection



GS-ET-15
BG standard in Germany



Certificate No.
20005010305145652



Direct Opening Action

HS1C Series Functionality

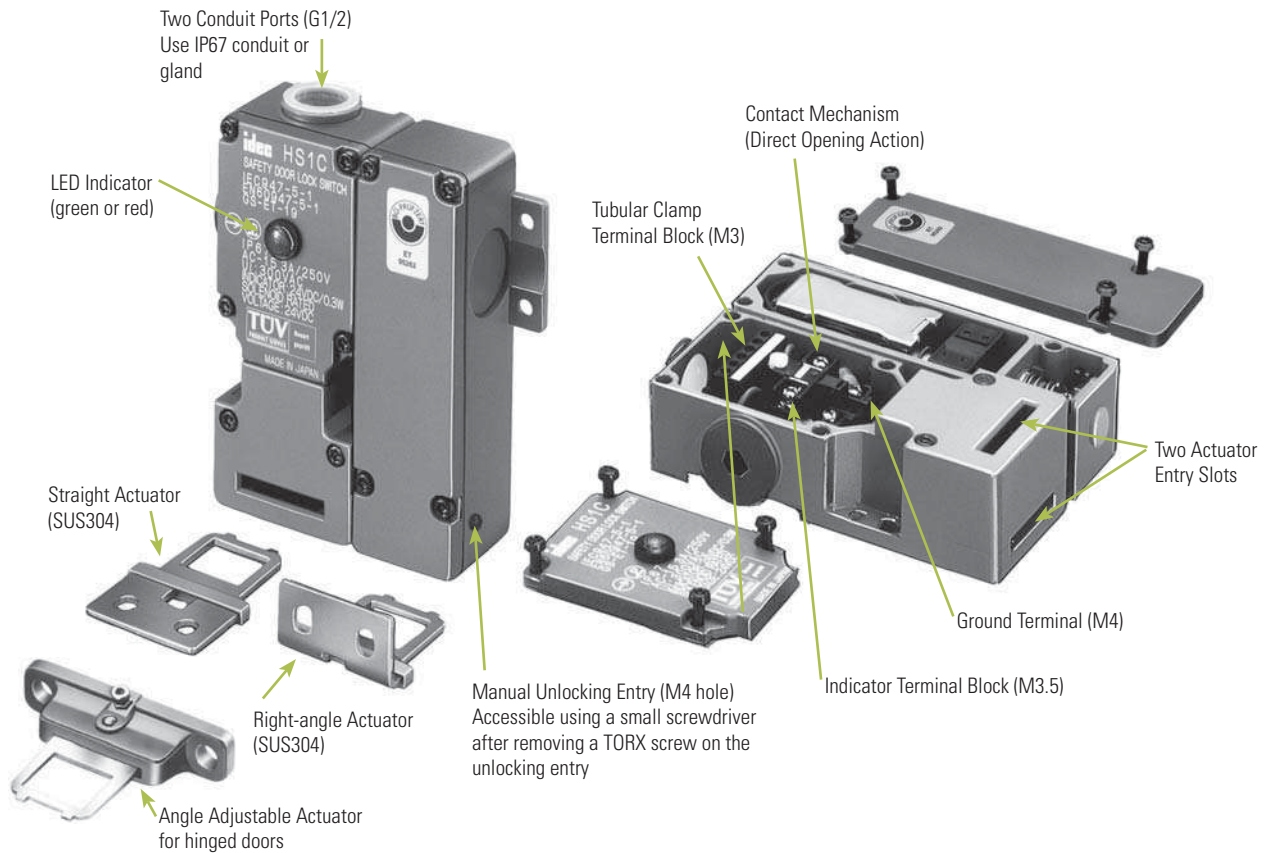

TORX is a registered trademark of Camcar Textron.

Part Numbers

Contact Configuration	Indicator LED	Part Number
Main Circuit: 1NC+1NC Auxiliary Circuit: 1NO/1NO 	Green	HS1C-R44R-G
	Red	HS1C-R44R-R
Main Circuit: 1NC+1NC Auxiliary Circuit: 1NO 	Green	HS1C-R144R-G
	Red	HS1C-R144R-R
Main Circuit: 1NC+1NC Auxiliary Circuit: 1NC+1NC 	Green	HS1C-R244R-G
	Red	HS1C-R244R-R
Main Circuit: 1NC+1NC Auxiliary Circuit: 1NC 	Green	HS1C-R344R-G
	Red	HS1C-R344R-R

Actuator Keys & Accessories

Item	Part Number	Description
	HS9Z-A1	Straight Actuator (Mainly for sliding doors)
	HS9Z-A2	Right-angle Actuator (Mainly for rotating doors)
	HS9Z-A3	Adjustable Actuator
	HS9Z-T1	Key Wrench (included with switch)

Overview

X Series E-Stops

Door Interlock Switches

Enabling Switches

Barriers

AS-Interface Safety at Work

Specifications

Conforming to Standards		EN1088, IEC60947-5-1, EN60947-5-1, GS-ET-19, UL508					
Operating Temperature		-20 to +40°C (no freezing)					
Storage Temperature		-40 to +80°C					
Operating Humidity		85% RH maximum (no condensation)					
Altitude		2,000m maximum					
Rated Insulation Voltage (Ui)		300V (between LED or solenoid and ground: 60V)					
Impulse Withstand Voltage (Uimp)		4 kV (between LED or solenoid and ground: 2.5 kV)					
Insulation Resistance		Between live and dead metal parts: 100 MΩ minimum Between live metal part and ground: 100 MΩ minimum Between live metal parts: 100 MΩ minimum Between terminals of the same pole: 100 MΩ minimum					
Electric Shock Protection Class		Class 1 (IEC61140)					
Pollution Degree		3 (IEC60947-5-1)					
Degree of Protection		IP67 (IEC60529)					
Vibration Resistance	Operating Extremes	10 to 55 Hz, amplitude 0.5 mm					
	Damage Limits	60 m/sec ² (approx. 6G)					
Shock Resistance		1,000 m/s ² (approx. 100G)					
Actuator Tensile Strength when Locked		1,500N minimum					
Operating Speed		1 m/sec maximum					
Positive Opening Travel		11 mm minimum					
Positive Opening Force		20N minimum					
Thermal Current (Ith)		Main circuit: 10A, Auxiliary circuit: 3A					
Rated Operating Current (Ie)		Operating Voltage (Ue)		30V	125V	250V	
		Main Circuit	AC	Resistive load (AC12)	10A	10A	6A
				Inductive load (AC15)	10A	5A	3A
		DC	Resistive load (DC12)	6A	-	-	
			Inductive load (DC13)	3A	0.9A	-	
		Auxiliary Circuit	AC	Resistive load (AC12)	-	3A	3A
Inductive load (AC15)	-			-	3A		
DC	Resistive load (DC12)	3A	-	-			
	Inductive load (DC13)	-	0.9A	-			
Contact Opening Distance		Main circuit: 1.7 mm max., Auxiliary circuit: 1.2 mm min.					
Operating Frequency		900 operations/hour max.					
Mechanical Life		1,000,000 operations					
Electrical Life		100,000 operations (rated load)					
Conditional Short-circuit Current		100A (IEC60947-5-1)					
Recommended Short Circuit Protection		250V, 10A fuse (Type D01 based on IEC60269-1, 60269-2)					
Solenoid Unit	Operating Voltage	24V DC					
	Current	415 mA					
	Coil Resistance	58Ω (at 20°C)					
	Energizing Voltage	Rated voltage x 85% maximum (at 20°C)					
	De-energizing Voltage	Rated voltage x 10% minimum (at 20°C)					
	Continuous Applicable Voltage	Rated voltage x 110%					
	Continuous Applicable Duration	Not specifically limited					
Indicator	Insulation Class	Class B					
	Operating Voltage	24V DC					
	Current	10 mA					
	Light Source	LED lamp					
	Lens Color	Red or Green (12 mm dia. Lens)					
Weight	Approx. 660g						

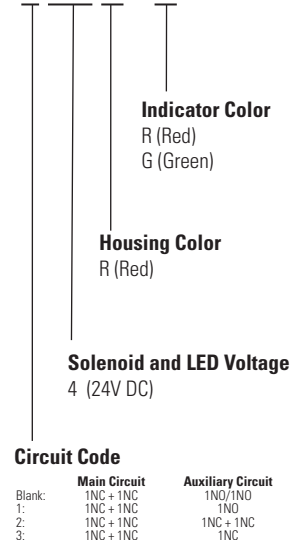
Part Number Key
HS1C - R 1 4 4 R - R

Dimensions (mm)

HS1C-R44R-* - using the straight actuator (HS9Z-A1)

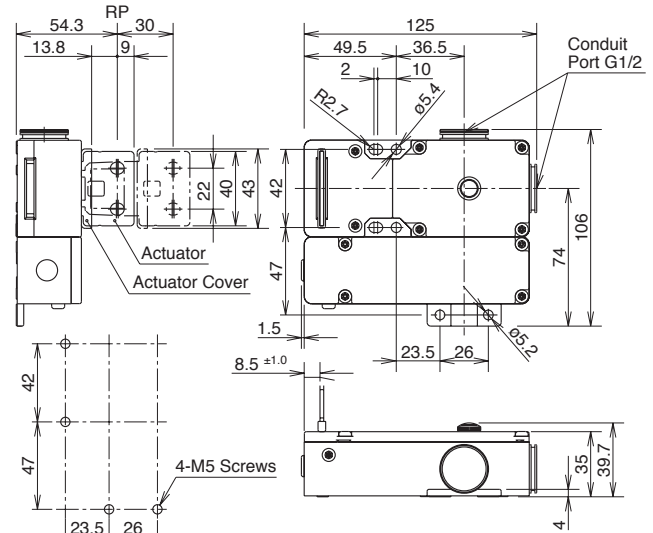
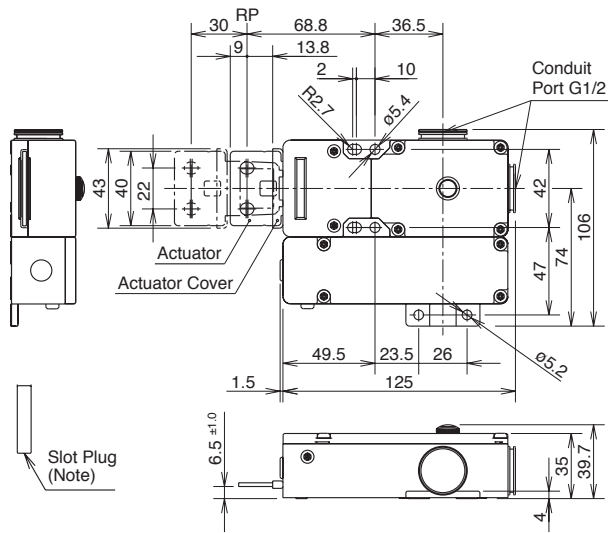

Mounting Hole Layout

HS1C-R44R-* - using the Right-angle actuator (HS9Z-A2)

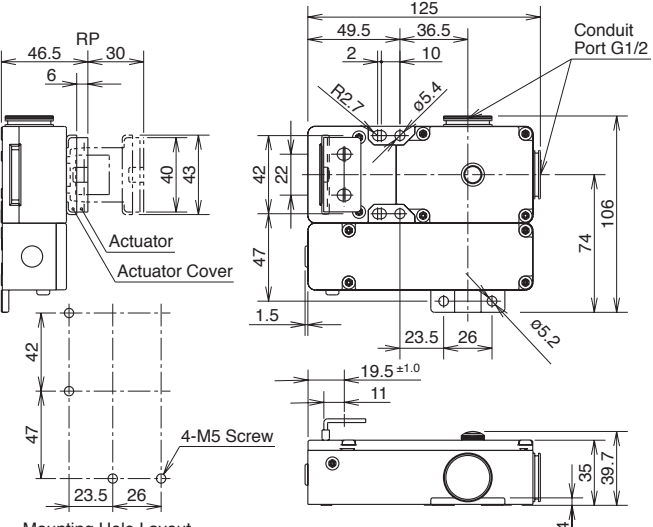
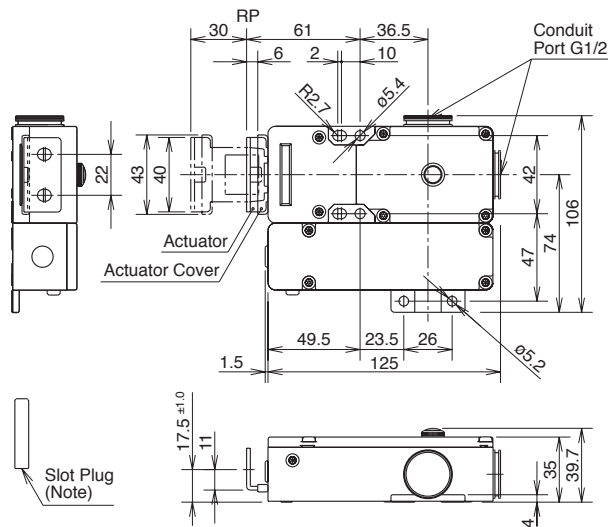

Mounting Hole Layout

Accessories

**Straight Actuator (mainly for sliding doors)
HS9Z-A1**

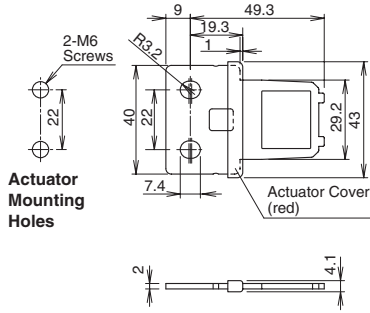

**Right-angle Actuator (mainly for hinged doors)
HS9Z-A2**

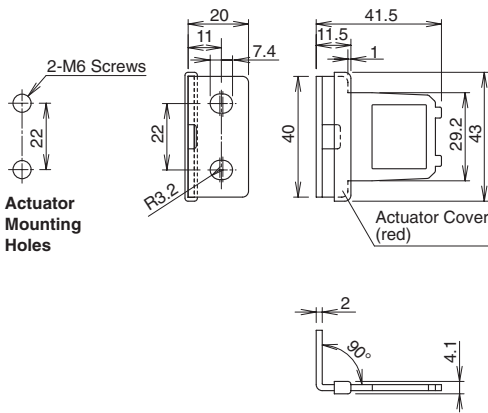

! *After installing the actuator, remove the actuator cover.

Adjustable Actuator

- The actuator angle is adjustable (0° to 20°) for hinged doors.
- The minimum radius of the door opening can be as small as 100mm.

For HS1/HS2 Series (HS9Z-A3)

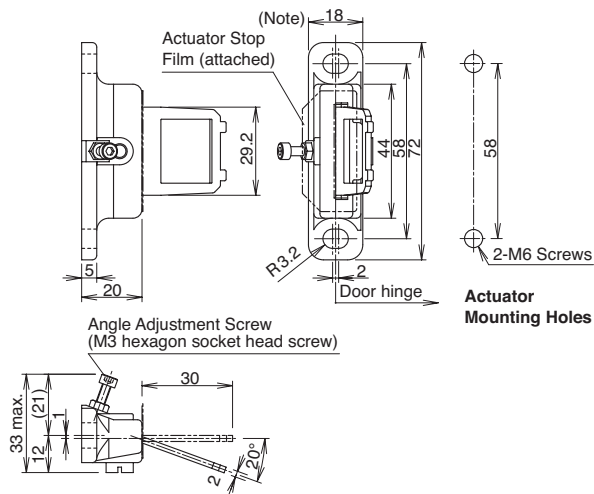

All dimensions in mm.

Overview

X Series E-Stops

Door Interlock Switches

Enabling Switches

Barriers

AS-Interface Safety at Work

Safety Precautions

- In order to avoid electric shock or a fire, turn the power off before installation, removal, wire connection, maintenance, or inspection of the switch.
- If relays are used in the circuit between the safety switch and the load, consider degrees of the danger and use safety relays, since welded or sticking contacts of standard relays may invalidate the functions of the safety switch.
- Do not place a PLC in the circuit between the safety switch and the load. The safety security can be endangered in the event of a malfunction of the PLC.
- Do not disassemble or modify the switch. It may cause a breakdown or an accident.

Operation Precautions - for all series

- Regardless of door types, do not use the safety switch as a door stop. Install a mechanical door stop at the end of the door to protect the safety switch against excessive force.
- Do not apply excessive shock to the switch when opening or closing the door.
- A shock to the door exceeding 1,000 m/sec² (approx. 100G) may cause the contacts of the switch to chatter, and a malfunction of the switch may occur.
- For connection of wires, unscrew the cover. Unnecessary loosening of other screws may cause a malfunction of the switch.
- Prevent foreign objects such as dust and liquids from entering the switch while connecting conduit or wiring.
- If the operating atmosphere is contaminated, use a protective cover to prevent the entry of foreign objects into the switch through the actuator entry slots.
- Entry of a considerable amount of foreign objects into the switch may affect the mechanism of the switch and cause a breakdown.
- Do not store the switches in a dusty, humid, or organic-gas atmosphere.

HS5E/HS5B Precautions

For Rotating Head Directions

- The heads of the HS5E/HS5B can be rotated in 90° increments after removing the 4 screws on the corners of the head. Prevent entry of foreign objects into the switch during removal of the head. Tighten these screws with torque designated in the instruction sheet. Improper torque may cause errors.

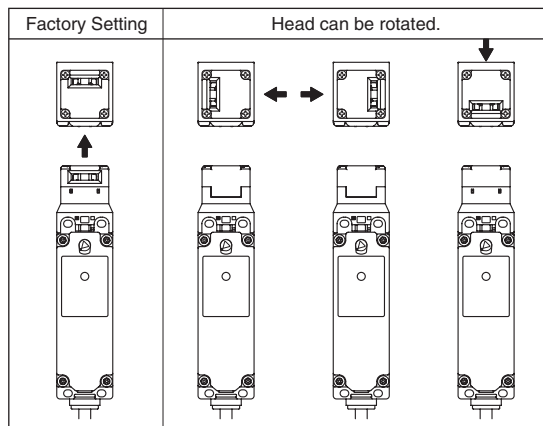

Minimum Radius of Hinged Doors

- When using the interlock switch on hinged doors, refer to the minimum radius of doors shown below. When using on doors with small minimum radius, use the angle adjustable actuator (HS9Z-A55).

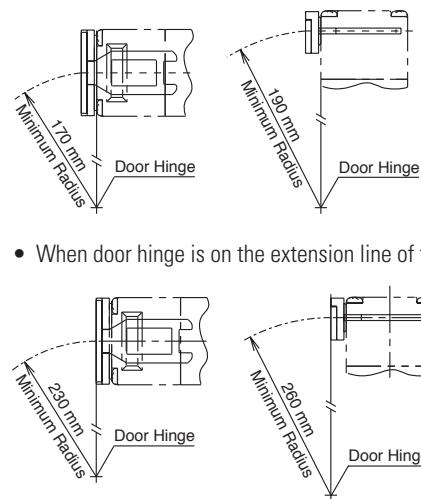

- When door hinge is on the extension line of the actuator mounting surface:

HS2B Precautions

Wire Connection

- The HS2B has 3 conduit ports, which are closed as a part of the molded switch housing.
- Make an opening for wire connection by breaking one of the conduit-port knockouts on the switch housing using a screwdriver.
- When breaking the conduit port, take care not to damage the contact block or other parts inside the switch.

- Cracks or burrs on the conduit entry may deteriorate the housing protection against water.
- When changing to another conduit port, close the unused opening with an optional plug (Part No. HS9Z-P1).

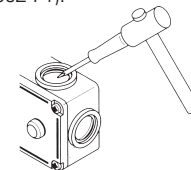

HS1E Precautions

Wire Connection

- Make an opening for wire connection by breaking one of the conduit-port knockouts on the switch housing using a screwdriver.
- Before breaking the knockout, temporarily remove the connector-fixing lock nut from the switch.
- When breaking the knockout, take care not to damage the contact block or other parts inside the switch.
- Cracks or burrs on the conduit entry may deteriorate the housing protection.
- When changing to the other conduit port, close the unused opening with an optional plug (accessory).

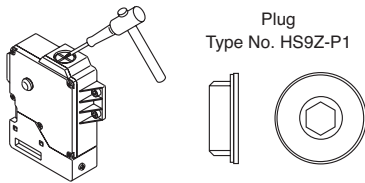

1. This unlocking method is intended for an escape from a machine when a person is locked in. For access to the unlocking entry, an access hole should be opened on the mounting panel. When opening the hole, apply proper protection against water or other foreign objects.
2. Caution: After the unlocking operation, put the screw back into the unlocking entry for safety.

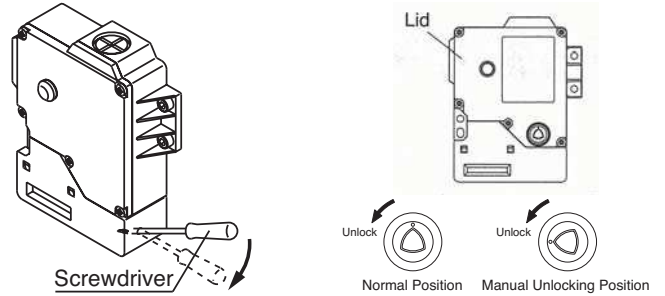

Manual Unlocking

- Remove the screw located on the unlocking entry at the side of the switch using the key wrench included with the switch. Then insert a small screwdriver into the switch to push the lever inside of the switch toward the indicator until the actuator is unlocked (refer to the diagram on the right).
- Insert a small screwdriver into the elliptical hole on the back of the switch, then push the lever inside of the switch toward the indicator until the actuator is unlocked (refer to the diagram on the right).

HS1C Precautions

- Regardless of door type, do not use the safety switch as a locking device. Install a locking device independently, for example, using a metal latch (also applicable to HS1E).
- The safety switch cover can be only removed with the special key wrench supplied with the switch or with the optional screwdriver (also applicable to HS1B and HS1E).
- Remove the screw located on the unlocking entry at the side of the switch using the key wrench included with the switch. Then insert a small screwdriver into the switch to push the lever inside of the switch toward the indicator until the actuator is unlocked (refer to the diagram on the right).

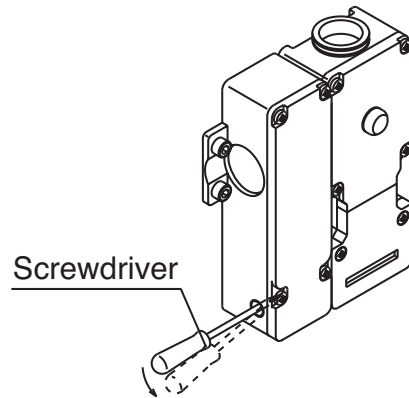

Caution: After the unlocking operation, put the screw back into the unlocking entry for safety.

Operation Precautions

Applicable Crimping Terminals

- (Refer to the Crimping Terminal 1 or 2 shown in the drawing below.)
- HS1C
Terminals No. 1 to 6: Use solid or stranded wires only (crimping terminals not applicable).
Terminals No. 7 and 8: Crimping Terminal 1
Ground Terminal: Crimping Terminal 2
- HS1B
Ground Terminal: Crimping Terminal 2
Other Terminals: Crimping Terminal 1
HS2B, HS5B, and HS1E
Crimping Terminal 1

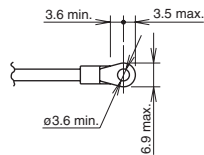

Crimping Terminal 1

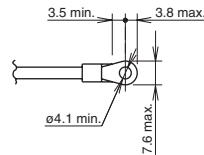

Crimping Terminal 2

Use an insulation tube on the crimping terminal.

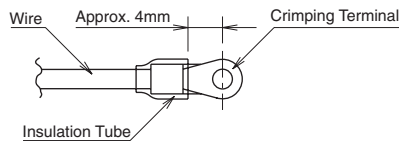

Installation Examples (see the diagrams below)

Mounting on Sliding Doors

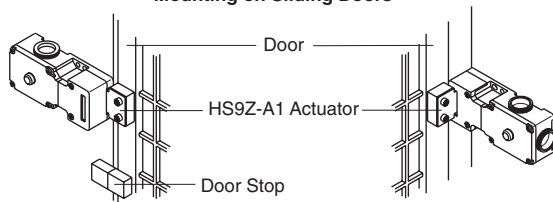

Mounting on Hinged Doors

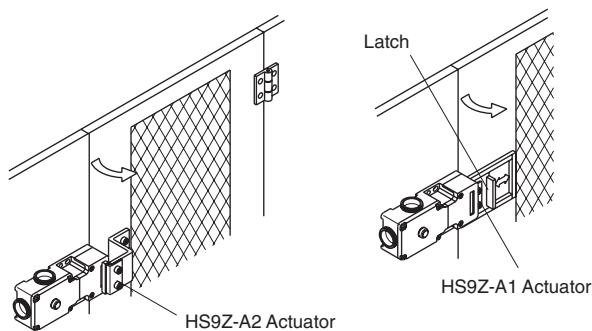

Applicable Connectors (As shown below)

- Use connectors which maintain the IP67 protection.
- Applicable Connector Dimensions
- Flex Conduit: VF03 (Japan Flex) www.nipolex.co.jp
- Steel Connector (G1/2): ALC-103 (PF13.5): RBC-103PG13.5

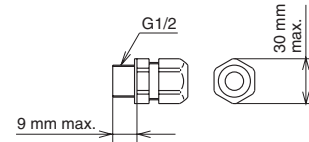

Recommended Screw Tightening Torque

- HS1C: 5.0±0.5 N-m (approx. 50±5 kgf-cm)
(4 or 6 pcs of M5 hex socket head cap screws)
- HS1B: 5.0±0.5 N-m (approx. 50±5 kgf-cm)
(2 or 4 pcs. of M5 hex socket head cap screws)
- HS2B: 5.0±0.5 N-m (approx. 50±5 kgf-cm)
(2 pcs of M5 hex socket head cap screws)
- HS5B: 4.0±0.4 N-m (approx. 40±4 kgf-cm)
(2 pcs of M4 hex socket head cap screws)
- HS1E: 5.0±0.5 N-m (approx. 50±5 kgf-cm)
(4 or 6 pcs of M5 hex socket head cap screws)
- Actuator (HS9Z-A1/A2)
5.0±0.5 N-m (approx. 50±5 kgf-cm)
- (2 pcs. of M6 hex socket head cap screws)
Actuator (HS9Z-A51/A52)
- 2.0±0.2 N-m (approx. 20±2 kgf-cm)
(2 pcs of M4 hex socket head cap screws)
- 1.0±0.2 N-m (approx. 10±2 kgf-cm)
(2 pcs of M4 Phillips screws)

The screws are supplied by the user.

Applicable Wire Size

- HS1C: 0.5 to 0.75 mm² (Terminals No.1, 2, 5 to 8)
1.0 to 1.25 mm² (Terminals No.3, 4, and grounding terminal)
- HS5B: 0.5 to 1.25 mm²
- HS1E: 0.5 to 1.25 mm²

Actuator Angle Adjustment

- Using the screw (M3 hex socket head screw), the actuator angle can be adjusted (refer to the dimensional drawing). Adjustable angle: (0°) to 20°
- The larger the adjusted angle of the actuator, the smaller the applicable radius of the door opening.

- After installing the actuator, open the door. Then adjust the actuator so that its edge can be inserted properly into the entry slot of the safety switch.
- Recommended tightening torque: 0.8 N-m (approx. 8.0 kgf-cm)
- After adjusting the actuator angle, apply loctite or the like to the adjustment screw so as to prevent its loosening.

Minimum Radius of Hinged Door

- When using the interlock switch on hinged doors, refer to the minimum radius of doors shown below. When using on doors with small minimum radius, use the angle adjustable actuator (HS9Z-A55).

Note: Because deviation or dislocation of hinged doors may occur in actual applications, make sure of the correct operation before installation.

When using the HS9Z-A52 Actuator

- When the door hinge is on the extension line of the interlock switch surface:

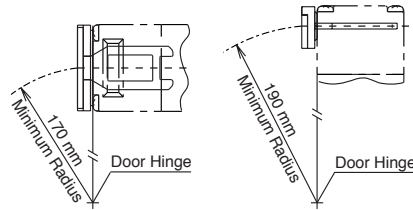

- When door hinge is on the extension line of the actuator mounting surface:

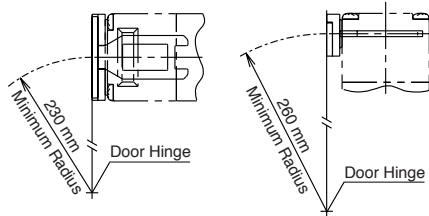

When using the HS9Z-A55 Angle Adjustable Actuator

- When door hinge is on the extension line of the interlock switch surface: 50 mm
- When door hinge is on the extension line of the actuator mounting surface: 70 mm

Horizontal Swing

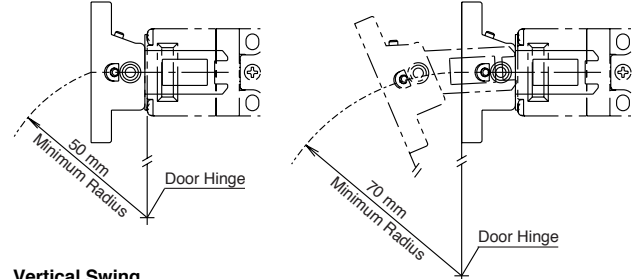

Vertical Swing

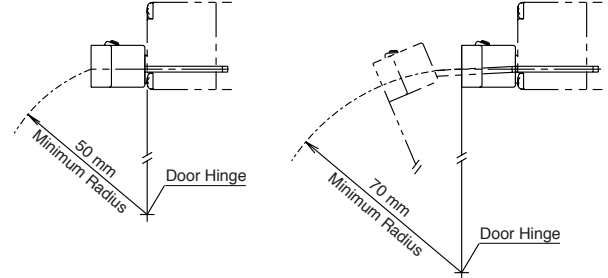

Actuator Angle Adjustment for the HS9Z-A55

- Using the angle adjustment screw, the actuator angle can be adjusted (see figures on page 370). Adjustable angle: 0 to 20°
- The larger the adjusted angle of the actuator, the smaller the applicable radius of the door opening.
- After installing the actuator, open the door. Then adjust the actuator so that its edge can be inserted properly into the actuator entry slot of the interlock switch.
- After adjusting the actuator angle, apply Loctite to the adjustment screw so that the screw will not loosen.

Applicable Cable Glands

Use a cable gland with a degree of protection IP67

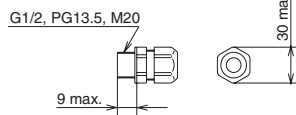

all dimensions in mm

When Using Flexible Conduits (Example)

Flexible conduit example: VF-03 (Nihon Flex)

Conduit Port Size	Plastic Cable Gland	Metal Cable Gland
G1/2	—	RLC-103 (Nihon Flex)
PG13.5	—	RBC-103PG13.5 (Nihon Flex)
M20	—	RLC-103EC20 (Nihon Flex)

When Using Multi-core Cables (Example)

Conduit Port Size	Plastic Cable Gland	Metal Cable Gland
G1/2	SCS-10* (Seiwa Electric)	ALS-16** (Nihon Flex)
PG13.5	ST13.5 (K-MECS)	ABS-**PG13.5 (Nihon Flex)
M20	ST-M20X1.5 (K-MECS)	ALS-**EC20 (Nihon Flex)

- Different cable glands are used depending on the cable sheath outside diameter. When purchasing a cable gland, confirm that the cable gland is applicable to the cable sheath outside diameter.
- When using a 1/2-14NPT cable gland, use the HS5B interlock switch with M20 conduit port (Part No.: HS5B-***BM) together with an adapter (Part No.: MA-M/NPT 20X1.5 5402-0110, K-MECS) and a gasket (Part No.: GP M20, K-MECS). Install a gasket between the interlock switch and the adapter. Apply sealing tape between the cable gland and the adapter to make sure of IP67 protection for the enclosure.