

EASY TO USE TELEMETRY SYSTEM USING ALPHA MODULES

Features

- 3 digital I/O
- Serial Data output
- Connects directly to ALPHA Modules
- Easy Enc / Dec Pairing Function
- Receiver Acknowledge Signal
- Minimal External Components Required
- Performs all encoding/decoding of data for Reliable Operation
- Fast Activation / Deactivation Time
- Up to 30 Transmitter Pairings
- Sleep mode, for battery saving
- One to many / many to one relationship.

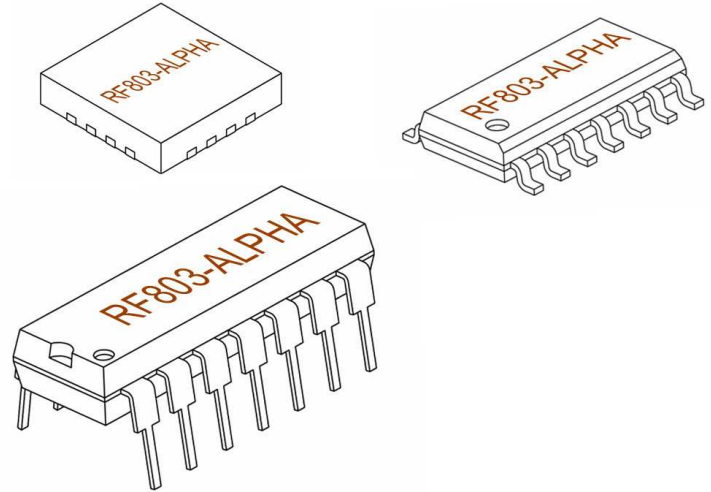

Applications

- Remote control
- Radio Telemetry
- RFID

Description

The RF803E/D-ALPHA series are powerful yet simple encoder and decoder devices. When combined with an RF Solutions Ltd Alpha Module they may be used to create a remote control system with up to 3 I/O lines. The RF803E/D-ALPHA also offer a feedback function when used with ALPHA-TRX (transceiver) module they can acknowledge all transmissions for ultimate reliability.

The decoder IC incorporates an 'easy learn' pairing procedure to create a relationship between encoder and decoder.

RF803 Series ICs perform all the necessary data manipulation and encoding/decoding of data for an optimum range reliable radio link whilst providing a simple user interface.

Part Number	Description	Packages available
RF803E-ALPHA RF803E-ALPHA-SO RF803E-ALPHA-SOT RF803E-ALPHA-Q	Encoder IC	14 pin PDIP SOIC Tape & Reel 16 pin QFN
RF803D-ALPHA RF803D-ALPHA-SO RF803D-ALPHA-SOT RF803D-ALPHA-Q	Decoder IC	14 pin PDIP SOIC Tape & Reel 16 pin QFN

Transmitter Encoder RF803E-ALPHA

Functional Description

The RF803E-ALPHA is a simple device to use. As shown in the application circuit below, it requires only the addition of input switches and an ALPHA-TRX RF Module for use as the transmitter in an end application. Transmission is automatic without user intervention.

The ID is designed to run in continuous sleep mode; on detecting a switch closure The RF803E-ALPHA will wake up transmit a secure data packet on the TX output.

The RF803E-ALPHA can be set as a simple transmit device, or, to expect an acknowledgement signal back from the decoder.

The type of transmissions to send may also be configured

- Transmit only on state change,
- Transmit continuously whilst input is active.

Block Diagram

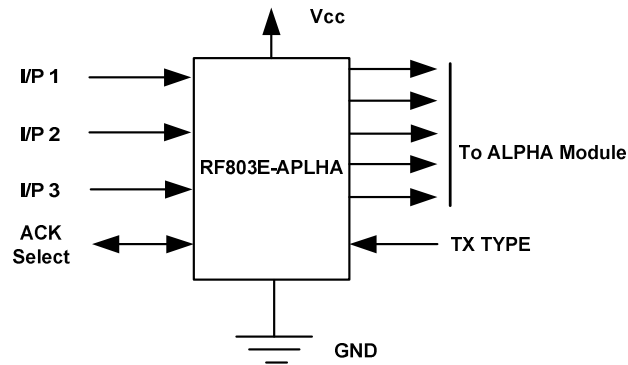

Pin Descriptions RF803E-ALPHA

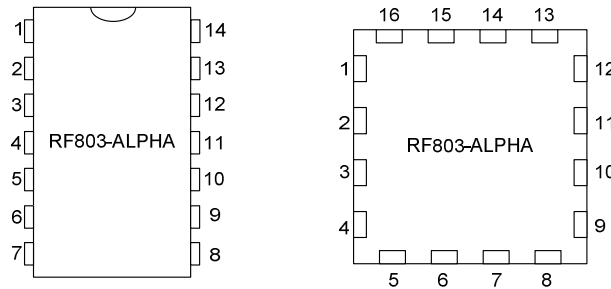

SOIC/PDIP

Pin Number	Name	Input / Output	Description
1	VDD	-	Voltage in +3.3V
2	ACK LED	O/P	ACKNOWLEDGE FAILED (ACTIVE HIGH)
3	TX LED2	O/P	TX LED (ACTIVE HIGH)
4	ACK	I/P (*)	ACKNOWLEDGE REQUEST (ACTIVE LOW)
5	CONT	I/P (*)	CONTINUOUS TX (ACTIVE LOW)
6	CLK	O/P	Clock TO ALPHA MODULE Pin 13
7	IRQ	I/P	TO ALPHA MODULE Pin 2
8	SDI	I/P	Serial Data In TO ALPHA MODULE Pin 1
9	SDO	O/P	Serial Data Out TO ALPHA MODULE Pin 12
10	SEL	O/P	TO ALPHA MODULE Pin 14
11	I/P3	I/P	Input 3
12	I/P2	I/P	Input 2
13	I/P1	I/P	Input 1
14	Vss	-	Ground

VQFN

Pin Number	Name	Input / Output	Description
1	ACK LED	O/P	ACKNOWLEDGE FAILED (ACTIVE HIGH)
2	TX LED2	O/P	TX LED (ACTIVE HIGH)
3	ACK	I/P (*)	ACKNOWLEDGE REQUEST (ACTIVE LOW)
4	CONT	I/P (*)	CONTINUOUS TX (ACTIVE LOW)
5	CLK	O/P	Clock TO ALPHA MODULE Pin 13
6	IRQ	I/P	TO ALPHA MODULE Pin 2
7	SDI	I/P	Serial Data In TO ALPHA MODULE Pin 1
8	SDO	O/P	Serial Data Out TO ALPHA MODULE Pin 12
9	SEL	O/P	TO ALPHA MODULE Pin 14
10	I/P3	I/P	Input 3
11	I/P2	I/P	Input 2
12	I/P1	I/P	Input 1
13	Vss	-	Ground
14			DO NOT CONNECT
15			DO NOT CONNECT
16	VDD	-	Voltage in +3.3V

(*) Pull up / Pull Down required.



IP 1-3

These are the switch inputs which when operated wake up the RF803E-ALPHA and cause transmission. They may be switched directly to Ground. Transmission occurs for the duration of the switch operation.

ACK FAILED LED

This Output is normally low, asserted High when a transmission fails. A transmission is re-tried 5 times when an acknowledgement is not immediately received. If none is received after the 5 re-try attempts, the Output will be asserted.

TX LED

While transmitting the TX output will toggle at high frequency (flicker LED) when the transmission is finished the output will be asserted continuously for 2 seconds to show that an acknowledgement has been received.

ACK – Acknowledge Request

This pin is used to set an acknowledgement request from the Receiver or not.
Only enable when using TRX modules.

CONT – Continuous TX

Low: in this mode the RF803E-ALPHA will transmit continuously while an input is asserted,

And stop when it is released.

High: In this mode the RF803 will transmit only when an input changes state.

Vcc

The power supply needs to be a stable regulated voltage between 2.5 and 5.5V with <10mV ripple. Note that in idle mode the transmitter current drain is typically only 100nA.

GND

Ground connection



Receiver Decoder RF803D-ALPHA

Functional Description

The RF803D-ALPHA is simple to use. As shown in the typical application circuit below, the RF803D-ALPHA has the capability to learn up to 30 unique RF803E-ALPHA transmitters.

The digital outputs may be configured as latching or momentary action.

Latch = the output will change state on each successive transmit of the encoder.

Momentary = the output will only operate for as long as the RF803E-ALPHA encoder is transmitting.

The RF803D-ALPHA can be configured to work with an ALPHA TRX or TX by setting the TX/TRX pin.

Block Diagram

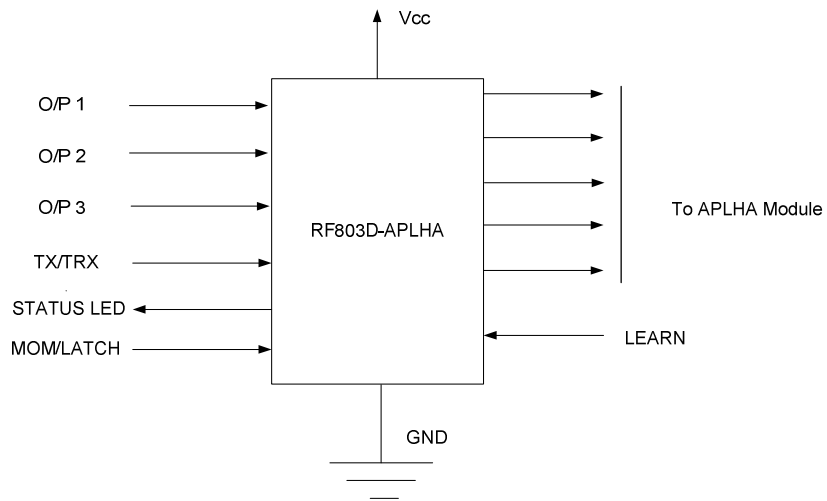

Pin Descriptions RF803D-ALPHA

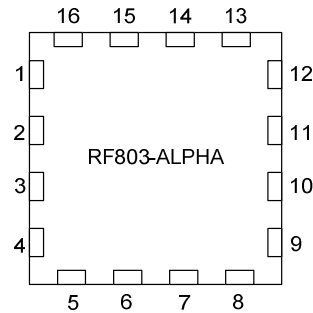
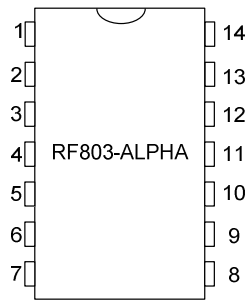

SOIC / PDIP

Pin Number	Name	Input / Output	Description
1	VDD	-	Voltage in +3.3V
2	LRN BTN	I/P	Learn button input
3	LRN LED	O/P	Learn / RX LED
4	MOM/LATCH	I/P (*)	Momentary / Latching select
5	SERIAL O/P	O/P	Serial data output (Low level)
6	CLK	O/P	TO ALPHA MODULE Pin 13
7	IRQ	I/P	TO ALPHA MODULE Pin 2
8	SDI	I/P	TO ALPHA MODULE Pin 1
9	SDO	O/P	TO ALPHA MODULE Pin 12
10	SEL	O/P	TO ALPHA MODULE Pin 14
11	O/P 3	O/P	Output 3 (20mA max)
12	O/P 2	O/P	Output 2 (20mA max)
13	O/P 1	O/P	Output 1 (20mA max)
14	VSS	-	Ground

(*) Pull up / Pull Down required.

QFN

Pin Number	Name	Input / Output	Description
1	LRN BTN	I/P	Learn button input
2	LRN LED	O/P	Learn / RX LED
3	MOM/LATCH	I/P	Momentary / Latching select
4	SERIAL O/P	O/P	Serial data output (Low level)
5	CLK	O/P	TO ALPHA MODULE Pin 13
6	IRQ	I/P	TO ALPHA MODULE Pin 2
7	SDI	I/P	TO ALPHA MODULE Pin 1
8	SDO	O/P	TO ALPHA MODULE Pin 12
9	SEL	O/P	TO ALPHA MODULE Pin 14
10	O/P 3	O/P	Output 3 (20mA max)
11	O/P 2	O/P	Output 2 (20mA max)
12	O/P 1	O/P	Output 1 (20mA max)
13	Vss	-	Ground
14			DO NOT CONNECT
15			DO NOT CONNECT
16	VDD	-	Voltage in +3.3V

**Vcc**

2.5-5.5V DC input. The power supply needs to be a stable regulated voltage with <10mV ripple

GND

Ground connection.

OP1-3

These outputs are asserted LOW when the relevant inputs (I/P1 – I/P3) on the RF803E-ALPHA are asserted.

RX LED

While a valid signal is present the Learn/RX LED output will toggle at high frequency (flicker LED)

Note that this output will be valid whether or not, the RF803E-ALPHA has been learnt to the RF803D-ALPHA or not

LRN

This input is used to set the decoder module to 'Learn Mode' and for the 'Erase Function' and is also used to drive the Status LED.

OP TIMING

This pin is read on power up to sets the action of outputs 1-3. Latching is set using connection to Vcc via a 250K resistor (R8). Momentary is set by connecting direct to GND .This may need to be dropped to 10K in noisy environments.

SERIAL

In normal run mode this pin outputs serial data on reception of a valid data string, this pin will output any valid serial data packet regardless of learn status.



Application Circuit

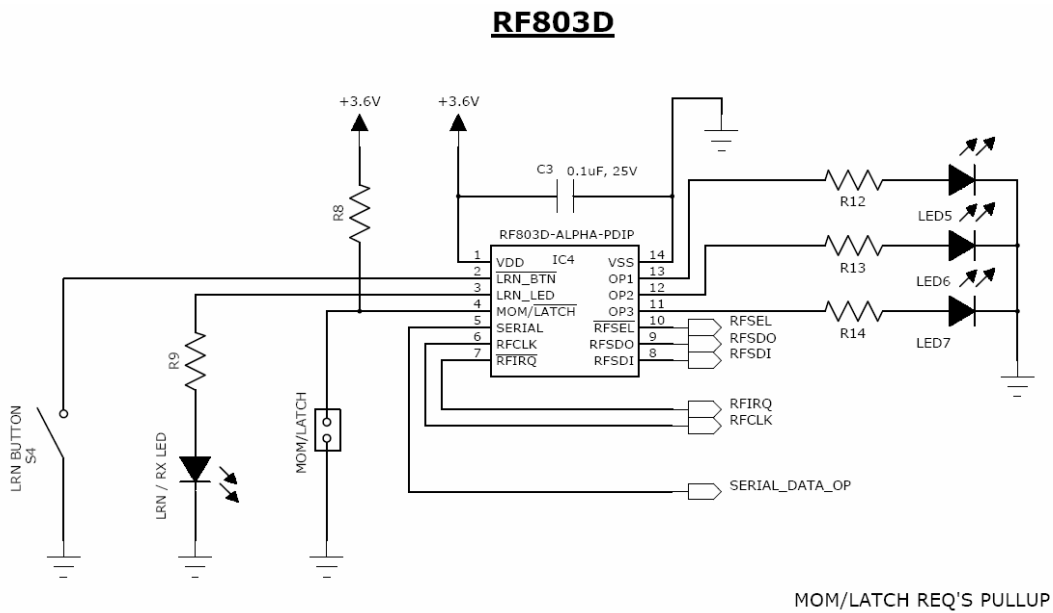

Connecting to your ALPHA module:

ALPHA MODULE

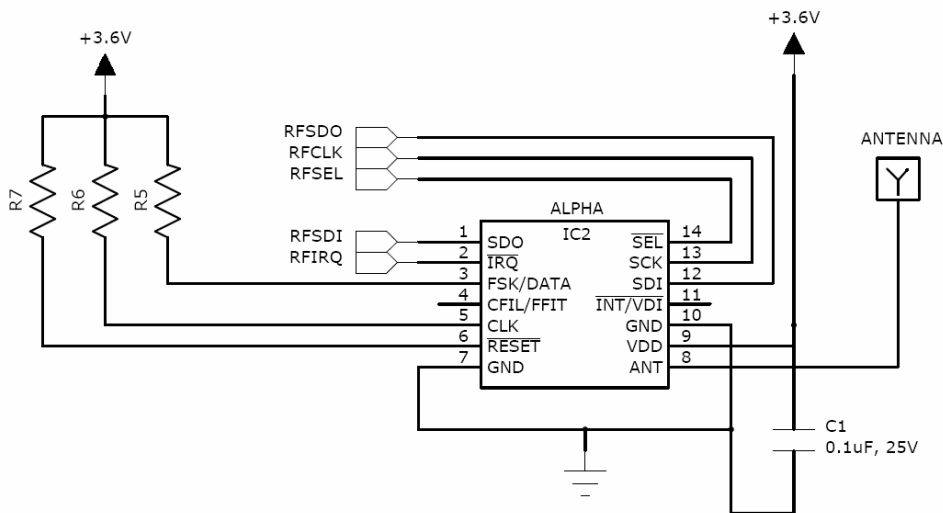

System and Functional operation

Pairing a Transmitter to a Receiver

Each transmitter is supplied a unique identity. Each time a switch is pressed, the transmitter emits a highly secure RF signal with its identity embedded within. The Receiver can learn this signal and allocate to an output.

Each transmitter input may be individually paired to each individual or combination of the receiver's outputs. This enables a powerful and flexible remote control system!

The only limitation is that each receiver has a maximum capacity of 50 pairings, these can be from the same or any number of transmitters.

Hint: the same transmitter may be taught to any number of receivers to create 'master keys'.

Learn Mode: Learn input activation is achieved by pulling this input to GND briefly

To learn a new transmitter switch follow this procedure (as application circuit)

Any Encoder input can be learnt to one or many of the receiver outputs.

Each input must be learnt to each output individually by following this procedure:

1. Select the receiver output to learn:
 - a. Briefly operate the receiver Learn switch (SW1) once
 - b. The Learn LED will flash once to indicate that output 1 is selected
 - c. After the LED stops flashing, press the Learn switch again to select the next output channel
 - d. Repeat step c until the required output is selected.
2. Operate whichever input on the encoder you want to learn to the selected decoder output.
3. The Learn LED will then illuminate, within 10secs, operate the same encoder input again.
4. The Learn LED will then flash to indicate learning is complete.

Erase Mode (As application circuit): is achieved by pulling this input to GND for >8 seconds. This causes the internal EEPROM to be erased of all pre-learnt RF803E-ALPHA encoders. During Erase the Learn LED will activate, it will extinguish when erase is complete.

Mom / Latch

This high impedance input is used to set the digital outputs to momentary or latched actions. Pull up / Pull down required.

LKIN Status	Digital Outputs Function
HIGH	Momentary
LOW	Latching

Continuous Transmit or State change transmit

The RF803E-ALPHA can be set to transmit only on a state change – when it will send 3 data packets each time it receives a state change on its inputs – or to transmit continuously while an input is active. This enables the RF803E-ALPHA to be used in applications with momentary inputs or latching inputs.

NOTE: TRX acknowledge can only be sent AFTER a transmission. Therefore when using TRX mode and Continuous Transmit mode an acknowledge is sent when the transmission has finished. When using TRX mode and State Change Transmit the acknowledgement is sent 500ms after the first packet is received by the RF803D-ALPHA.



Serial Data Output

The RF803D-ALPHA has a serial data output. This outputs the serial number, button and battery status of the transmitter encoder (RF803E-ALPHA). This data may be fed directly to a microcontroller or RS232 type driver circuit which may then be fed directly to a PC serial port. Serial data is output initially and again on every state change whilst data is being received from the RF803E-ALPHA transmitter. i.e. this output is valid regardless of whether the RF803E-ALPHA encoder has been learnt to the RF803D-ALPHA decoder or not. The serial data packet contains a learn bit to show if an encoder input is learnt.

Serial Data Format

Serial Data is sent on every state change as a stream of 8 bytes at 19.2K baud. The serial data format is: 8 data bits with 1 stop bit, no parity.

Serial data is output from the Decoder chip whenever a valid data packet from an RF800n or other compatible RF Solutions transmitter is received regardless of learn

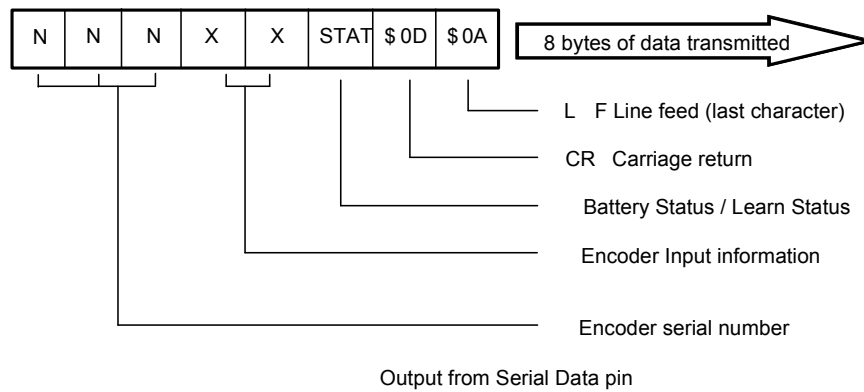

Encoder Serial Number [NN]: made up of two 8-bit bytes where the most significant byte is transmitted first.

This provides a total of 65,536 possible serial numbers.

Example: 12AB (hexadecimal) or 0001 0010 1010 1011 (binary)





Encoder Input Information [XX]: made up of two 8-bit bytes.

The high order byte is sent first representing inputs 16 down to 9 where the MSb is input 16 and the LSb is input 9.

The low order byte is sent next representing inputs 8 down to 1 where the MSb is input 8 and the LSb is input 1.

A bit at state 1 represents an encoder input as active.

Using this method inputs can be multiplexed giving maximum versatility.

Example: 00000000 00001000 - Shows input 4 active.
00000001 00000000 – Shows input 9 active
10000001 00000001 – Shows inputs 16, 9 and 1 active

Status [STAT]: The status byte is made up of an 8-bit byte as follows:

<i>BIT</i>	<i>Description</i>	<i>Details</i>
Bit-7 down to 2	Reserved	For future usage
Bit 1	Learn status	1 = encoder has been learnt
Bit 0	Not Used	0 = Always

Example: 00000010 = encoder battery ok, encoder has been learnt
00000001 = encoder battery low, encoder has not been learnt

Carriage Return [CR] and Line feed [LF]

To mark the end of the serial packet ascii characters for carriage return (hex 0D) are sent followed by LF (hex 0A).

Custom Versions

Custom versions of the RF803E-ALPHA / RF803D-ALPHA chipset are available to provide a bespoke remote chipset for OEM applications. Please contact our sales department for further information.

***NOTE: Serial Data output is common across the entire RF80n range, therefore up to 16 inputs states are sent. When using encoders with lower numbers of inputs the un-used bits are set to 0.**

**R. F. Solutions Ltd.,
Unit 21, Cliffe Industrial Estate,
Lewes, E Sussex, BN8 6JL, England
Tel +44 (0)1273 898 000 Fax +44 (0)1273 480 661
Email sales@rfsolutions.co.uk
<http://www.rfsolutions.co.uk>**

All Trademarks acknowledged and remain the property of the respected owners.

Information contained in this document is believed to be accurate, however no representation or warranty is given and R.F. Solutions Ltd. assumes no liability with respect to the accuracy of such information. Use of R.F. Solutions as critical components in life support systems is not authorised except with express written approval from R.F. Solutions Ltd.





Technical Specifications:

Absolute Maximum Ratings 803E and 803D

Note: Stresses above those listed under "Absolute Maximum Ratings" may cause permanent damage to the device.

Item	Rating	Units
Supply voltage	2.0 – 5.5	V
Max output current	80	mA
Storage temperature	-65 to +150	°C (Note)
Lead soldering temp		°C (Note)
ESD rating		V
Max O/P current sunk by any I/O pin	25	mA
Max O/P current sourced by any I/O pin	75	mA

RF803E-ALPHA

Electrical Characteristics	Min	Typical	Max	Unit
Operating current(average) Vdd = 5V	603	645	689	µA
Standby current		.1		µA
High level Input voltage	2.0		VDD	V
Low level input voltage	VSS		0.8	V
High level output voltage	VDD - .7			V
Low level output voltage			0.6	V
Output Pin Current rating			25	mA
LED sink current			75	mA

RF803D-ALPHA

Electrical Characteristics	Min	Typical	Max	Unit
Operating current(average) Vdd = 5V				mA
Standby current				µA
High level Input voltage				V
Low level input voltage	VSS		0.8	V
High level output voltage	VDD - .7			V
Low level output voltage			0.6	V
Output Pin Current rating			25	mA
LED sink current			75	mA



Appendix – Package types

16 PIN QFN PACKAGE

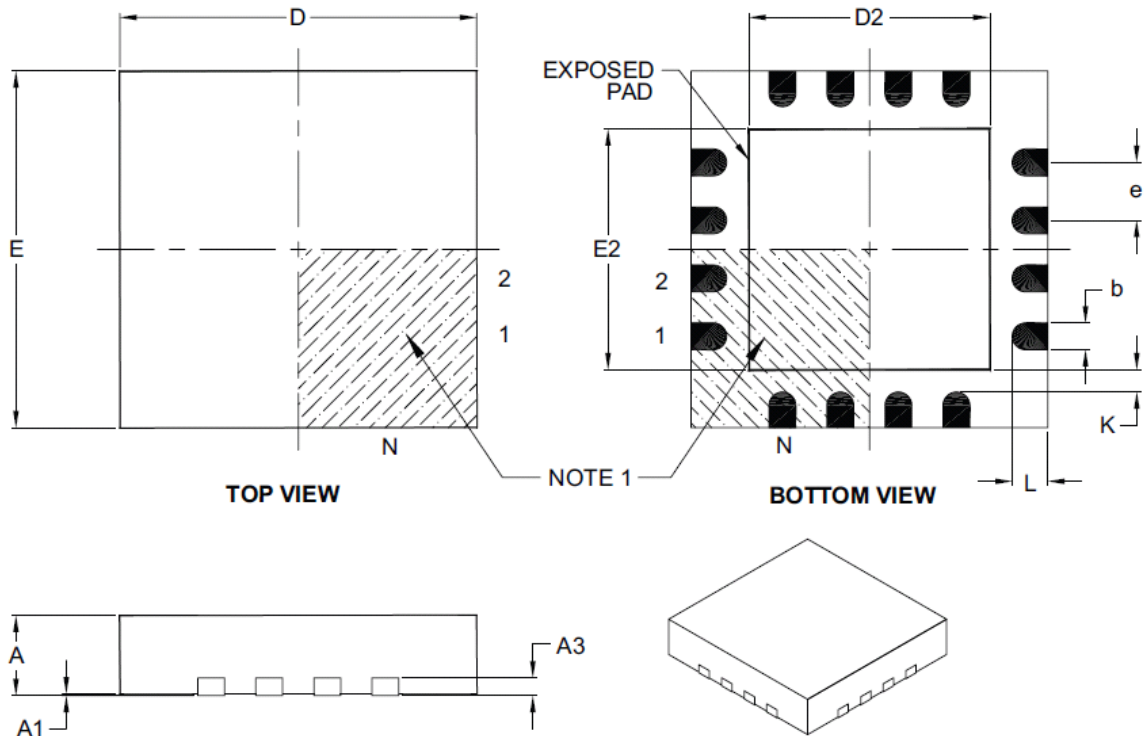

Dimension Limits	Units	MILLIMETERS		
		MIN	NOM	MAX
Number of Pins	N	16		
Pitch	e	0.65 BSC		
Overall Height	A	0.80	0.90	1.00
Standoff	A1	0.00	0.02	0.05
Contact Thickness	A3	0.20 REF		
Overall Width	E	4.00 BSC		
Exposed Pad Width	E2	2.50	2.65	2.80
Overall Length	D	4.00 BSC		
Exposed Pad Length	D2	2.50	2.65	2.80
Contact Width	b	0.25	0.30	0.35
Contact Length	L	0.30	0.40	0.50
Contact-to-Exposed Pad	K	0.20	-	-

Notes:

- Pin 1 visual index feature may vary, but must be located within the hatched area.
- Package is saw singulated.
- Dimensioning and tolerancing per ASME Y14.5M.

BSC: Basic Dimension. Theoretically exact value shown without tolerances.

REF: Reference Dimension, usually without tolerance, for information purposes only.

14 PIN SOIC PACKAGE

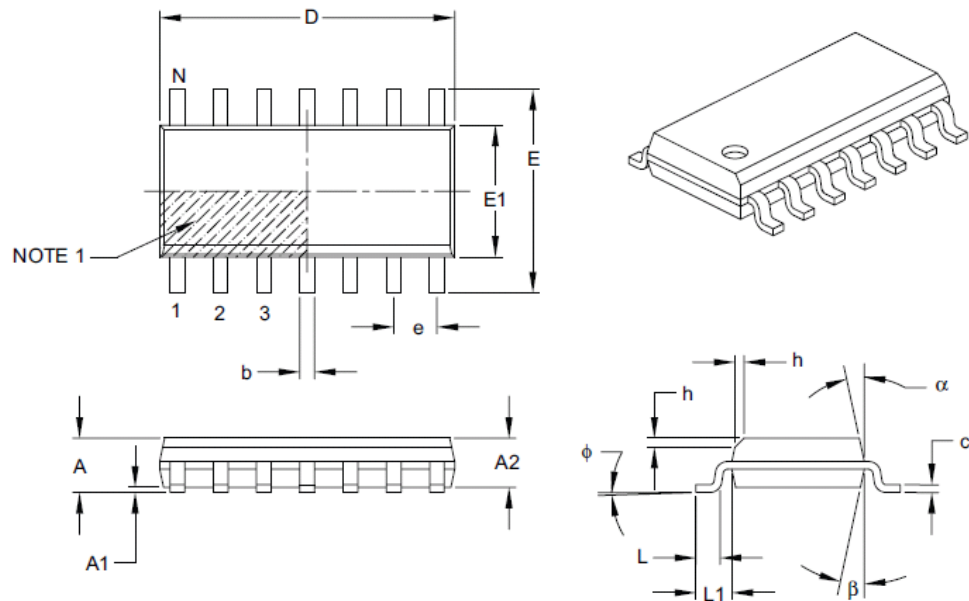

Dimension Limits	Units	MILLIMETERS		
		MIN	NOM	MAX
Number of Pins	N	14		
Pitch	e	1.27 BSC		
Overall Height	A	–	–	1.75
Molded Package Thickness	A2	1.25	–	–
Standoff §	A1	0.10	–	0.25
Overall Width	E	6.00 BSC		
Molded Package Width	E1	3.90 BSC		
Overall Length	D	8.65 BSC		
Chamfer (optional)	h	0.25	–	0.50
Foot Length	L	0.40	–	1.27
Footprint	L1	1.04 REF		
Foot Angle	ϕ	0°	–	8°
Lead Thickness	c	0.17	–	0.25
Lead Width	b	0.31	–	0.51
Mold Draft Angle Top	α	5°	–	15°
Mold Draft Angle Bottom	β	5°	–	15°

Notes:

- Pin 1 visual index feature may vary, but must be located within the hatched area.
- § Significant Characteristic.
- Dimensions D and E1 do not include mold flash or protrusions. Mold flash or protrusions shall not exceed 0.15 mm per side.
- Dimensioning and tolerancing per ASME Y14.5M.

BSC: Basic Dimension. Theoretically exact value shown without tolerances.

REF: Reference Dimension, usually without tolerance, for information purposes only.

14 PIN PDIP PACKAGE

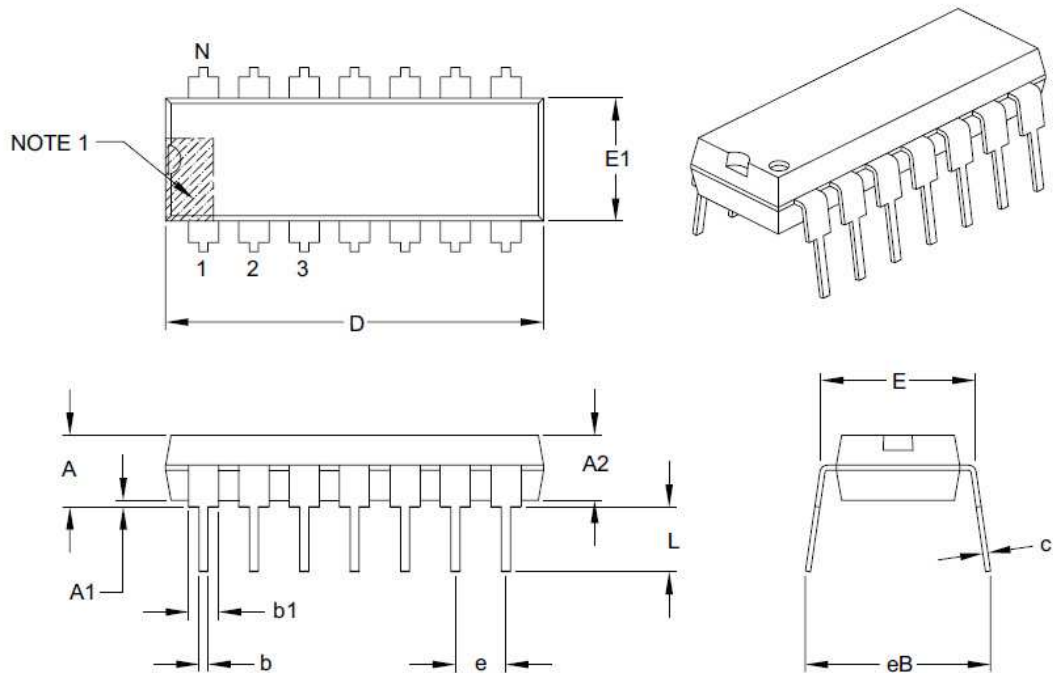

Dimension Limits	Units	INCHES		
		MIN	NOM	MAX
Number of Pins	N	14		
Pitch	e	.100 BSC		
Top to Seating Plane	A	–	–	.210
Molded Package Thickness	A2	.115	.130	.195
Base to Seating Plane	A1	.015	–	–
Shoulder to Shoulder Width	E	.290	.310	.325
Molded Package Width	E1	.240	.250	.280
Overall Length	D	.735	.750	.775
Tip to Seating Plane	L	.115	.130	.150
Lead Thickness	c	.008	.010	.015
Upper Lead Width	b1	.045	.060	.070
Lower Lead Width	b	.014	.018	.022
Overall Row Spacing §	eB	–	–	.430

Notes:

1. Pin 1 visual index feature may vary, but must be located with the hatched area.
2. § Significant Characteristic.
3. Dimensions D and E1 do not include mold flash or protrusions. Mold flash or protrusions shall not exceed .010" per side.
4. Dimensioning and tolerancing per ASME Y14.5M.

BSC: Basic Dimension. Theoretically exact value shown without tolerances.