



Zulu 2km Radio Link

Features

- RF serial Data upto 2KM Range
- Serial Data Interface with Handshake
- Host Data Rates up to 38,400 Baud
- RF Data Rates to 56Kbps
- 5 User Selectable Channels
- Secure Data Protocol
- CE Compliant for Licence Free Use
- 868MHz or 915MHz Versions



The ZULU*Arduino* provides a radio (Modem) link with easy interface to for upto 2KM range. Range may be further extended with suitable antenna.

All RF operation is auto controlled (with error checking etc) so the ZULU*Arduino* can be treated as a simple Communications device. This shield is also compatible with the RF Solutions Blizzard Modem.

The shield is ready to plug and play with default setting serial port set to 4800, 8 Bits, No Parity, 1 Stop Bit (Hardware CTS / RTS)

To get up and running quick, there is ready written code available for download at

www.rfsolutions/knowledgebase

Shield Connections:

Output Pins

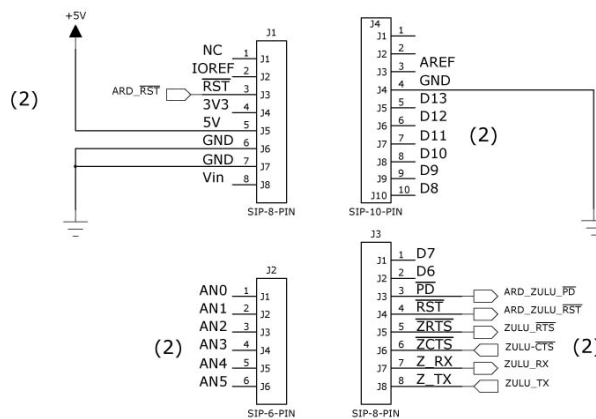

Shield Description

Serial Data Format

Baud Rate: Defined by DR1 and DR2 Pins
Data Bits: 8, No Parity, 1 Stop Bit
Flow Control: Hardware CTS / RTS

CTS, RTS

Clear to Send and Request to Send are standard data flow control used in RS232 systems, these are standard but operate at the Zulu Vcc low level voltage.

If no handshaking required RTS (Arduino D3) may be pulled low, however beware of data overrun errors of transmitting streams of data longer than the data buffer!

RESET

If J5 (1-2, 3-4) are unconnected Reset and PD are disabled.

If J5 (1-2, 3-4) are connected Reset and PD are enabled and controlled by Arduino.

DR1 - DR2

These inputs define the host interface Baud Rate. They are read when RESET pin goes high.

Tip: It is good practice to operate the host interface at half the speed of the RF data rate (set by Register R5)

DR1	DR2	Host Baud Rate
Vcc / Unconnected	Vcc / Unconnected	4,800
Vcc / Unconnected	GND	9,600
GND	Vcc / Unconnected	19,200
GND	GND	38,400

PD

This input enables 'Sleep' Mode. For normal operation connect to Vcc. No RF packets will be received by the module when it is in sleep mode.

WRE

Controls where the User configuration parameters are saved in internal EEPROM (Non-Volatile) or RAM (Volatile) Un-used. This may be ignored unless the application requires specific address timing on powerup.

Operation Overview

The ZULU MODEM Module provides a simple Modem interface to the host controller. It handles all RF data communications automatically and without any requirement from the user (RF packetizing , Preamble, Encoding, CRC Check etc).

With this powerful high-speed Radio link. The following networks can be realised;

One-to-One operation; for point to point data communication

One-to-Many; A network consisting a master and many slaves (the receivers all have the same address)

Many-to-One; where the transmitters all send to a single receiver address.

Because each ZULU MODEM can contain a unique address, multiple ZULU networks can co-exist in the same area.

Broadcast operation; where a single master Zulu MODEM addresses many ZULU MODEMS concurrently. (using many ZULU MODEM modules set to the same address),

Operating Modes

Configuration Mode: In Configuration mode the Zulu MODEM can receive a number of commands and the internal registers can be preset to control its operation. In this mode the Zulu MODEM is 'Offline' and cannot send or receive RF data.

Normal Operation : ZULU MODEM is 'Online' automatically transmitting and receiving data from its host and across the RF network.

Each ZULU MODEM has its own preset address. This is user set during configuration. Any data received is examined and the address header embedded within the data packet is compared with its address. Only data received with matching address will be processed and output to the host, all other data will be discarded.

All ZULU MODEM modules are shipped with a default address of 7F7F7F.

The ZULU MODEM contains an on-board data buffer equal to two data packets. Therefore if RTS is asserted (then the host is unable to receive data) the module will store a max of two data packets, all further data packets received will be discarded.

Configuration Mode (offline)

Commands can be set using a standard Terminal program or by sending the relevant ASCII characters.

Each Command must be followed by the Carriage Return <CR> or 'Enter'

Note All commands are entered in upper case

Command	Description	Response from Zulu
+++	Enter Configuration Mode Note: these must be sent as a string with no char in front or behind this is to ensure that the +++ is not mistakenly received in mid data.	Zulu responds with Status info
?	retrieve the current register values	Zulu responds with all Register Values
F	set factory defaults; R1=7F7F7F R2=7F7F7F R3 = Ch2 (869.450MHz) R4 = 7 (+20dBm) R5 = 1 (19K2)	'OK'
H	Help	Brief description of commands available
P	Ping Mode This sends a ping request . On receiving, the recipient Zulu Modem will respond with its address and the level of RSSI (Received Signal Strength) The Ping command is continuously repeated every 1 second until any command or character is entered.	The originating Zulu Modem will respond with the Recipient Zulu Modems' response, eg. Received from 7F7F7F (D5) Where 7F7F7F = the recipient Address D5= RSSI RSSI Is a Hex value corresponding to the received signal strength Min = 20hex Max =E0hex
S S	Save Configuration	'SAVED'
Q	exit configuration mode and return to online mode	No response

Register Setting (Configuration Mode)

The internal registers enable various parameters to be controlled.

To set a register type 'R#=x' where # is the register number (1-6) and x is the value to set

For example, to set the channel to channel 3 type the following.

R3=3<CR>

(Where <CR> is carriage return or enter on the keyboard) The modem will then return 'OK' or 'Error' if an incorrect command is entered. Save the changes by typing

S<CR>

The modem will return with 'SAVED'

Register	Value Range	Description	Example
R1	0000 - FFFFFFFF (24 bit address)	Sets the recipient Zulu MO-DEM Address	R1=0001 (Data sent is addressed to Zulu MODEM with address 0001)
R2	0000 - FFFFFFFF (24 bit address)	Set own Zulu Modem address	R2=F001 (Data sent is from Zulu MODEM with address F001)
R3	CH0 = 868.400 MHz CH1 = 868.900 MHz CH2 = 869.450 MHz CH3 = 869.600 MHz CH4 = 869.800 MHz	Set RF channel	R3=2 (Transmit on Channel 2)
R4	0 = +1dBm 1 = +2dBm 2 = +5dBm 3 = +8dBm 4 = +11dBm 5 = +14dBm 6 = +17dBm 7 = +20dBm	Set the RF Transmit Power output*	R4=7 (sets Transmit Power to max)*
R5	0 = 9,600 1 = 19,200 2 = 28,800 3 = 56,000	Set the RF baud rate*	R5=3 (sets the RF data rate to 56Kbps)

Channel Number	Frequency Centre (MHz)	EU Power Allowance mW / dBm	Notes
0	868.400	25 / 14	Applicable standard - EN300-220
1	868.900	25 / 14	
2	869.450	100 / 20	
3	869.600	100 / 20	
4	869.800	25 / 14	

Notes on power and frequency

The EU standard sets maximum power transmission limits dependent on the frequency, the bandwidth and the application. Please check the relevant standards are being met when implementing your RF Application. A rough guidance applicable to the ZULU channel numbers is given below

*Note : Reducing Tx power reduces battery consumption!
Reducing the baud rate will increase the range!



RF Solutions Ltd. Recycling Notice

Meets the following EC Directives:

DO NOT Discard with normal waste, please recycle.

ROHS Directive 2002/95/EC

Specifies certain limits for hazardous substances.

WEEE Directive 2002/96/EC

Waste electrical & electronic equipment. This product must be disposed of through a licensed WEEE collection point. RF Solutions Ltd., fulfils its WEEE obligations by membership of an approved compliance scheme.

**R F Solutions Ltd.,
Unit 21, Cliffe Industrial Estate,
Lewes, E. Sussex. BN8 6JL. England.**

Email : sales@rfsolutions.co.uk <http://www.rfsolutions.co.uk>

Tel Sales: 01273 898 020

Tel Technical: 01273 898 007

Tel Gen Enq: 01273 898 000

Whilst the information in this document is believed to be correct at the time of issue, RF Solutions Ltd does not accept any liability whatsoever for its accuracy, adequacy or completeness. No express or implied warranty or representation is given relating to the information contained in this document. RF Solutions Ltd reserves the right to make changes and improvements to the product(s) described herein without notice. Buyers and other users should determine for themselves the suitability of any such information or products for their own particular requirements or specification(s). RF Solutions Ltd shall not be liable for any loss or damage caused as a result of user's own determination of how to deploy or use RF Solutions Ltd's products. Use of RF Solutions Ltd products or components in life support and/or safety applications is not authorised except with express written approval. No licences are created, implicitly or otherwise, under any of RF Solutions Ltd's intellectual property rights. Liability for loss or damage resulting or caused by reliance on the information contained herein or from the use of the product (including liability resulting from negligence or where RF Solutions Ltd was aware of the possibility of such loss or damage arising) is excluded. This will not operate to limit or restrict RF Solutions Ltd's liability for death or personal injury resulting from its negligence.

