

ANT-DB1-RMS-xxx

Data Sheet

Product Description

Designed for permanent mounting through a metal surface such as an automobile roof or trunk, the compact RMS Series offers excellent performance in a durable and unobtrusive housing. The antenna may be operated at either or both of two frequency bands. It is supplied with 14.1 feet (4.3 m) of RG-58 cable and can be terminated in a standard SMA, Part 15 compliant RP-SMA or a TNC connector.

Features

- Dual-band (824–960MHz and 1.71–1.99GHz)
- Compact & unobtrusive
- Through-hole mount
- Low VSWR
- Excellent performance
- Omni-directional pattern
- Fully weatherized
- Rugged & damage-resistant
- SMA, RP-SMA or TNC connector

Electrical Specifications

Recom. Freq. Range:	Band 1: 824–960MHz Band 2: 1.71–1.99GHz
Wavelength:	¼-wave
VSWR:	Band 1: ≤ 1.5 typ. at center Band 2: ≤ 2.0 typ. at center
Peak Gain:	Band 1: –0.6dBi Band 2: 5.3dBi
Impedance:	50-ohms
Oper. Temp. Range:	–40°C to +80°C
Connector:	SMA, RP-SMA or TNC
Cable:	14.1' (4.3 m) RG-58 coax

Ordering Information

ANT-DB1-RMS-SMA (with SMA connector)
ANT-DB1-RMS-RPS (with RP-SMA connector)
ANT-DB1-RMS-TNC (with TNC connector)

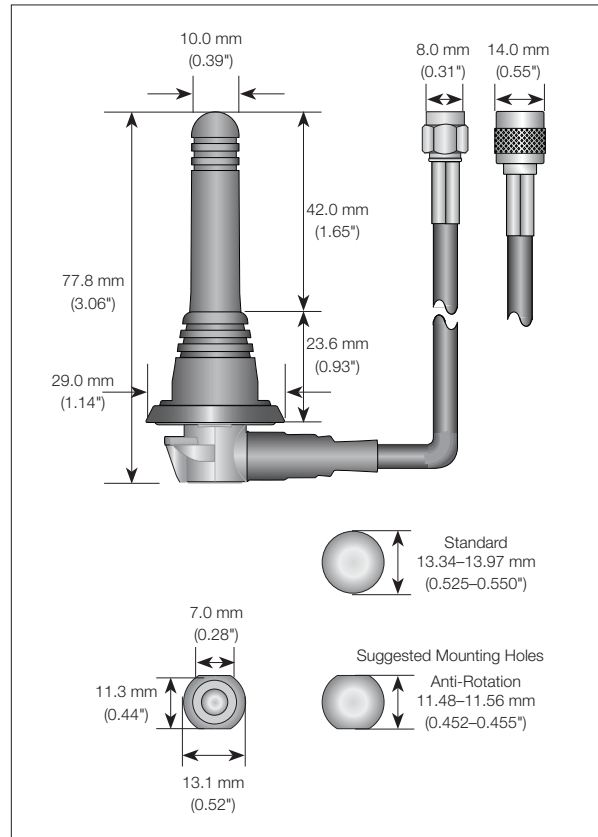

VSWR Graph

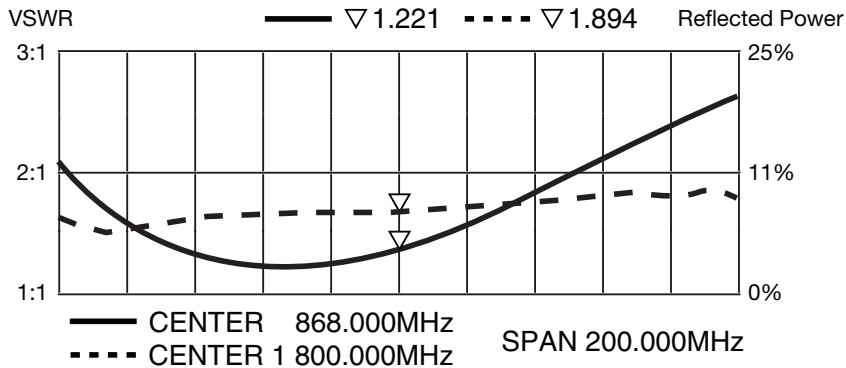

What is VSWR?

The Voltage Standing Wave Ratio (VSWR) is a measurement of how well an antenna is matched to a source impedance, typically 50-ohms. It is calculated by measuring the voltage wave that is headed toward the load versus the voltage wave that is reflected back from the load. A perfect match will have a VSWR of 1:1. The higher the first number, the worse the match, and the more inefficient the system. Since a perfect match cannot ever be obtained, some benchmark for performance needs to be set. In the case of antenna VSWR, this is usually 2:1. At this point, 88.9% of the energy sent to the antenna by the transmitter is radiated into free space and 11.1% is either reflected back into the source or lost as heat on the structure of the antenna. In the other direction, 88.9% of the energy recovered by the antenna is transferred into the receiver. As a side note, since the “:1” is always implied, many data sheets will remove it and just display the first number.

How to Read a VSWR Graph

VSWR is usually displayed graphically versus frequency. The lowest point on the graph is the antenna’s operational center frequency. In most cases, this will be different than the designed center frequency due to fabrication tolerances. The VSWR at that point denotes how close to 50-ohms the antenna gets. Linx specifies the recommended bandwidth as the range where the typical antenna VSWR is less than 2:1.