

FEC-26368-102

SHT 1.1

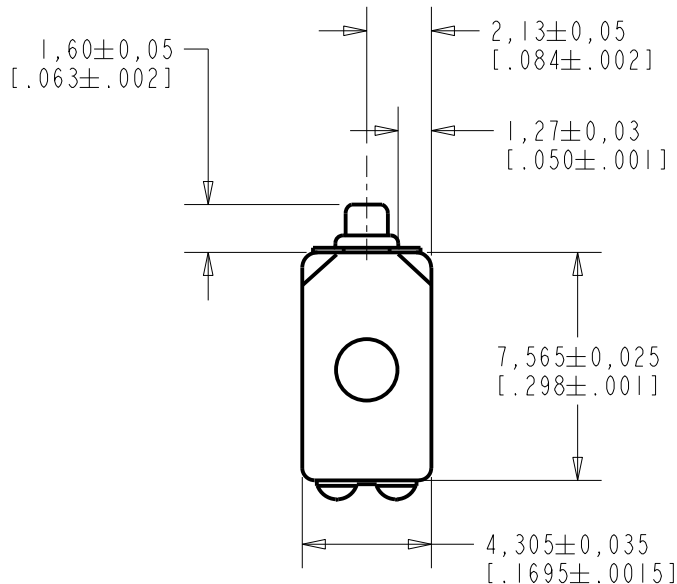

NOTE:

1 A POSITIVE GOING VOLTAGE AT TERMINAL 2, RELATIVE TO TERMINAL 1, CAUSES A DECREASE IN PRESSURE AT THE SOUND OUTLET.

2 LOCATED FROM TWO SURFACES FOR CUSTOMER CONVENIENCE. ONLY APPLICABLE FROM ONE SURFACE, NOT TO BE USED TOGETHER. HORIZONTAL LOCATION FOR TERMINAL CENTERED TO ±0,17 [.007].

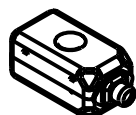
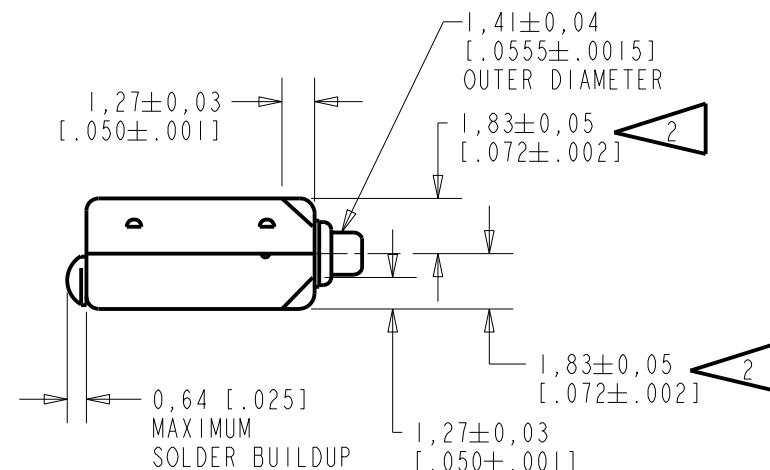
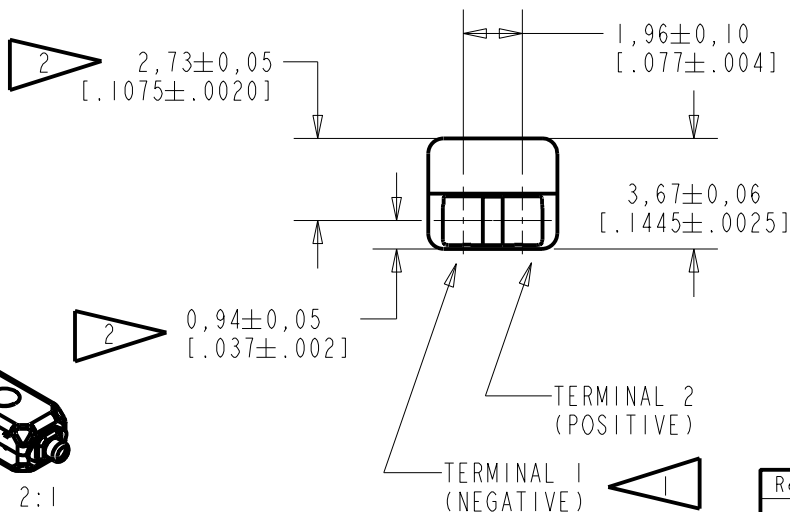

SCALE 2:1
NOMINAL WEIGHT
.42 GRAMS

DIMENSIONS IN MILLIMETERS [INCHES]

Revision	C.O. #	Implementation Date	RELEASE LEVEL	REVISION
B	CI0115009	8-3-13	Active	B
A	CI0103592	1-26-06		

SCALE: 4:1		DR. BY	DATE
DO NOT SCALE DRAWING		AB	1-19-06
TITLE: RECEIVER		CK. BY	DATE
OUTLINE DRAWING		GJP	1-26-06
FEC-26368-102		APP. BY	DATE
SHT 1.1		GJP	1-26-06

KNOWLES ELECTRONICS
ITASCA, ILLINOIS U.S.A.

THE FEC-26368-102 IS A FERROFLUID DAMPED EC. THE AMPLITUDE OF THE PEAK OF THE FREQUENCY RESPONSE IS +2dB RELATIVE TO THE SENSITIVITY AT 1000Hz UNDER CONSTANT VOLTAGE DRIVE CONDITIONS.

FERROFLUID DAMPING

FEC-26368-102

SHEET 2.1

CONSTANT VOLTAGE DRIVE CONDITIONS

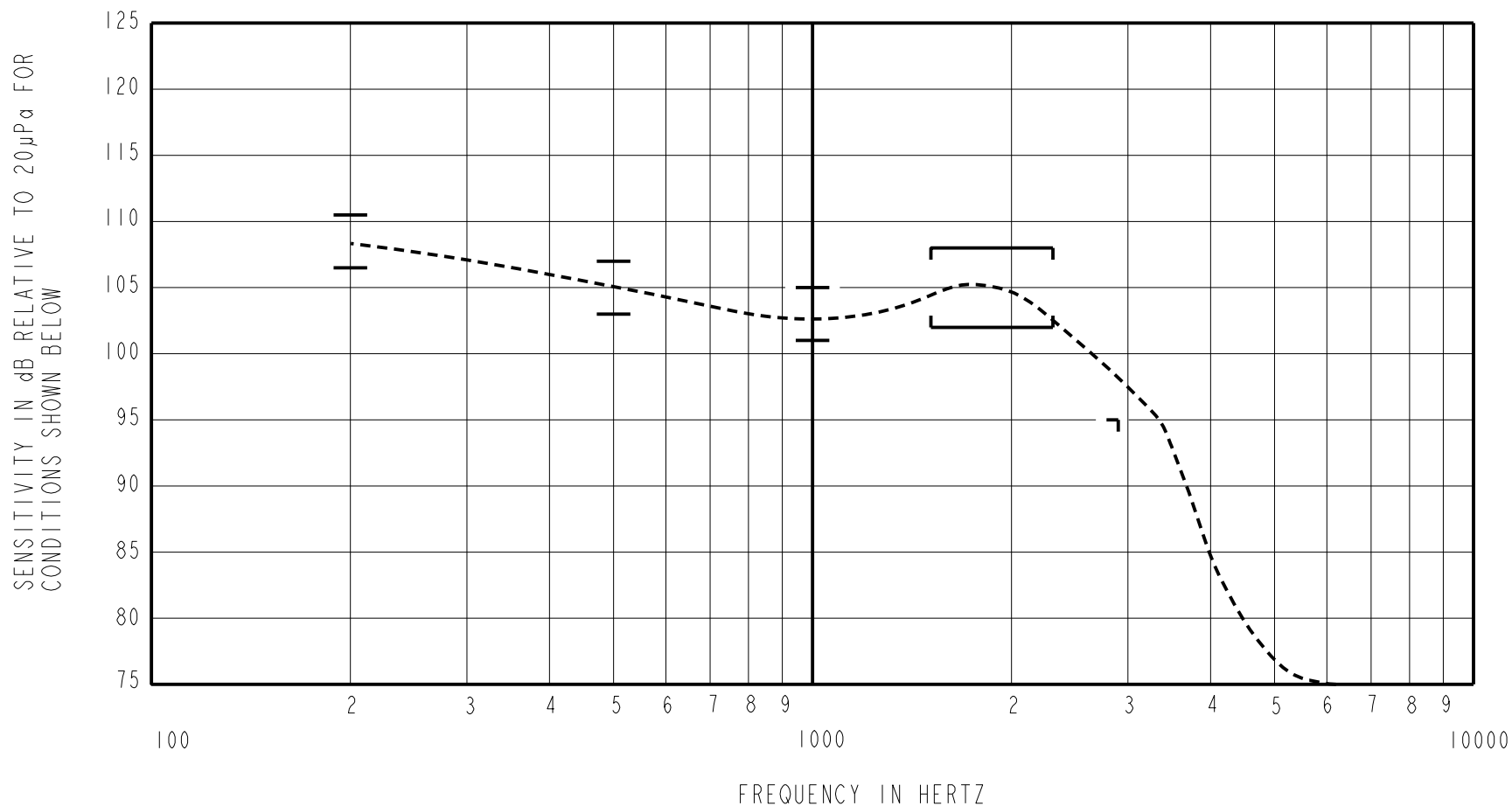

ACOUSTICAL

SENSITIVITY

DEVICE WILL PRODUCE THE SPL LISTED BELOW UNDER TEST CONDITIONS DESCRIBED IN TABLE 3. NOMINAL SENSITIVITY AT 1000 Hz IS dB RELATIVE TO 20µPa. ALL OTHER VALUES IN dB RELATIVE TO THE SENSITIVITY AT 1000 Hz.

FREQUENCY (Hz)	MINIMUM	NOMINAL	MAXIMUM
200	+3.5	+5.5	+7.5
500	+0.0	+2.0	+4.0
1000	-2.0	103.0	+2.0
1510-2310	-1.0	+2.0	+5.0
2900	-8.0	---	---

TABLE 1

TOTAL HARMONIC DISTORTION

DEVICE WILL NOT EXCEED TOTAL HARMONIC DISTORTION LEVELS LISTED BELOW.

FREQUENCY (Hz)	AC DRIVE (V rms)	DC BIAS (mA)	LIMIT (%)
640	0.127	0	6
960	0.127	0	6
960	0.254	0	10

TABLE 2

TEST CONDITIONS

NOMINAL SOURCE VOLTAGE	0.127 V rms, 0mA DC BIAS
SOURCE IMPEDANCE	<1 Ohm
TUBING	10mm [.394"] LONG, 1mm [.039"] I.D.
COUPLER CAVITY	2 CM ³ , SIMULATED ANSI S3.7 TYPE HA-3 (IEC 60318-5)

TABLE 3

ELECTRICAL

DC RESISTANCE	26.3 OHMS ± 10%
IMPEDANCE @ 500 Hz	56 OHMS ± 15%
IMPEDANCE @ 1 kHz	100 OHMS ± 15%

TABLE 4

ISOLATION: CASE WILL BE ELECTRICALLY ISOLATED FROM THE COIL CIRCUIT.

TEMPERATURE: OPERATING RANGE FROM 0°C TO 63°C (SENSITIVITY WILL NOT VARY BY MORE THAN ±3 dB WITHIN RANGE) SENSITIVITY AT 0°C IS 2dB LOWER THAN THE SENSITIVITY AT ROOM TEMPERATURE.

DELTA PEAK IS 1.5dB HIGHER AT BODY TEMPERATURE (37°C)

STORAGE RANGE FROM -40°C TO 63°C.

Revision	C.O. #	Implementation Date	RELEASE LEVEL	REVISION
B	C10115009	8-3-13	Active	B
A	C10103592	1-19-06		

KNOWLES ELECTRONICS
ITASCA, ILLINOIS U.S.A.

WHEN TEST LIMITS ARE USED TO ESTABLISH INCOMING INSPECTION ACCEPTANCE/REJECTION CRITERIA, CORRELATION OF TEST EQUIPMENT WITH KNOWLES IS ALSO REQUIRED FOR ELIMINATION OF EQUIPMENT AND TEST METHOD VARIATION

TITLE: **RECEIVER**
PERFORMANCE SPECIFICATION

FEC-26368-102
SHT 2.1

DR. BY	DATE
AB	1-19-06
CK. BY	DATE
GJP	1-26-06
APP. BY	DATE
GJP	1-26-06