

## PFM Step-Up DC/DC Converter

### RCR2562

#### Features

- Low Start-up Voltage, 1.1V at 1mA
- Minimal Number of External Components ( Only an Inductor, a Diode, a MOSFET and two Capacitors )
- Adjustable version (  $V_{REF} = 1.25V$   $V_{REF} = 2.7V$  or  $V_{REF} = 3.3V$  )
- Ultra Low Input Current (  $12\mu A$  at Switch Off )
- $\pm 2\%$  High Output Voltage Accuracy
- Low Ripple and Low Noise
- 75% Efficiency with Low Cost Inductor

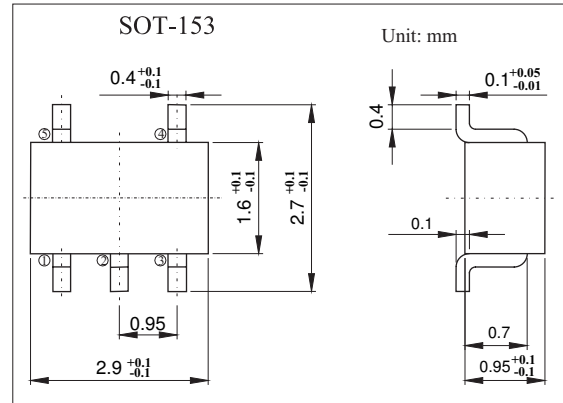

#### Functional Block Diagram

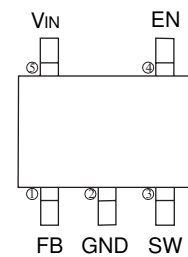
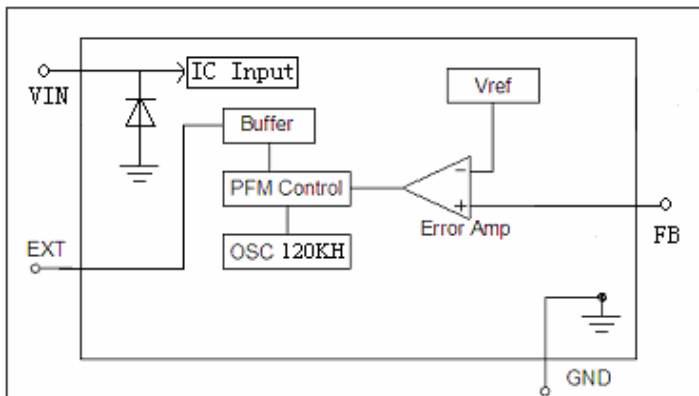

#### Absolute Maximum Ratings $T_a = 25^\circ C$

Parameter	Symbol	Rating	Unit
Output Voltage	$V_{OUT}$	-0.3 to +10	V
EXT Pin Voltage	$V_{EXT}$	-0.3 to +10	V
EXT Pin Current	$I_{EXT}$	$\pm 30$	mA
Power Dissipation @ $T_A = 25^\circ C$	$P_D$	250	mW
Operating Temperature Range	$T_{OPR}$	-40 to +150	$^\circ C$
Storage Temperature Range	$T_{stg}$	-65 to +150	$^\circ C$

## RCR2562

Electrical Characteristics (Ta = 25°C, unless otherwise specified)

Parameter	Symbol	Test conditons	Min	Typ	Max	Unit
Output Voltage Accuracy	$\Delta V_{OUT}$		-2		+2	%
Input Voltage	$V_{IN}$				10	V
FB Pin Voltage	$V_{FB}$	RCR2562 - 125SK	1.22	1.25	1.28	V
		RCR2562 - 270SK	2.65	2.70	2.75	V
		RCR2562 - 330SK	3.24	3.30	3.36	V
Start-up Voltage	$V_{ST}$	$I_{OUT} = 1mA, V_{IN} : 0 \text{ to } 2V$		1.0	1.1	V
Efficiency	EFFI	$V_{OUT} = 3.5V$		75		%
		$V_{OUT} = 3.5V$		85		
Input Current1	$I_{SS}$	$V_{OUT} = 3.5V$	To be measured at $V_{IN}$ at no load	30	40	$\mu A$
		$V_{OUT} = 3.5V$		50	60	
Input Current2	$I_{SWITCHING}$	$V_{OUT} = 3.5V$	To be measured at $V_{OUT}$ in switch off condition	6	12	$\mu A$
		$V_{OUT} = 3.5V$				
Input Current1	$I_{SS}$	$V_{OUT} = 3.5V$	To be measured at $V_{IN}$ at no load	30	40	$\mu A$
		$V_{OUT} = 3.5V$		50	60	
EXT"H"Output Current	$I_{SH}$	$V_{OUT} = 3.5V$	$V_{EXT} = V_{OUT} - 0.4V$	-1.5		mA
		$V_{OUT} = 3.5V$		-2		
EXT"L"Output Current	$I_{SL}$	$V_{OUT} = 3.5V$	$V_{EXT} = 0.4V$	1.5		mA
		$V_{OUT} = 3.5V$		2		
Maximum Oscillator	$F_{MAX}$		80	120	160	KHz
Oscillator Duty Cycle	$D_{OSC}$	On (VLx "L" ) side	70	78	85	%

### Marking

Marking	RCR2562
---------	---------

### Typical Application Circuit ( $V_{OUT} = 5V$ )

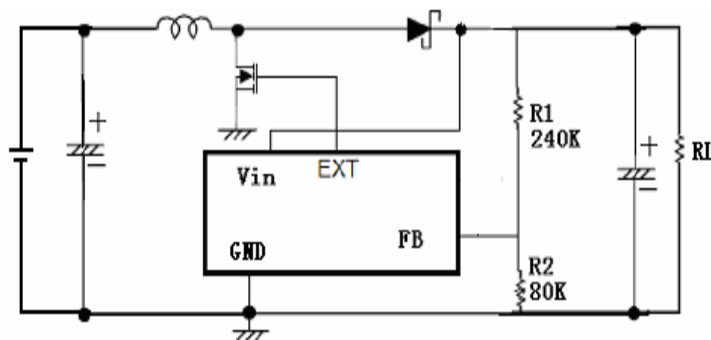

Components :

Inductor : 47uH,

Diode : 1N5818,

Input Capacitor : 1uF/10V ( Tantalum )

Output Capacitor : 47uF/16V ( Tantalum )

## RCR2562

### Typical Application Circuit

1、 RCR2562 ( When  $V_{OUT} = 5V$  ) :

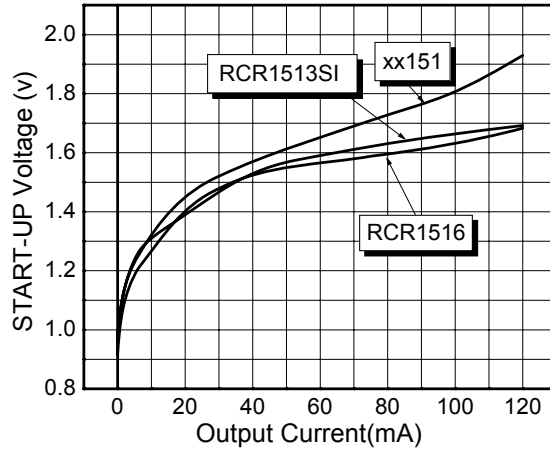

Figure1. Start-up Voltage VS Output Current

2、 RCR2562-125、 RCR2562-27 (  $V_{OUT} = 3.0V$  ) :

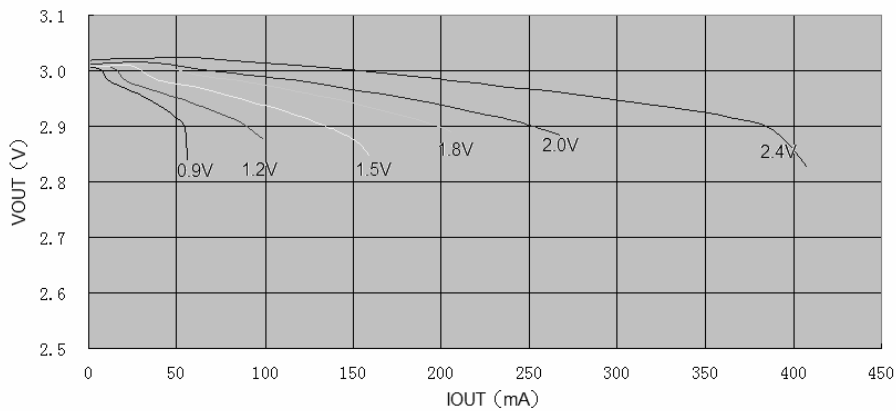

Figure2. Output Voltage VS Output Current

3、 RCR2562 (  $V_{OUT} = 3.3V$  ) :

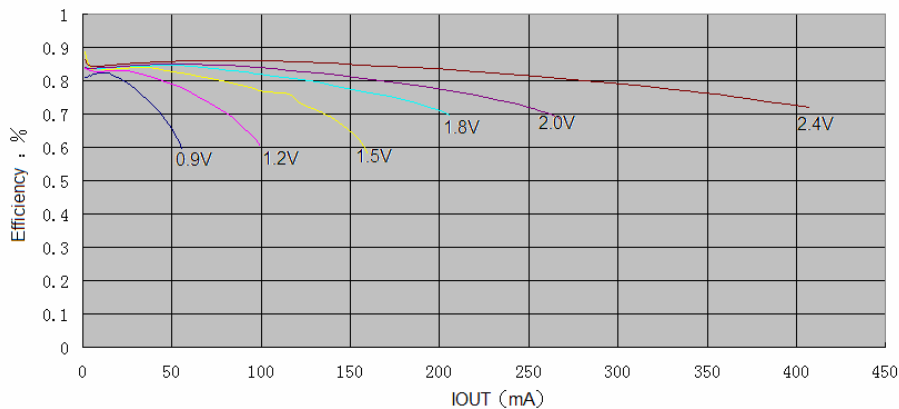

Figure3. Efficiency VS Output current

### RCR2562

Typical Application Circuit

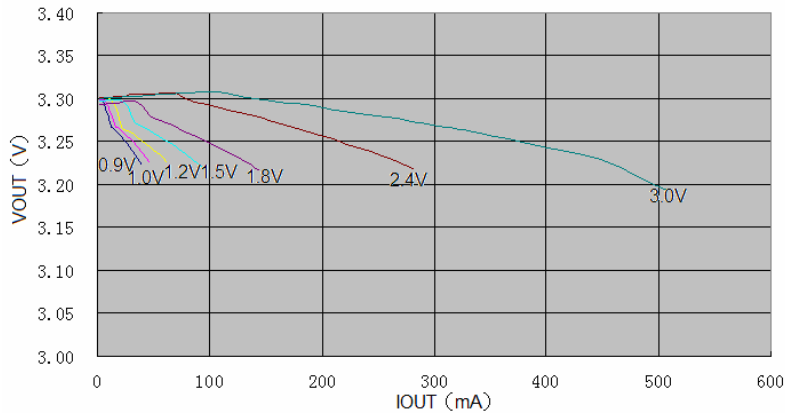

Figure4. Output Voltage VS Output current

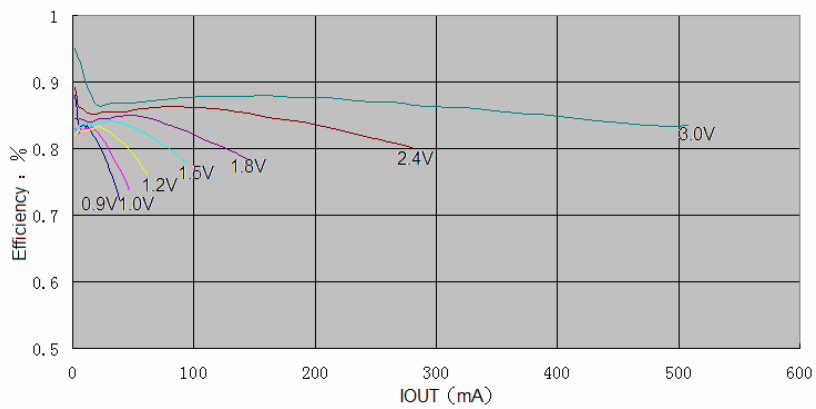

Figure5. Efficiency VS Output current

4、RCR2562 (V<sub>OUT</sub> = 5.0V) :

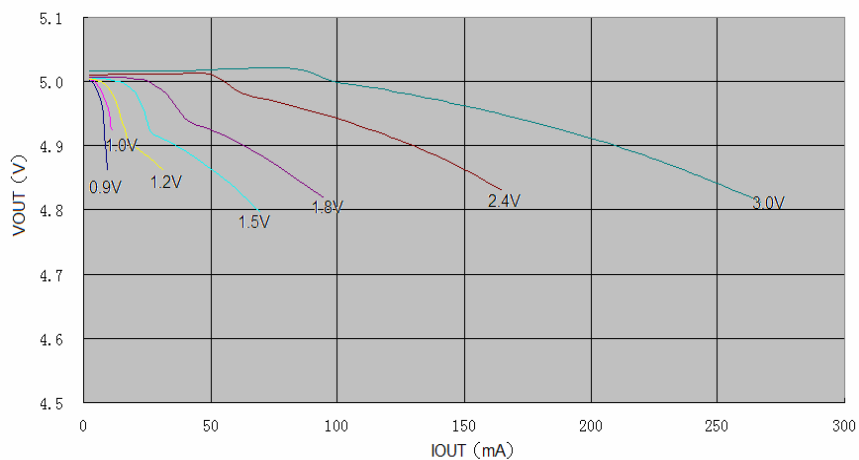

Figure6. Output Voltage VS Output current

## RCR2562

### Typical Application Circuit

#### 5、Efficiency VS. Output Current:

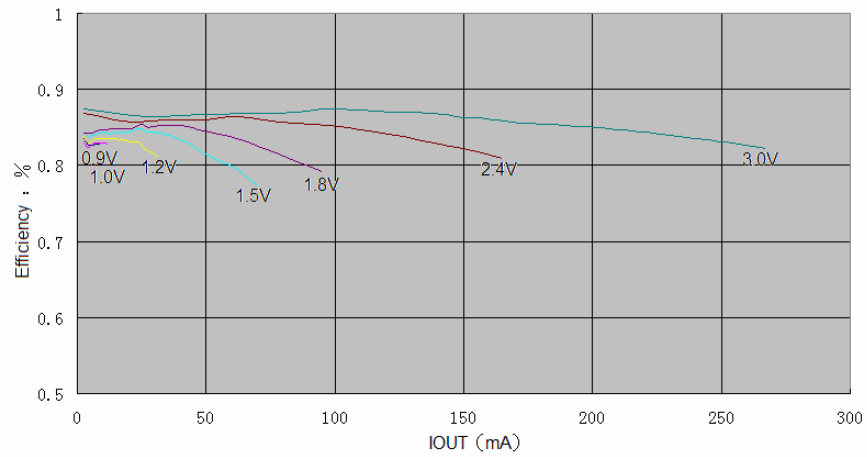

Figure7. Efficiency VS Output current