

## High Isolation Voltage Single Transistor Type Multi Photocoupler Series PS2501-1,-2,-4, PS2501L-1,-2,-4

■ Features

- High isolation voltage ( $B_v = 5\,000\text{ Vr.m.s.}$ )
- High collector to emitter voltage ( $V_{CE0} = 80\text{ V}$ )
- High-speed switching ( $t_r = 3\ \mu\text{s TYP.}$ ,  $t_f = 5\ \mu\text{s TYP.}$ )

■ Package Dimensions (In millimeters)

DIP Type

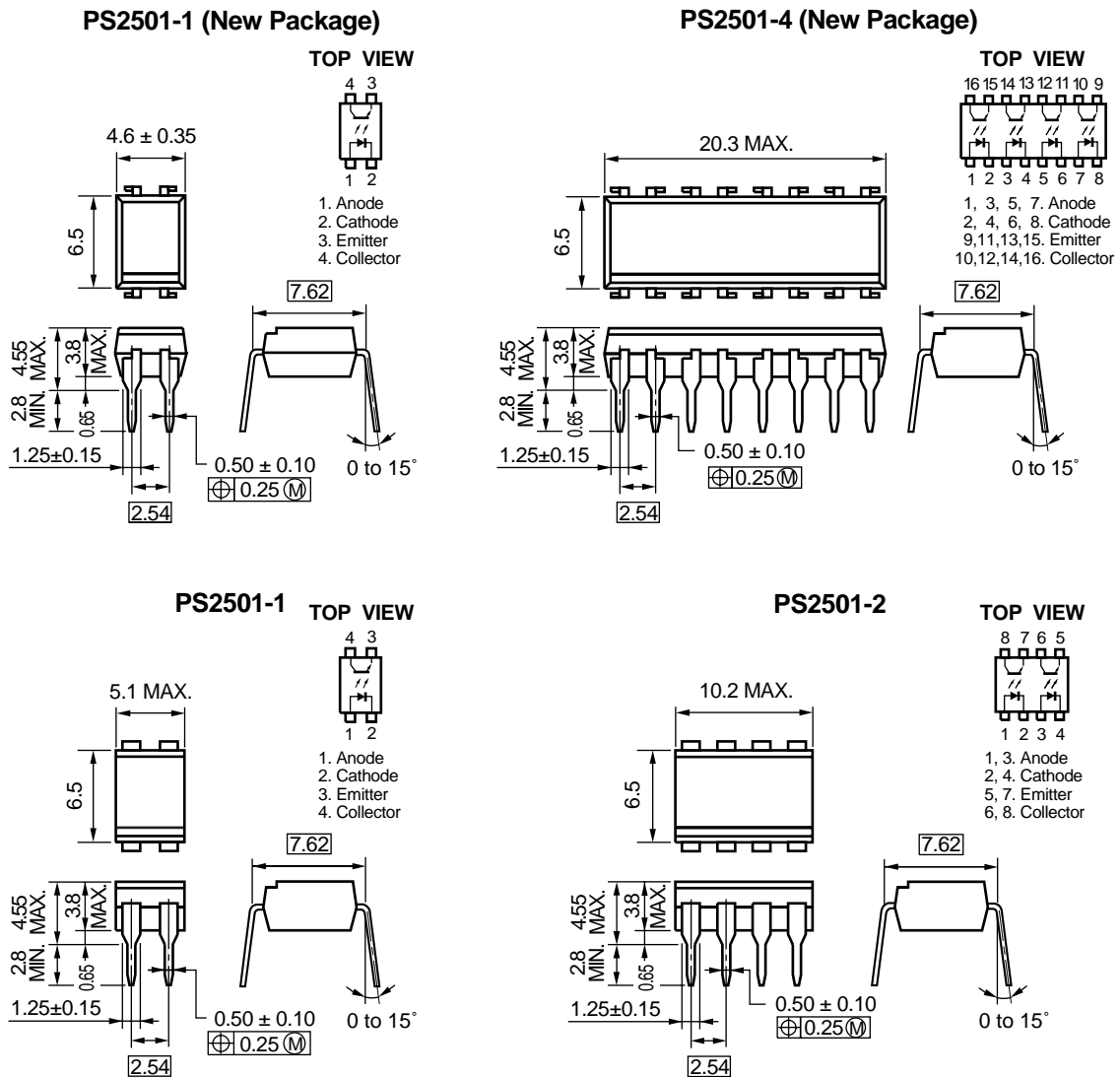

PS2501-1,-2,-4, PS2501L-1,-2,-4

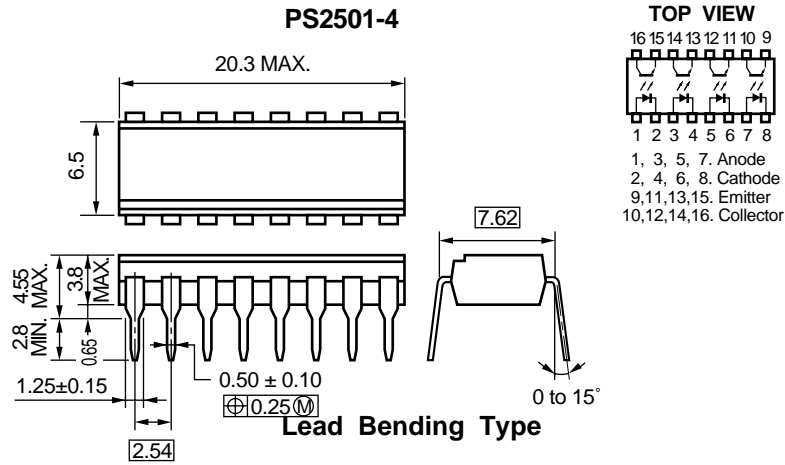

Lead Bending Type

PS2501L-1 (New Package)

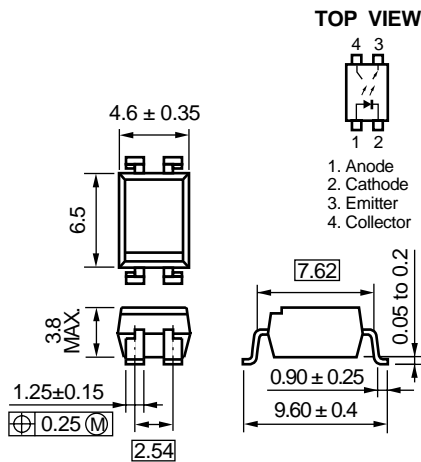

PS2501L-4 (New Package)

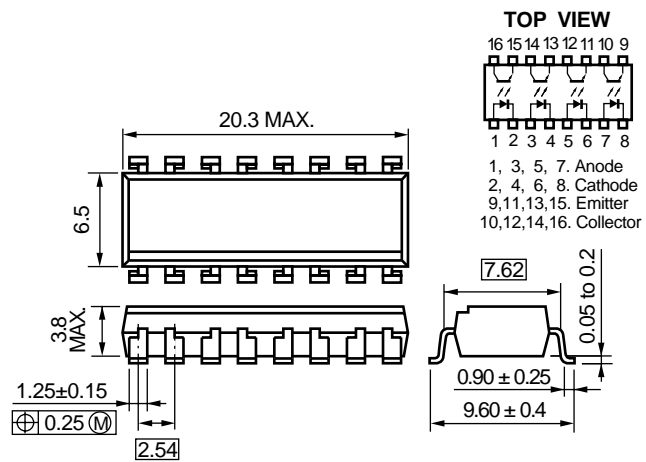

PS2501L-1

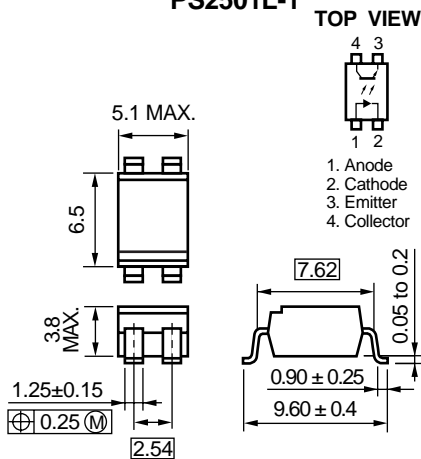

PS2501L-2

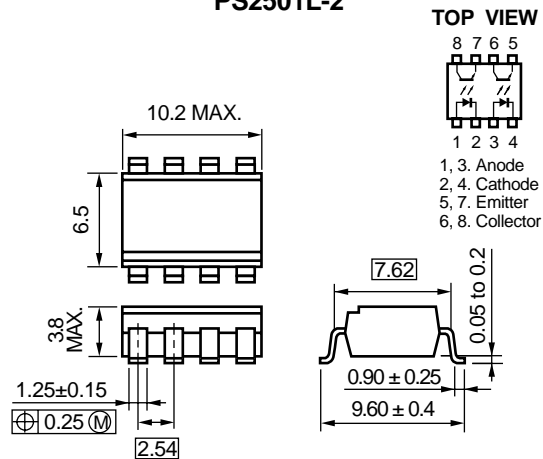

## PS2501-1,-2,-4, PS2501L-1,-2,-4

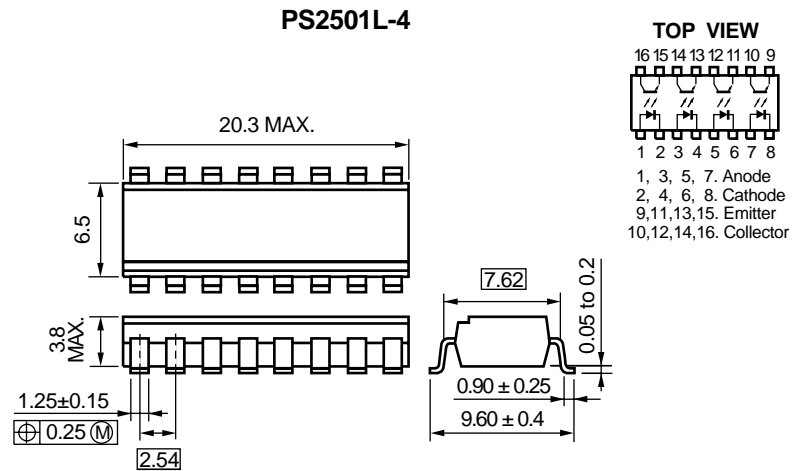
■ Absolute Maximum Ratings  $T_a = 25^\circ\text{C}$ 

Parameter		Symbol	Ratings		Unit
			PS2501-1, PS2501L-1	PS2501-2,-4 PS2501L-2,-4	
Diode	Reverse Voltage	$V_R$	6		V
	Forward Current (DC)	$I_F$	80		mA
	Power Dissipation Derating	$\Delta P_D/^\circ\text{C}$	1.5	1.2	mW/°C
	Power Dissipation	$P_D$	150	120	mW/ch
	Peak Forward Current <sup>*1</sup>	$I_{FP}$	1		A
Transistor	Collector to Emitter Voltage	$V_{CEO}$	80		V
	Emitter to Collector Voltage	$V_{ECO}$	7		V
	Collector Current	$I_C$	50		mA/ch
	Power Dissipation Derating	$\Delta P_C/^\circ\text{C}$	1.5	1.2	mW/°C
	Power Dissipation	$P_C$	150	120	mW/ch
Isolation Voltage <sup>*2</sup>		BV	5 000		Vr.m.s.
Operating Ambient Temperature		$T_A$	-55 to +100		°C
Storage Temperature		$T_{stg}$	-55 to +150		°C

\*1  $PW = 100 \mu\text{s}$ , Duty Cycle = 1 %

\*2 AC voltage for 1 minute at  $T_A = 25^\circ\text{C}$ , RH = 60 % between input and output

## PS2501-1,-2,-4, PS2501L-1,-2,-4

## ■ Electrical Characteristics(TA=25 °C, unless otherwise specified)

Parameter		Symbol	Conditions	MIN.	TYP.	MAX.	Unit
Diode	Forward VoltageV	$V_F$	$I_F = 10 \text{ mA}$		1.17	1.4	V
	Reverse Current	$I_R$	$V_R = 5 \text{ V}$			5	$\mu\text{A}$
	Terminal Capacitance	$C_t$	$V = 0 \text{ V}, f = 1.0 \text{ MHz}$		50		pF
Transistor	Collector to Emitter Dark Current	$I_{CEO}$	$V_{CE} = 80 \text{ V}, I_F = 0 \text{ mA}$			100	nA
Coupled	Current Transfer Ratio ( $I_C/I_F$ ) <sup>*1</sup>	CTR	$I_F = 5 \text{ mA}, V_{CE} = 5 \text{ V}$	80	300	600	%
	Collector Saturation Voltage	$V_{CE(sat)}$	$I_F = 10 \text{ mA}, I_C = 2 \text{ mA}$			0.3	V
	Isolation Resistance	$R_{I-O}$	$V_{I-O} = 1.0 \text{ kV}_{DC}$	$10^{11}$			$\Omega$
	Isolation Capacitance	$C_{I-O}$	$V = 0 \text{ V}, f = 1.0 \text{ MHz}$		0.5		pF
	Rise Time <sup>*2</sup>	$t_r$	$V_{CC} = 10 \text{ V}, I_C = 2 \text{ mA}, R_L = 100 \Omega$		3		$\mu\text{s}$
	Fall Time <sup>*2</sup>	$t_f$			5		

\*1 CTR rank (\* : only PS2501-1, PS2501L-1)

\*2 Test circuit for switching time

K\* : 300 to 600 (%)  
 L\* : 200 to 400 (%)  
 M\* : 80 to 240 (%)  
 D\* : 100 to 300 (%)  
 H\* : 80 to 160 (%)  
 W\* : 130 to 260 (%)  
 Q\* : 100 to 200 (%)  
 N : 80 to 600 (%)

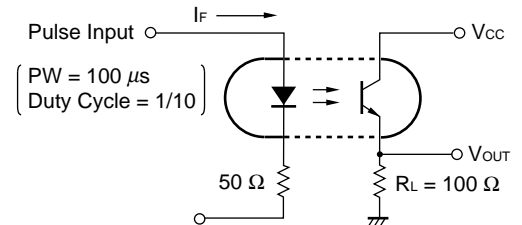

**PS2501-1,-2,-4, PS2501L-1,-2,-4**

■ Typical Characteristics (TA=25°C, unless otherwise specified)

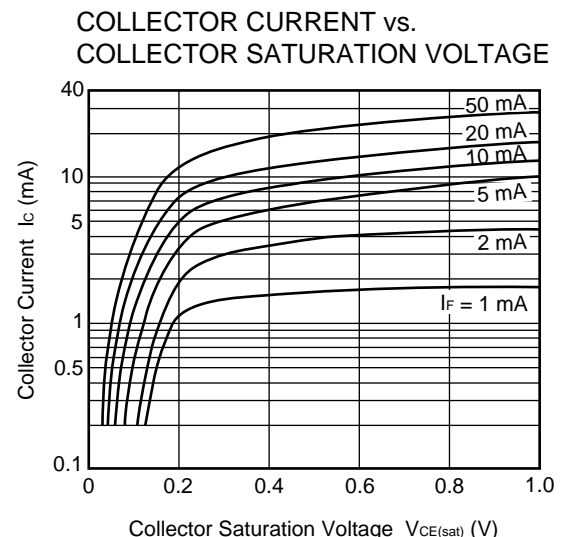
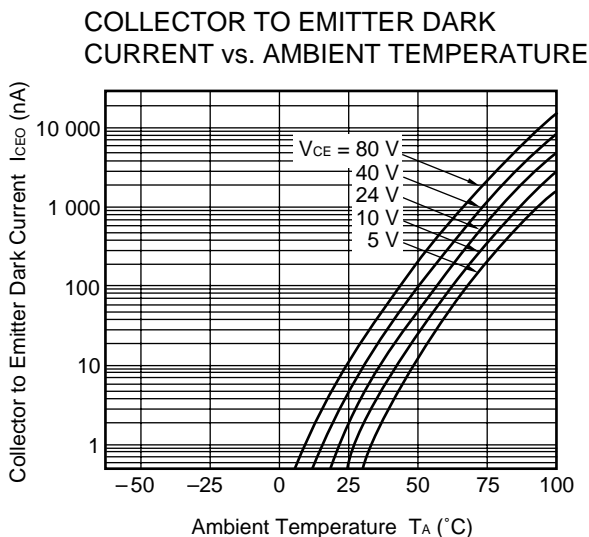
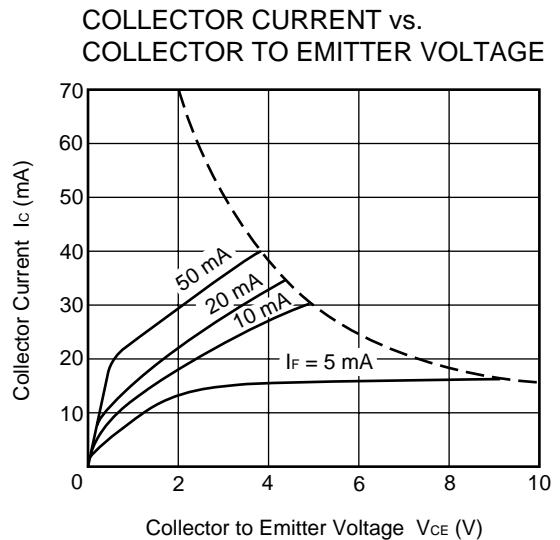
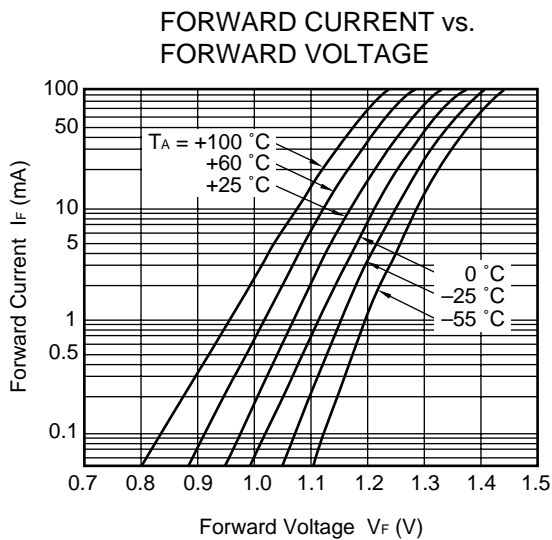
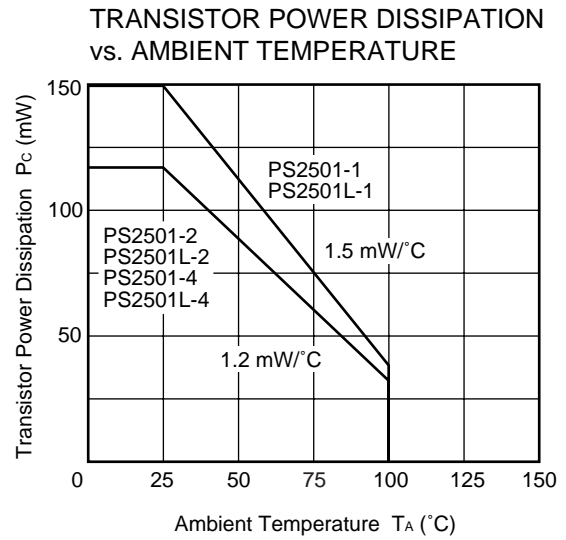
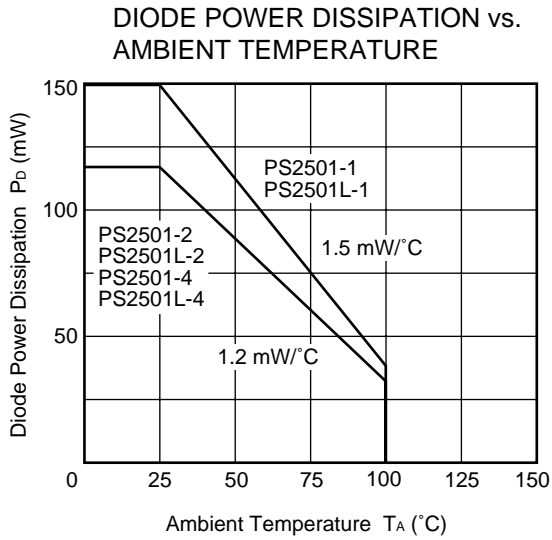

PS2501-1,-2,-4, PS2501L-1,-2,-4

NORMALIZED CURRENT TRANSFER RATIO vs. AMBIENT TEMPERATURE

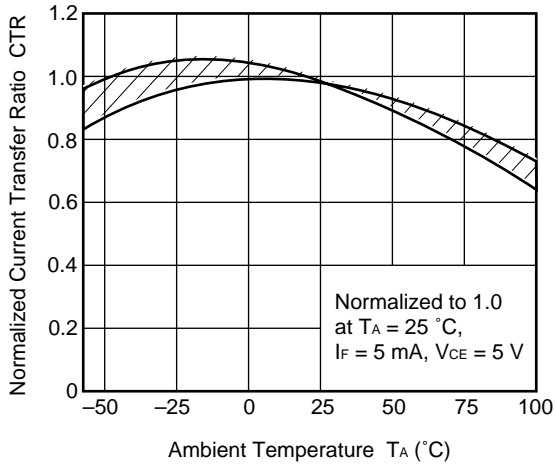

CURRENT TRANSFER RATIO vs. FORWARD CURRENT

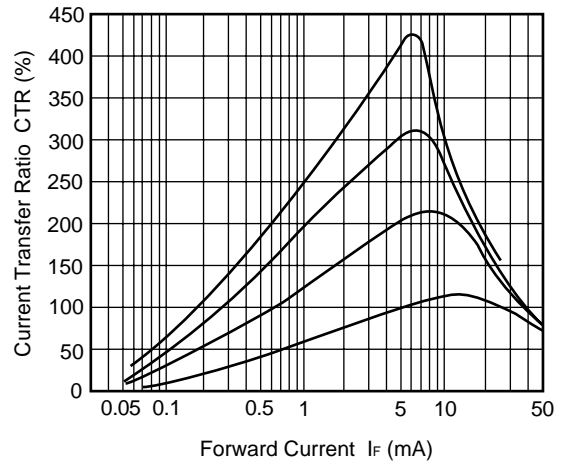

SWITCHING TIME vs. LOAD RESISTANCE

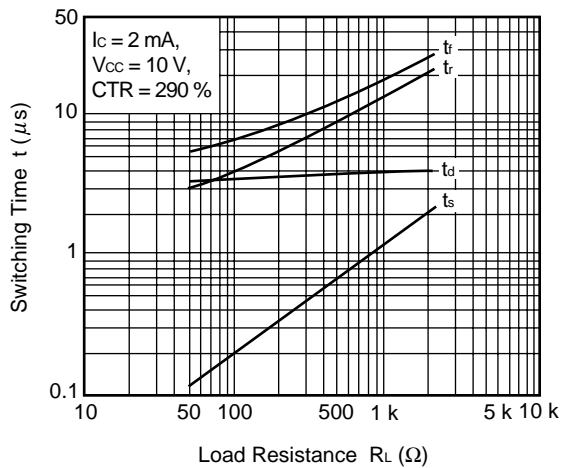

SWITCHING TIME vs. LOAD RESISTANCE

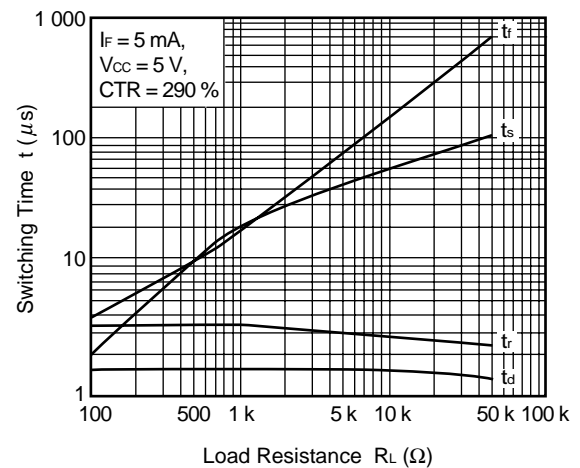

FREQUENCY RESPONSE

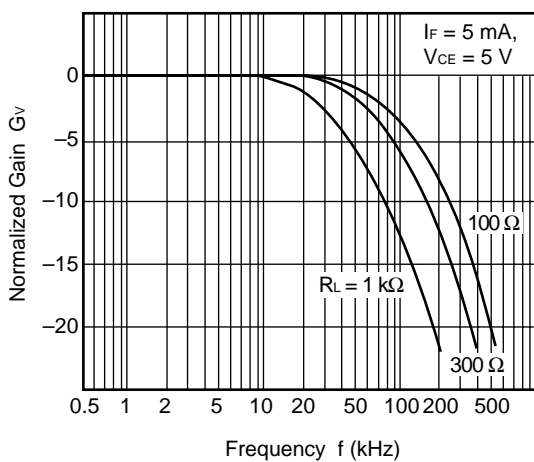

LONG TERM CTR DEGRADATION

