

High Isolation Voltage Single Transistor Type Multi Photocoupler Series PS2501-1,-2,-4, PS2501L-1,-2,-4

■ Features

- High isolation voltage ($B_v = 5\,000\text{ Vr.m.s.}$)
- High collector to emitter voltage ($V_{CE0} = 80\text{ V}$)
- High-speed switching ($t_r = 3\ \mu\text{s TYP.}$, $t_f = 5\ \mu\text{s TYP.}$)

■ Package Dimensions (In millimeters)

DIP Type

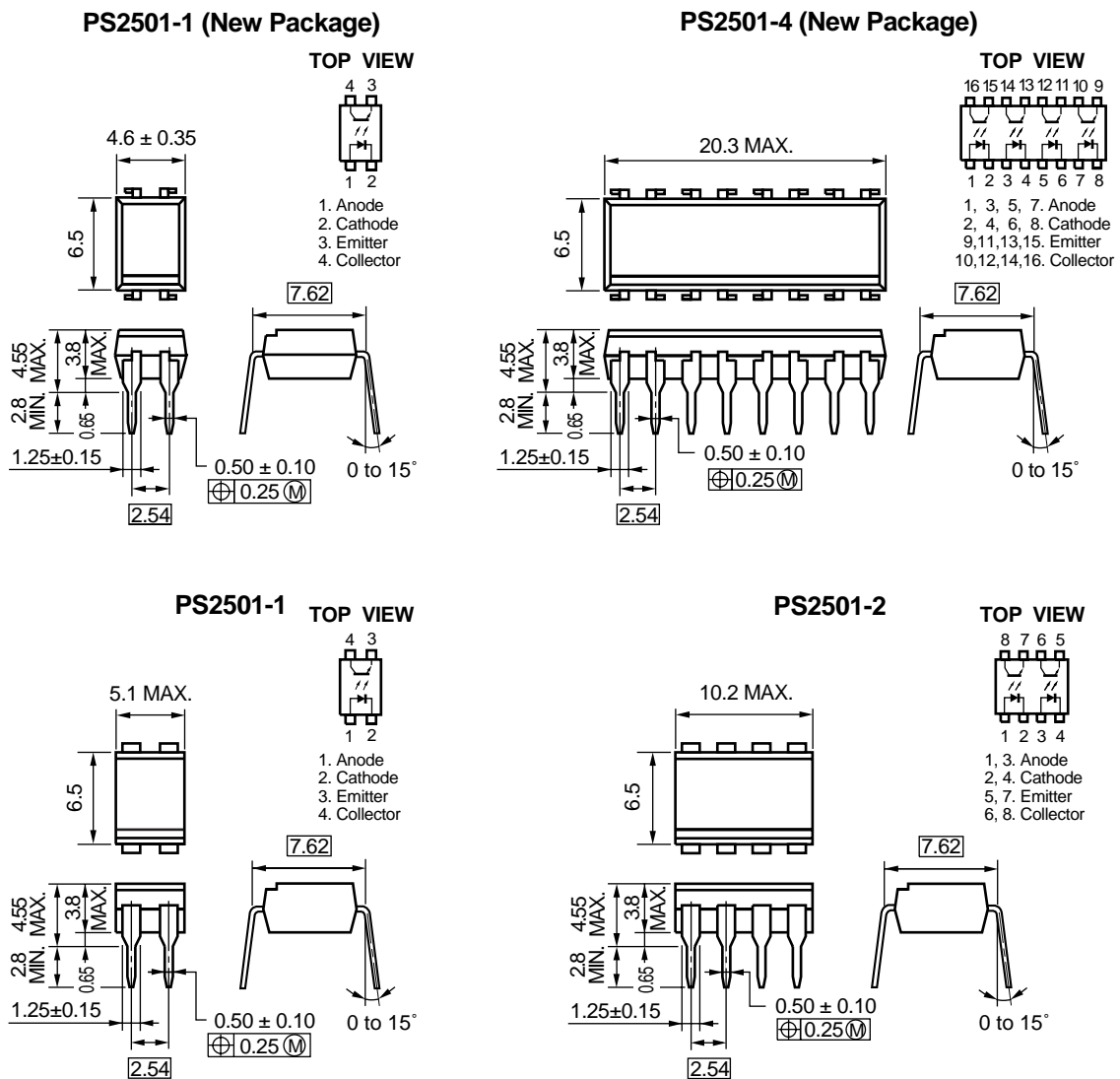

PS2501-1,-2,-4, PS2501L-1,-2,-4

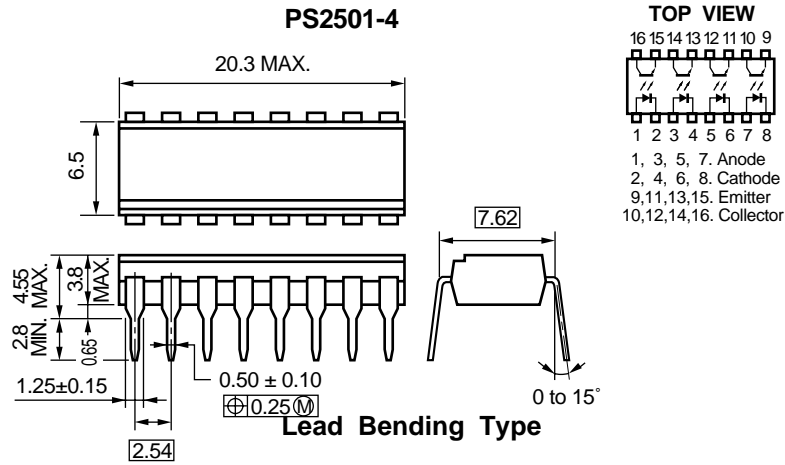

Lead Bending Type

PS2501L-1 (New Package)

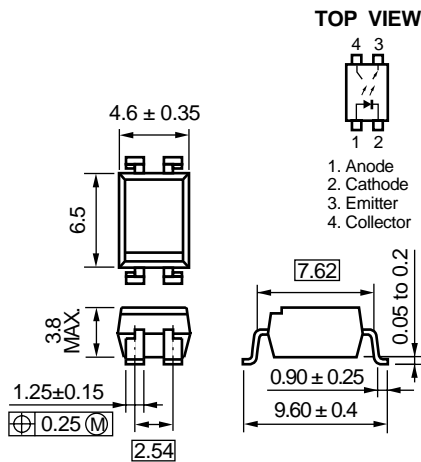

PS2501L-4 (New Package)

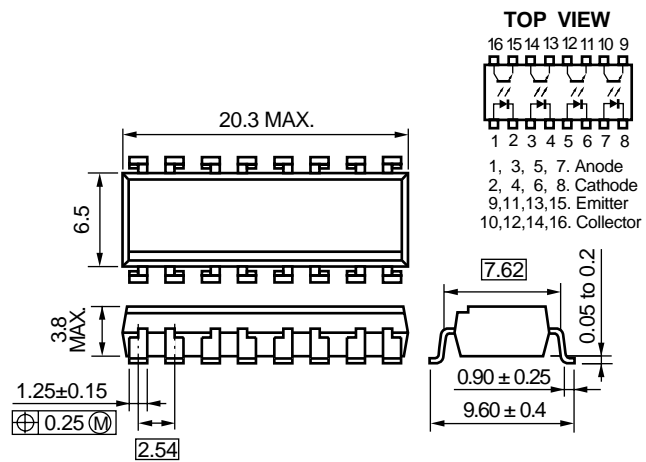

PS2501L-1

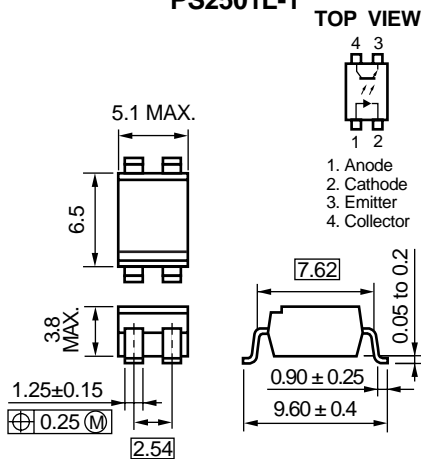

PS2501L-2

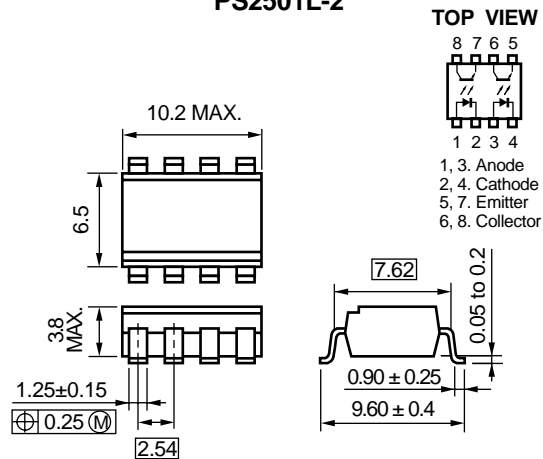

PS2501-1,-2,-4, PS2501L-1,-2,-4

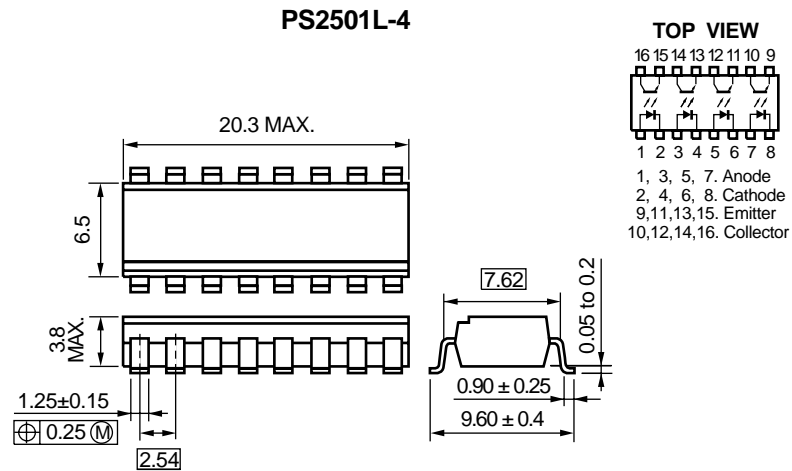
■ Absolute Maximum Ratings $T_a = 25^\circ\text{C}$

Parameter	Symbol	Ratings		Unit	
		PS2501-1, PS2501L-1	PS2501-2,-4 PS2501L-2,-4		
Diode	Reverse Voltage	V_R	6		V
	Forward Current (DC)	I_F	80		mA
	Power Dissipation Derating	$\Delta P_D/^\circ\text{C}$	1.5	1.2	mW/°C
	Power Dissipation	P_D	150	120	mW/ch
	Peak Forward Current ^{*1}	I_{FP}	1		A
Transistor	Collector to Emitter Voltage	V_{CEO}	80		V
	Emitter to Collector Voltage	V_{ECO}	7		V
	Collector Current	I_C	50		mA/ch
	Power Dissipation Derating	$\Delta P_C/^\circ\text{C}$	1.5	1.2	mW/°C
	Power Dissipation	P_C	150	120	mW/ch
Isolation Voltage ^{*2}	BV	5 000		Vr.m.s.	
Operating Ambient Temperature	T_A	-55 to +100		°C	
Storage Temperature	T_{stg}	-55 to +150		°C	

*1 $PW = 100 \mu\text{s}$, Duty Cycle = 1 %

*2 AC voltage for 1 minute at $T_A = 25^\circ\text{C}$, RH = 60 % between input and output

PS2501-1,-2,-4, PS2501L-1,-2,-4

■ Electrical Characteristics(TA=25 °C, unless otherwise specified)

Parameter		Symbol	Conditions	MIN.	TYP.	MAX.	Unit
Diode	Forward VoltageV	V_F	$I_F = 10 \text{ mA}$		1.17	1.4	V
	Reverse Current	I_R	$V_R = 5 \text{ V}$			5	μA
	Terminal Capacitance	C_t	$V = 0 \text{ V}, f = 1.0 \text{ MHz}$		50		pF
Transistor	Collector to Emitter Dark Current	I_{CEO}	$V_{CE} = 80 \text{ V}, I_F = 0 \text{ mA}$			100	nA
Coupled	Current Transfer Ratio (I_C/I_F) ^{*1}	CTR	$I_F = 5 \text{ mA}, V_{CE} = 5 \text{ V}$	80	300	600	%
	Collector Saturation Voltage	$V_{CE(sat)}$	$I_F = 10 \text{ mA}, I_C = 2 \text{ mA}$			0.3	V
	Isolation Resistance	R_{I-O}	$V_{I-O} = 1.0 \text{ kV}_{DC}$	10^{11}			Ω
	Isolation Capacitance	C_{I-O}	$V = 0 \text{ V}, f = 1.0 \text{ MHz}$		0.5		pF
	Rise Time ^{*2}	t_r	$V_{CC} = 10 \text{ V}, I_C = 2 \text{ mA}, R_L = 100 \Omega$		3		μs
	Fall Time ^{*2}	t_f			5		

1 CTR rank (: only PS2501-1, PS2501L-1)

*2 Test circuit for switching time

K* : 300 to 600 (%)
 L* : 200 to 400 (%)
 M* : 80 to 240 (%)
 D* : 100 to 300 (%)
 H* : 80 to 160 (%)
 W* : 130 to 260 (%)
 Q* : 100 to 200 (%)
 N : 80 to 600 (%)

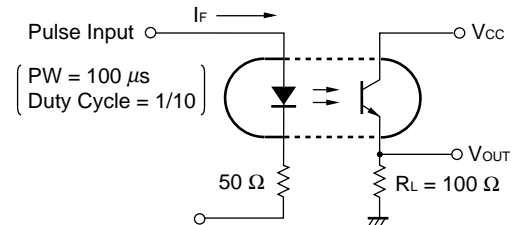

PS2501-1,-2,-4, PS2501L-1,-2,-4

■ Typical Characteristics (TA=25°C, unless otherwise specified)

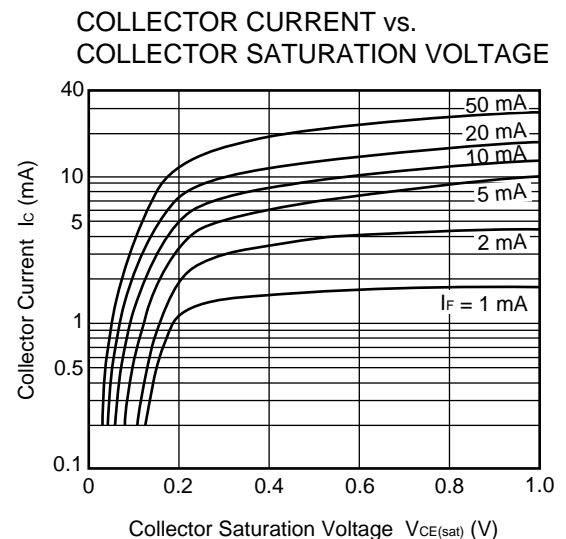
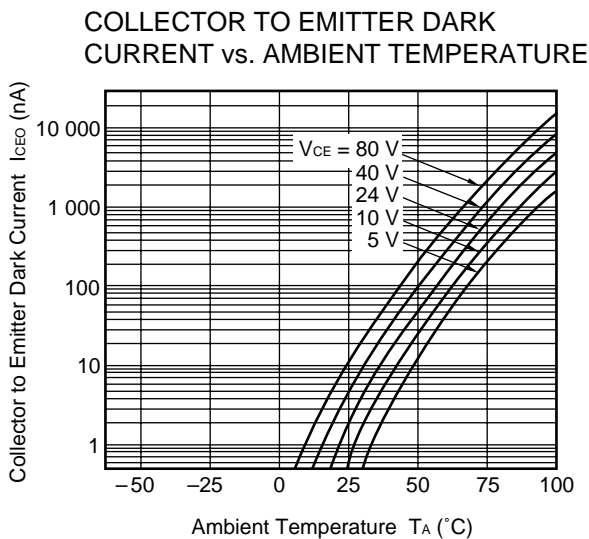
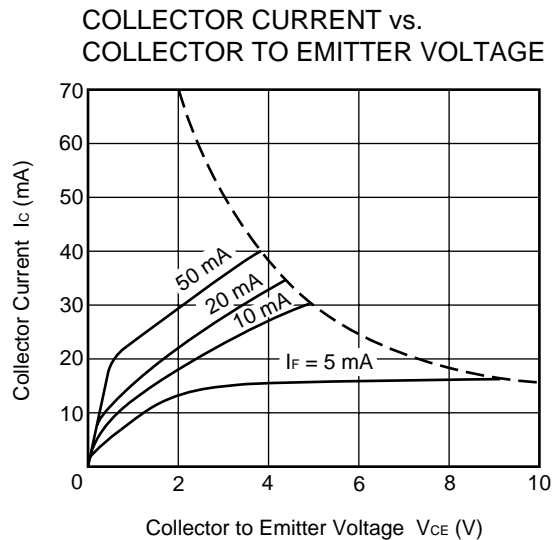
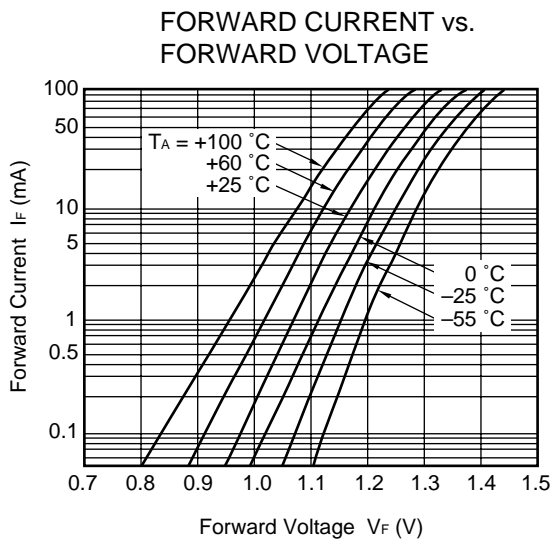
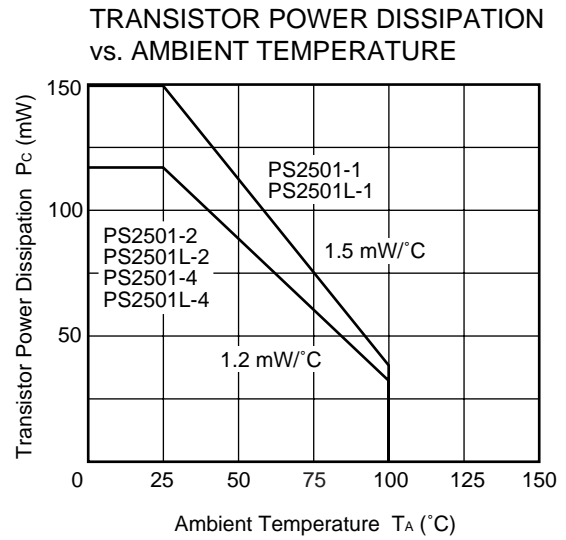
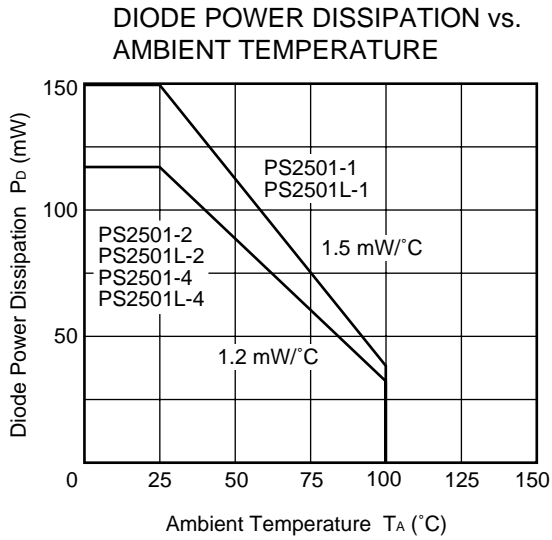

PS2501-1,-2,-4, PS2501L-1,-2,-4

NORMALIZED CURRENT TRANSFER RATIO vs. AMBIENT TEMPERATURE

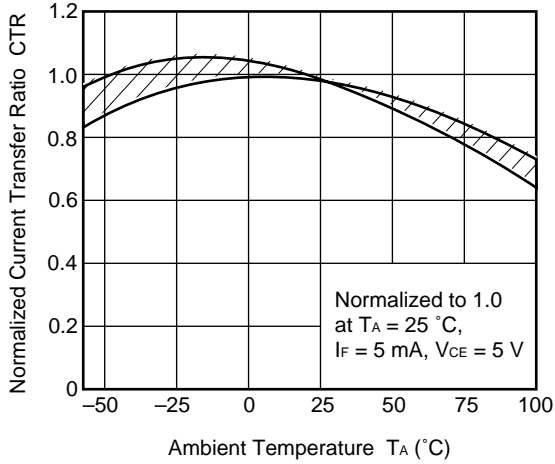

CURRENT TRANSFER RATIO vs. FORWARD CURRENT

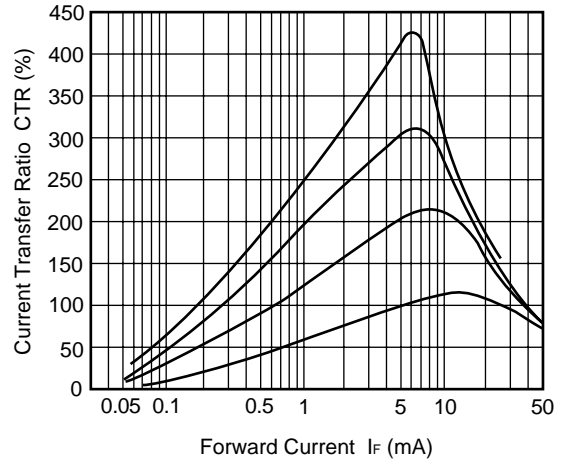

SWITCHING TIME vs. LOAD RESISTANCE

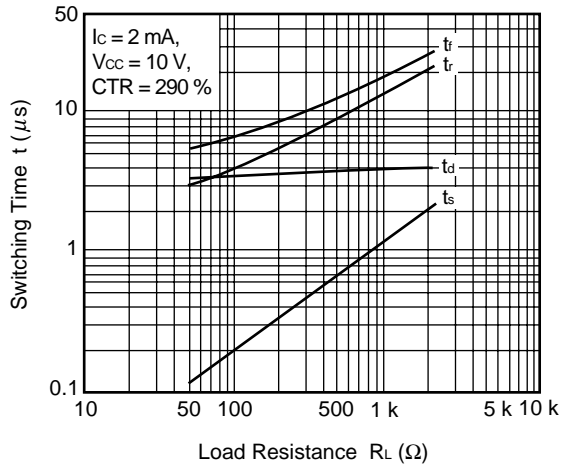

SWITCHING TIME vs. LOAD RESISTANCE

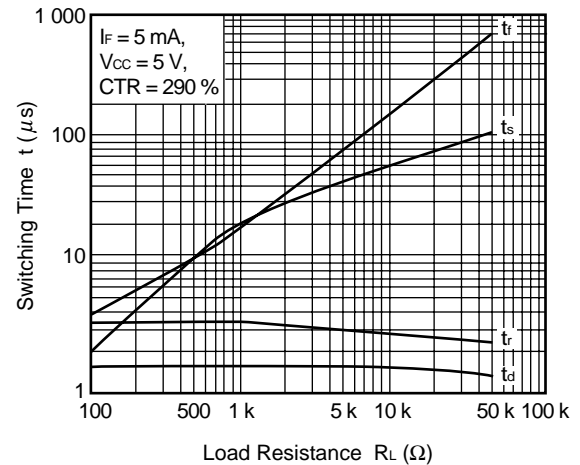

FREQUENCY RESPONSE

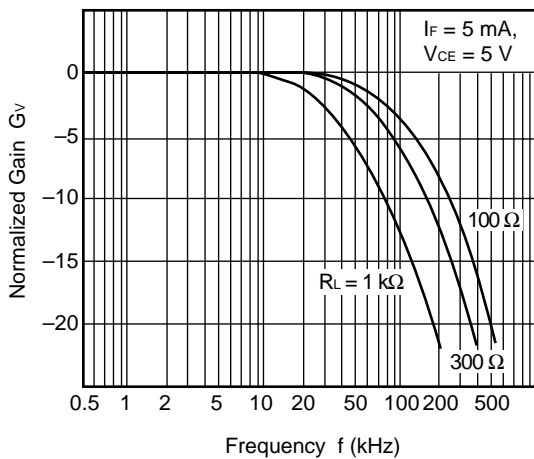

LONG TERM CTR DEGRADATION

