

2A, 18V Synchronous Rectified Step-Down Converter

MP1482

Features

- 2A Output Current
- Wide 4.75V to 18V Operating Input Range
- Integrated 130mΩ Power MOSFET Switches
- Output Adjustable from 0.923V to 15V
- Up to 93% Efficiency
- Programmable Soft-Start
- Stable with Low ESR Ceramic Output Capacitors
- Fixed 340KHz Frequency
- Cycle-by-Cycle Over Current Protection
- Input Under Voltage Lockout

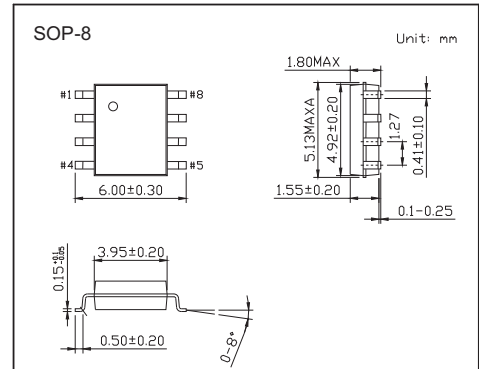

Functional Block Diagram

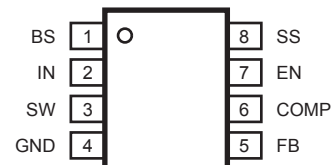
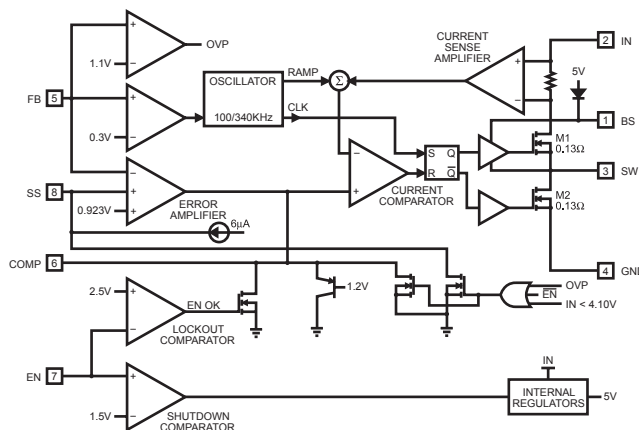

Absolute Maximum Ratings $T_a = 25^\circ\text{C}$

Parameter	Symbol	Rating	Unit
Input Voltage	V_{in}	-0.3 to 20	V
Switch Voltage	V_{sw}	21	V
Boot Strap Voltage	V_{bs}	$V_{sw}-0.3V$ to $V_{sw}+6$	V
All Other Pins		-0.3 to 6V	V
Power Dissipation	P_D	1300	mW
Thermal Resistance	$R_{\theta JA}$	90	$^\circ\text{C}/\text{W}$
Junction Temperature	T_j	150	$^\circ\text{C}$
Storage Temperature	T_{stg}	-65 to 150	$^\circ\text{C}$
Lead Temperature	T_L	260	$^\circ\text{C}$

Recommended Operating Conditions

Input Voltage	V_{in}	4.75 to 18	V
Output Voltage	V_{out}	0.923 to 15	V
Operating Temperature	T_A	-40 to 85	$^\circ\text{C}$

MP1482

Electrical Characteristics (Ta = 25°C, VIN=12V, unless otherwise specified)

Parameter	Symbol	Condition	Min	Typ	Max	Units
Shutdown Supply Current		$V_{EN} = 0V$		1	3.0	μA
Supply Current		$V_{EN} = 2.0V; V_{FB} = 1.0V$		1.3	1.5	mA
Feedback Voltage	V_{FB}	$4.75V \leq V_{IN} \leq 18V$	0.900	0.923	0.946	V
Feedback Overvoltage Threshold				1.1		V
Error Amplifier Voltage Gain ⁽⁴⁾	A_{EA}			400		V/V
Error Amplifier Transconductance	G_{EA}	$\Delta I_C = \pm 10\mu A$		800		$\mu A/V$
High-Side Switch On Resistance ⁽⁴⁾	$R_{DS(ON)1}$			130		m Ω
Low-Side Switch On Resistance ⁽⁴⁾	$R_{DS(ON)2}$			130		m Ω
High-Side Switch Leakage Current		$V_{EN} = 0V, V_{SW} = 0V$			10	μA
Upper Switch Current Limit		Minimum Duty Cycle	2.4	3.4		A
Lower Switch Current Limit		From Drain to Source		1.1		A
COMP to Current Sense Transconductance	G_{CS}			3.5		A/V
Oscillation Frequency	F_{osc1}			340		KHz
Short Circuit Oscillation Frequency	F_{osc2}	$V_{FB} = 0V$		100		KHz
Maximum Duty Cycle	D_{MAX}	$V_{FB} = 1.0V$		90		%
Minimum On Time ⁽⁴⁾				220		ns
EN Shutdown Threshold Voltage		V_{EN} Rising	1.1	1.5	2.0	V
EN Shutdown Threshold Voltage Hysteresis				210		mV
EN Lockout Threshold Voltage			2.2	2.5	2.7	V
EN Lockout Hysteresis				210		mV
Input Under Voltage Lockout Threshold		V_{IN} Rising	3.80	4.10	4.40	V
Input Under Voltage Lockout Threshold Hysteresis				210		mV
Soft-Start Current		$V_{SS} = 0V$		6		μA
Soft-Start Period		$C_{SS} = 0.1\mu F$		15		ms
Thermal Shutdown ⁽¹⁾				160		$^{\circ}C$

Note:

1) Guaranteed by design, not tested.

Typical Characteristics

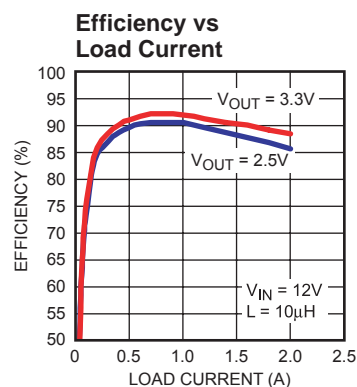
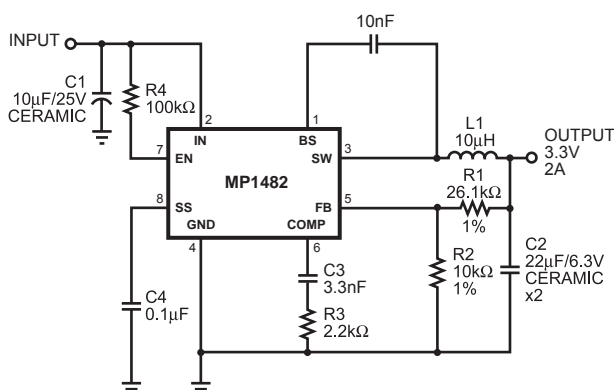

MP1482

Typical Characteristics

Steady State Test

$V_{IN} = 12V$, $V_{OUT} = 3.3V$
 $I_{OUT} = 0A$, $I_{IN} = 8.2mA$

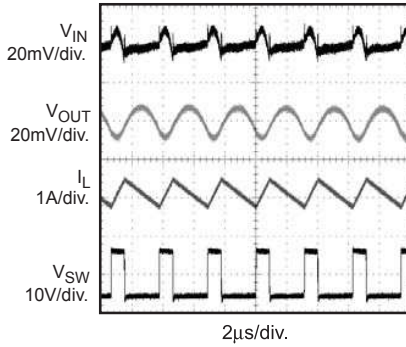

Startup through Enable

$V_{IN} = 12V$, $V_{OUT} = 3.3V$
 $I_{OUT} = 1A$ (Resistance Load)

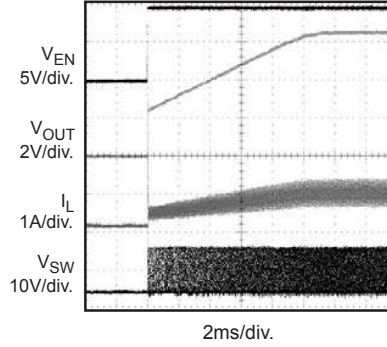

Shutdown through Enable

$V_{IN} = 12V$, $V_{OUT} = 3.3V$
 $I_{OUT} = 1A$ (Resistance Load)

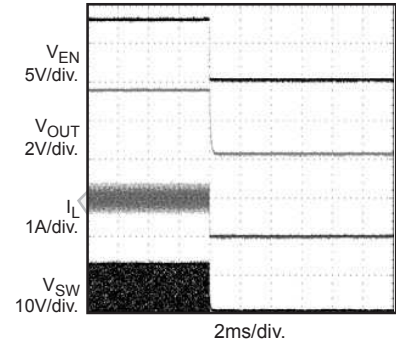

Heavy Load Operation

2A Load

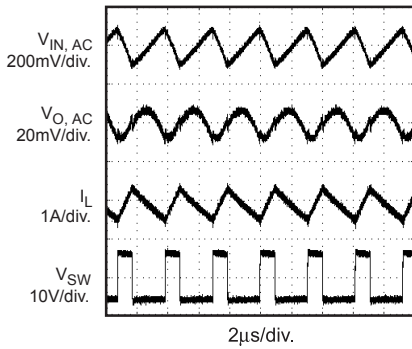

Medium Load Operation

1A Load

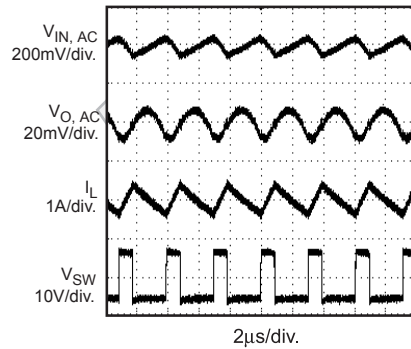

Light Load Operation

No Load

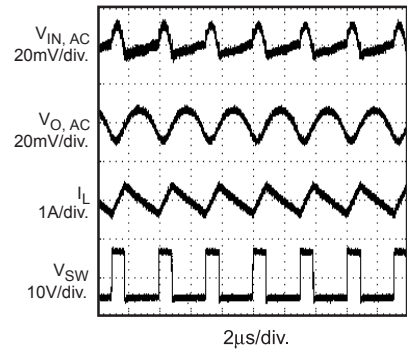

Short Circuit Protection

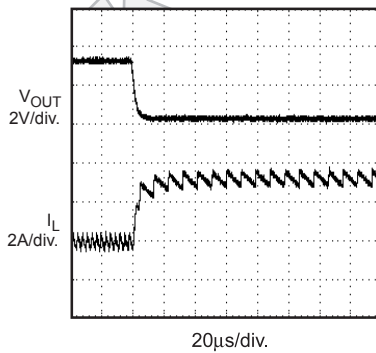

Short Circuit Recovery

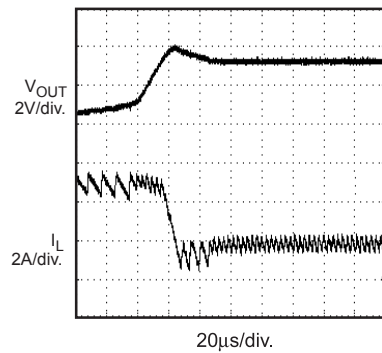

Load Transient

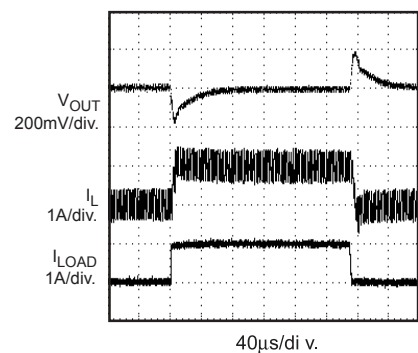

MP1482

TYPICAL APPLICATION CIRCUIT

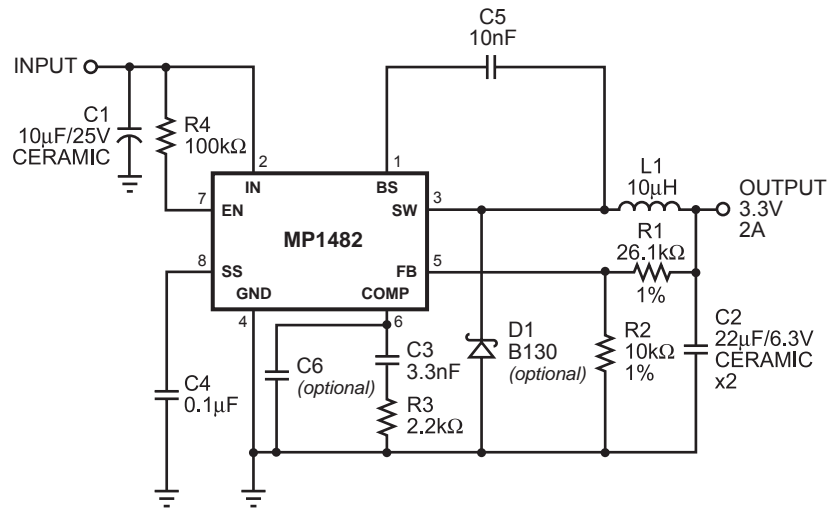

MP1482 with 3.3V Output, 22μF/6.3V Ceramic Output Capacitor