

Power Factor Controllers

MC34262

Features

- Overvoltage Comparator Eliminates Runaway Output Voltage
- Internal Startup Timer
- One Quadrant Multiplier
- Zero Current Detector
- Trimmed 2% Internal Bandgap Reference
- Totem Pole Output with High State Clamp
- Undervoltage Lockout with 6.0 V of Hysteresis
- Low Startup and Operating Current

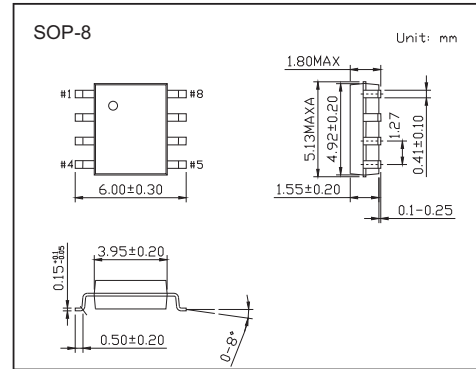

Functional Block Diagram

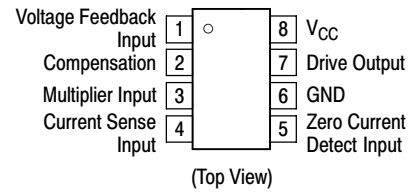
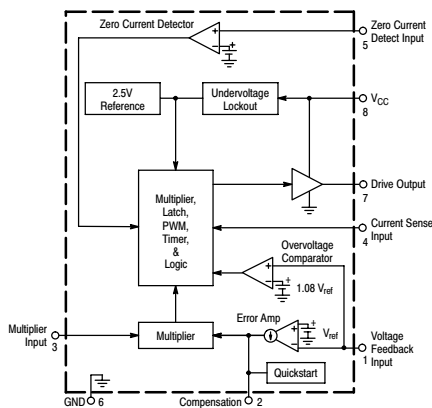

Absolute Maximum Ratings $T_a = 25^\circ\text{C}$

| Parameter | Symbol | Rating | Unit |
|--|------------------|-------------|---------------------------|
| Total Power Supply and Zener Current | $(I_{cc} + I_z)$ | 30 | mA |
| Output Current, Source or Sink (Note 1) | I_o | 500 | mA |
| Current Sense, Multiplier, and Voltage Feedback Inputs | V_{in} | -1.0 to +10 | V |
| Zero Current Detect Input High State Forward Current Low State Reverse Current | I_{in} | 50 -10 | mA |
| Power Dissipation @ $T_A = 70^\circ\text{C}$ | P_D | 450 | mW |
| Thermal Resistance, Junction to Air | $R_{\theta JA}$ | 178 | $^\circ\text{C}/\text{W}$ |
| Operating Junction Temperature | T_J | 150 | $^\circ\text{C}$ |
| Operating Ambient Temperature Range | T_A | 0 to +85 | $^\circ\text{C}$ |
| Storage Temperature Range | T_{stg} | -65 to +150 | $^\circ\text{C}$ |

NOTES: 1. Maximum package power dissipation limits must be observed.

MC34262

Electrical Characteristics ($V_{CC} = 12\text{ V}$ (Note 2), for typical values $T_A = 25^\circ\text{C}$, for min/max values T_A is the operating ambient temperature range that applies (Note 3), unless otherwise noted.)

| Parameter | Symbol | Test conditons | Min | Typ | Max | Unit |
|--|------------------------------|--|---------------------------------------|---------------------------------------|----------------|-----------------|
| Voltage Feedback Input Threshold $T_A = 25^\circ\text{C}$ $T_A = T_{\text{low}} \text{ to } T_{\text{high}}$ | V_{FB} | | 2.465 | 2.5 | 2.535 | V |
| | | $V_{CC} = 12\text{ V to } 28\text{ V}$ | 2.44 | | 2.54 | |
| Line Regulation | Reg_{line} | $V_{CC} = 12\text{ V to } 28\text{ V}$ | | 1.0 | 10 | mV |
| Input Bias Current | I_{IB} | $V_{FB} = 0\text{ V}$ | | -0.1 | -0.5 | μA |
| Transconductance | g_m | | 80 | 100 | 130 | μmho |
| Output Current ---Source ---Sink | I_O | $V_{FB} = 2.3\text{ V}$ $V_{FB} = 2.7\text{ V}$ | | 10 10 | | μA |
| Output Voltage Swing High State Low State | $V_{OH(ea)}$ $V_{OL(ea)}$ | $V_{FB} = 2.3\text{ V}$ $V_{FB} = 2.7\text{ V}$ | 5.8 | 6.4 1.7 | 2.4 | V |
| Voltage Feedback Input Threshold | $V_{FB(OV)}$ | | $1.065 V_{FB}$ | $1.08 V_{FB}$ | $1.095 V_{FB}$ | V |
| Input Threshold | $V_{th(M)}$ | | $1.05 V_{OL(EA)}$ | $1.05 V_{OL(EA)}$ | | V |
| Dynamic Input Voltage Range | | | | | | |
| Multiplier Input (Pin 3) | $V_{Pin 3}$ | | 0 to 2.5 | 0 to 3.5 | | V |
| Compensation (Pin 2) | $V_{Pin 2}$ | | $V_{th(M)}$ to $(V_{th(M)} + 1.0)$ | $V_{th(M)}$ to $(V_{th(M)} + 1.5)$ | | |
| Multiplier Gain (Note 4) | K | $V_{Pin 3} = 0.5\text{ V}, V_{Pin 2} = V_{th(M)} + 1.0\text{ V}$ | 0.43 | 0.65 | 0.87 | 1/V |
| ZERO CURRENT DETECTOR | | | | | | |
| Input Threshold Voltage (V_{in} Increasing) | V_{th} | | 1.3 | 1.6 | 1.87 | V |
| Hysteresis (V_{in} Decreasing) | V_H | | 100 | 200 | 300 | mV |
| Input Clamp Voltage High State Low State | V_{IH} V_{IL} | $I_{DET} = + 3.0\text{ mA}$ $I_{DET} = ? 3.0\text{ mA}$ | 6.1 0.3 | 6.7 0.7 | | V |
| CURRENT SENSE COMPARATOR | | | | | | |
| Input Bias Current | I_{IB} | $V_{Pin 4} = 0\text{ V}$ | | -0.15 | -1.0 | μA |
| Input Offset Voltage | | $V_{Pin 2} = 1.1\text{ V}, V_{Pin 3} = 0\text{ V}$ | | 9.0 | 25 | mV |
| Maximum Current Sense Input Threshold | $V_{th(max)}$ | $V_{FB} = 0\text{ V}, \text{ and } V_{Pin 3} = 3.0\text{ V}$ | 1.3 | 1.5 | 1.8 | |
| Delay to Output | $t_{PHL(in/out)}$ | | | 200 | 400 | ns |
| DRIVE OUTPUT | | | | | | |
| Output Voltage Low State High State | V_{OL} V_{OH} | $I_{Sink} = 20\text{ mA}$ $I_{Sink} = 200\text{ mA}$ $I_{Source} = 20\text{ mA}$ $I_{Source} = 200\text{ mA}$ | | 0.3 2.4 9.8 7.8 | 0.8 3.3 | V |
| Output Voltage --High State | $V_{O(max)}$ | $V_{CC} = 30\text{ V}, I_{Source} = 20\text{ mA},$ $C_L = 15\text{ pF}$ | 14 | 16 | 18 | V |
| Output Voltage Rise Time | t_r | $C_L = 1.0\text{ nF}$ | | 50 | 120 | ns |
| Output Voltage Fall Time | t_f | $C_L = 1.0\text{ nF}$ | | 50 | 120 | ns |
| Output Voltage with UVLO Activated | $V_{O(UVLO)}$ | $V_{CC} = 7.0\text{ V}, I_{Sink} = 1.0\text{ mA}$ | | 0.1 | 0.5 | V |

MC34262

Electrical Characteristics (V_{CC} = 12 V (Note 2), for typical values T_A = 25°C, for min/max values T_A is the operating ambient temperature range that applies (Note 3), unless otherwise noted.)

| RESTART TIMER | | | | | | | |
|--|-----------------------|-------------------------|---------------------------------|-------------------------|------|----|-----|
| Restart Time Delay | tdLY | | 200 | 600 | | μs | |
| UNDERVOLTAGE LOCKOUT | | | | | | | |
| Startup Threshold (V _{CC} Increasing) | V _{th(on)} | | 11.5 | 13 | 14.5 | V | |
| Minimum Operating Voltage After Turn?On (V _{CC} Decreasing) | V _{Shutdown} | | 7.0 | 8.0 | 9.0 | V | |
| V _{Shutdown} | V _H | | 3.8 | 5.0 | 6.2 | V | |
| TOTAL DEVICE | | | | | | | |
| Power Supply Current | I _{CC} | V _{CC} = 7.0 V | 50 kHz, C _L = 1.0 nF | I _{CC} = 25 mA | | mA | |
| Startup | | | | | 0.25 | | 0.4 |
| Operating | | | | | 6.5 | | 12 |
| Dynamic Operating | | | 9 | 20 | | | |
| Power Supply Zener Voltage | V _Z | | 30 | 36 | | V | |

NOTES: 2.Adjust V_{CC} above the startup threshold before setting to 12 V.

3.T_{low} = 0°C, T_{high} = +85°C.

4. $K = \text{Pin 4 Threshold} / (V_{\text{Pin 3}} - V_{\text{th(M)}})$

Typical Characteristics

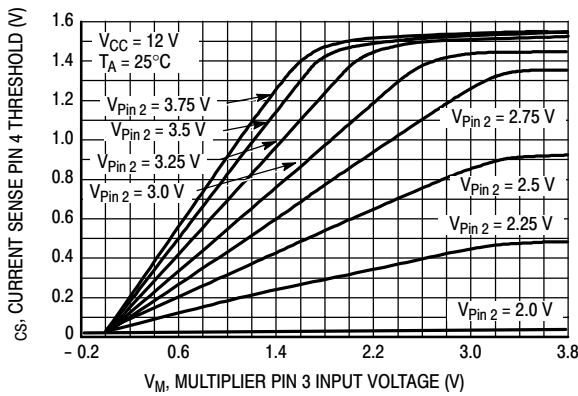

Figure 3. Current Sense Input Threshold versus Multiplier Input

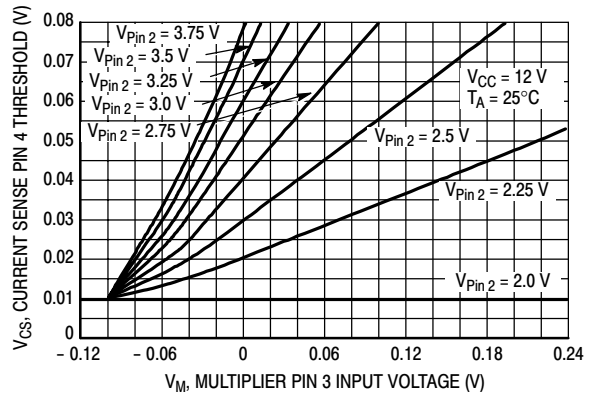

Figure 4. Current Sense Input Threshold versus Multiplier Input, Expanded View

MC34262

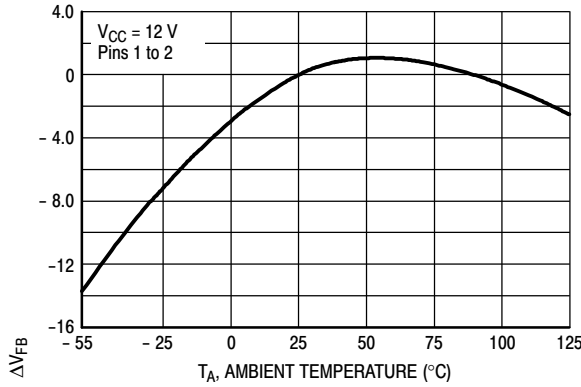

Figure 3. Voltage Feedback Input Threshold Change versus Temperature

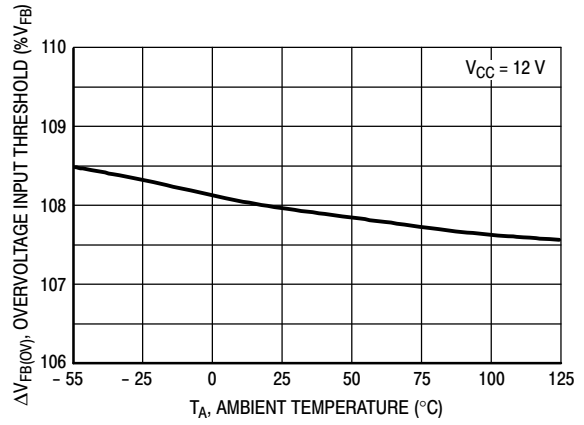

Figure 4. Overvoltage Comparator Input Threshold versus Temperature

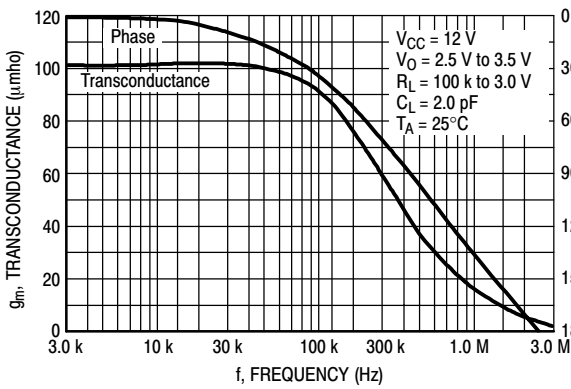

Figure 5. Error Amp Transconductance and Phase versus Frequency

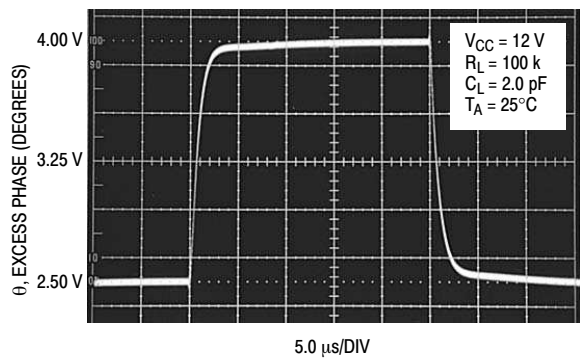

Figure 6. Error Amp Transient Response

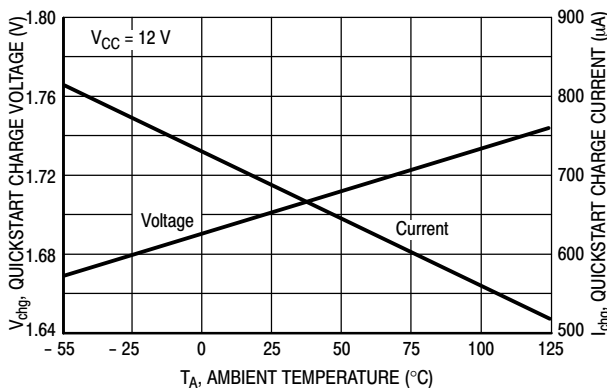

Figure 7. Quickstart Charge Current versus Temperature

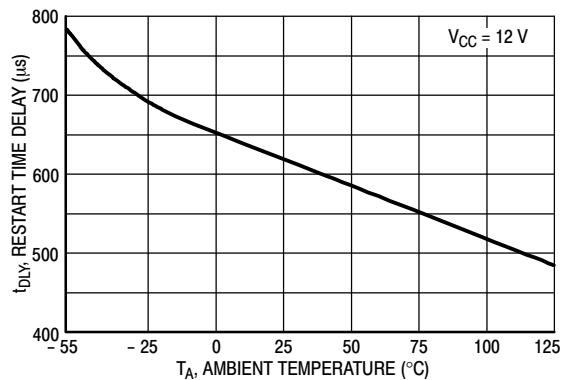

Figure 8. Restart Timer Delay versus Temperature

MC34262

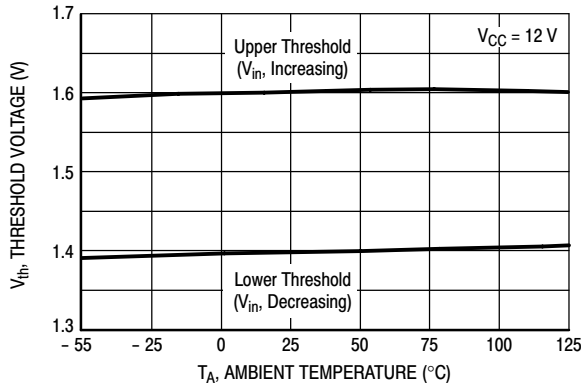

Figure 9. Zero Current Detector Input Threshold Voltage versus Temperature

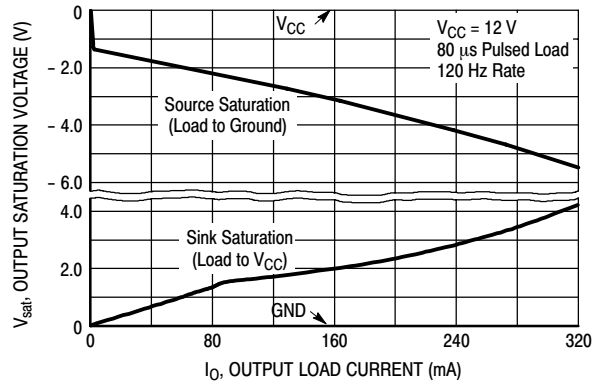

Figure 10. Output Saturation Voltage versus Load Current

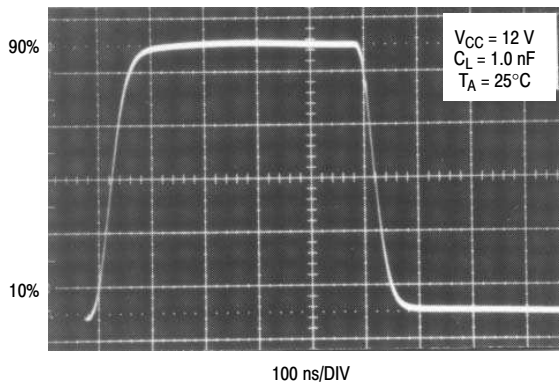

Figure 11. Drive Output Waveform

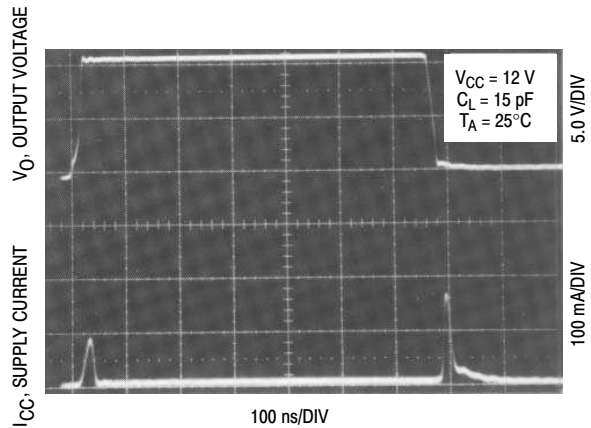

Figure 12. Drive Output Cross Conduction

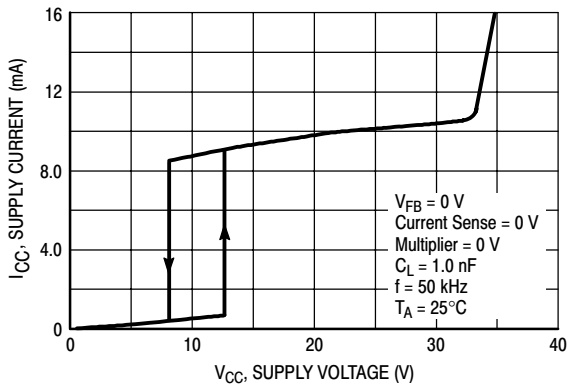

Figure 13. Supply Current versus Supply Voltage

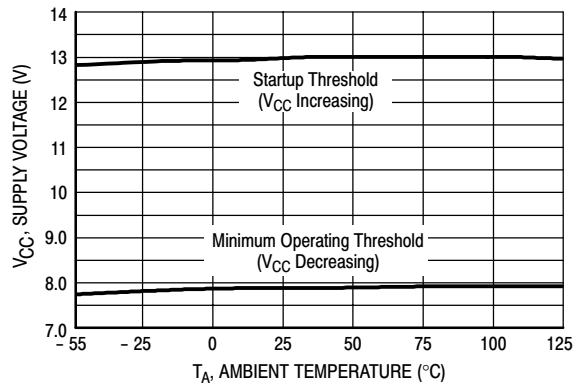

Figure 14. Undervoltage Lockout Thresholds versus Temperature

MC34262

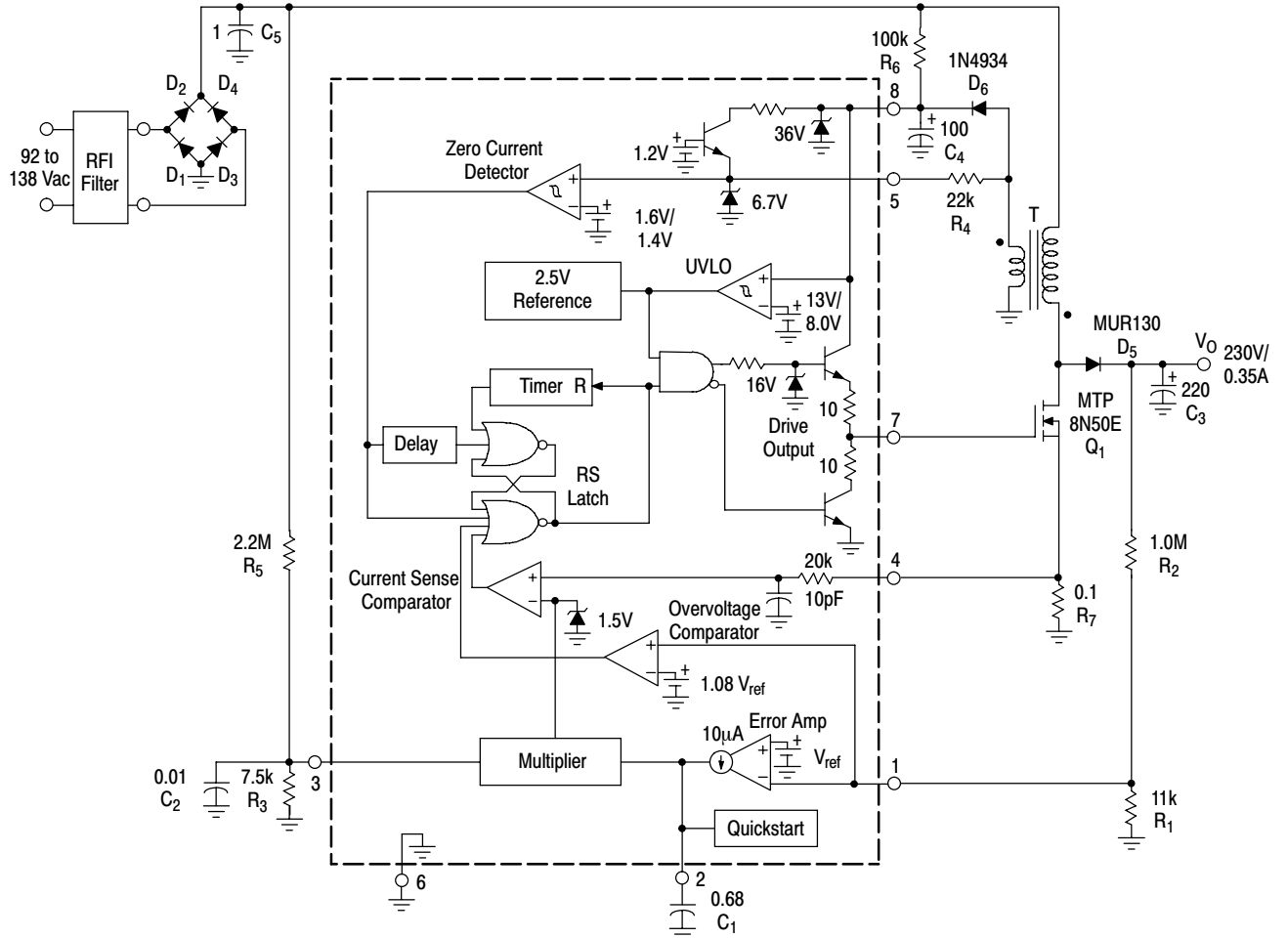

Figure 15. 80 W Power Factor Controller

MC34262

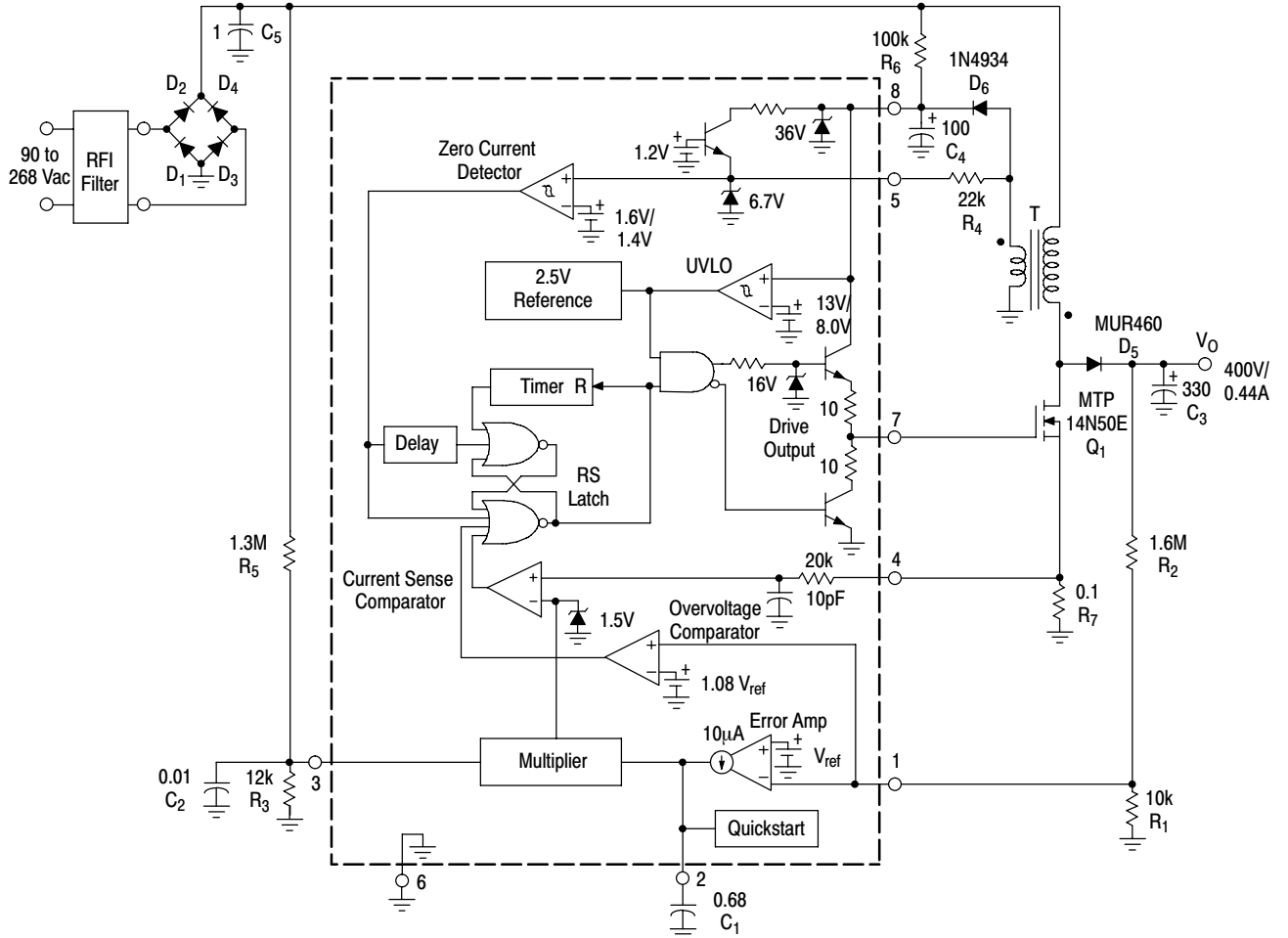

Figure 16. 175 W Universal Input Power Factor Controller

MC34262

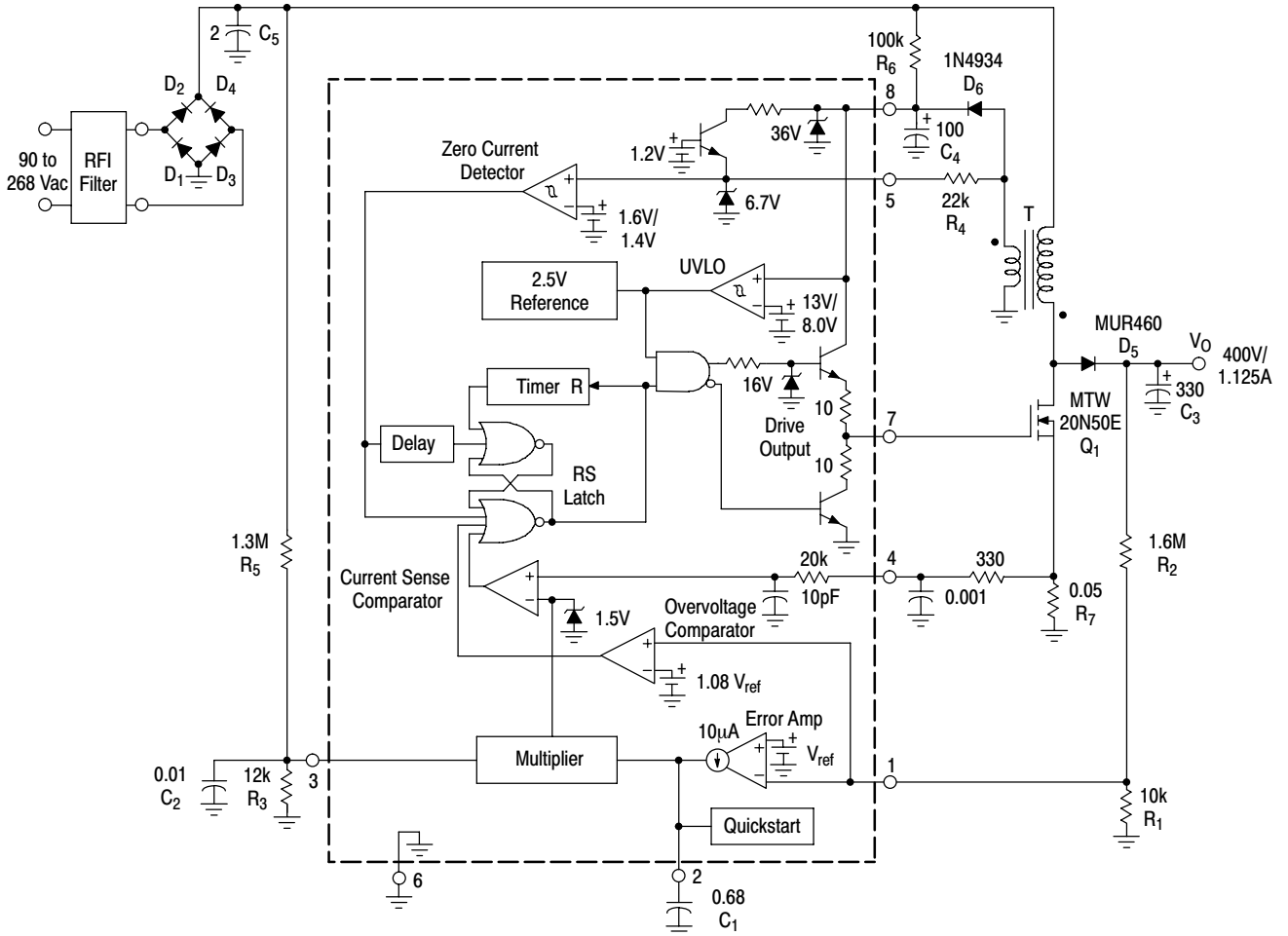

Figure 17. 450 W Universal Input Power Factor Controller