

TrenchMOS™ standard level FET

KUK7109-75ATE

■ Features

- Integrated temperature sensor
- Electrostatic discharge protection
- Q101 compliant
- Standard level compatible.

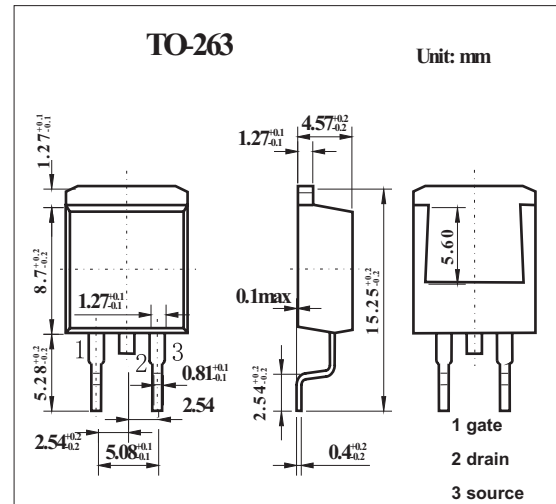
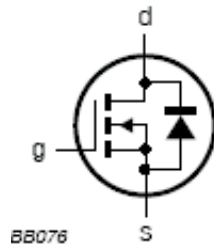

■ Absolute Maximum Ratings $T_a = 25^\circ\text{C}$

Parameter	Symbol	Rating	Unit
Drain-source voltage	V_{DS}	75	V
Drain-gate voltage $R_{GS} = 20\text{ K}\Omega$	V_{DGR}	75	V
Gate-source voltage	V_{GS}	± 20	V
Drain current (DC) $T_{mb} = 25^\circ\text{C}, V_{GS} = 10\text{ V}$	I_D	120	A
Drain current (DC) $T_{mb} = 100^\circ\text{C}, V_{GS} = 10\text{ V}$	I_D	75	A
Drain current (pulse peak value) *1	I_{DM}	480	A
Total power dissipation $T_{mb} = 25^\circ\text{C}$	P_{tot}	272	W
gate-source clamping current (continuous)	$I_{GS(CL)}$	10	mA
gate-source clamping current *3		50	mA
FET to temperature sense diode isolation voltage	$V_{isol}(FET-TSD)$	± 100	V
Storage & operating temperature	T_{stg}, T_j	-55 to 175	$^\circ\text{C}$
reverse drain current (DC) $T_{mb} = 25^\circ\text{C}$	I_{DR}	120	A
		75	A
pulsed reverse drain current *1	I_{DRM}	480	A
non-repetitive avalanche energy *2	$E_{DS(AL)S}$	739	J
Thermal resistance junction to mounting base	$R_{th\ j-mb}$	0.55	K/W
Thermal resistance junction to ambient	$R_{th\ j-a}$	50	K/W

* 1 $T_{mb} = 25^\circ\text{C}$; pulsed; $t_p \leq 10\ \mu\text{s}$;

* 2 unclamped inductive load; $I_D = 75\text{ A}; V_{DS} \leq 75\text{ V}; V_{GS} = 10\text{ V}; R_{GS} = 50\Omega$; starting $T_j = 25^\circ\text{C}$

* 3 $t_p = 5\text{ ms}; \delta = 0.01$

KUK7109-75ATE

■ Electrical Characteristics Ta = 25°C

Parameter	Symbol	Testconditions	Min	Typ	Max	Unit
drain-source breakdown voltage	V _{(BR)DSS}	I _D = 0.25 mA; V _{GS} = 0 V; T _J = 25°C	75			V
		I _D = 0.25 mA; V _{GS} = 0 V; T _J = -55°C	70			V
gate-source threshold voltage	V _{GS(th)}	I _D = 1 mA; V _{DS} = V _{GS} ; T _J = 25°C	2	3	4	V
		I _D = 1 mA; V _{DS} = V _{GS} ; T _J = 175°C	1			V
		I _D = 1 mA; V _{DS} = V _{GS} ; T _J = -55°C			4.4	V
Zero gate voltage drain current	I _{DSS}	V _{DS} = 75 V; V _{GS} = 0 V; T _J = 25°C		0.1	10	μA
		V _{DS} = 75 V; V _{GS} = 0 V; T _J = 175°C			250	μA
gate-source breakdown voltage	V _{(BR)GSS}	I _G = ±1 mA; -55°C < T _J < 175°C	20	22		
gate-source leakage current	I _{GSS}	V _{GS} = ±10 V; V _{DS} = 0 V; T _J = 25°C		22	1000	nA
		V _{GS} = ±10 V; V _{DS} = 0 V; T _J = 175°C			10	μA
drain-source on-state resistance	R _{DS(on)}	V _{GS} = 10 V; I _D = 50 A; T _J = 25°C	.	8	9	mΩ
		V _{GS} = 10 V; I _D = 50 A; T _J = 175°C			19	mΩ
forward voltage; temperature sense diode	V _F	I _F = 250 mA	648	658	668	mV
temperature coefficient temperature sense diode	S _F	I _F = 250 mA; -55°C < T _J < 175°C	-1.4	-1.54	-1.68	mV/K
temperature sense diode forward voltage hysteresis	V _{hys}	125 mA < I _F < 250 mA	25	32	50	mV
total gate charge	Q _{g(tot)}	V _{GS} = 10 V; V _{DD} = 60 V; I _D = 25 A		121		nC
gate-to-source charge	Q _{gs}		20		nC	
gate-to-drain (Miller) charge	Q _{gd}		44		nC	
input capacitance	C _{iss}	V _{GS} = 0 V; V _{DS} = 25 V; f = 1 MHz		4700	3760	pF
output capacitance	C _{oss}			800	665	pF
reverse transfer capacitance	C _{rss}			455	274	pF
turn-on delay time	t _{d(on)}	V _{DD} = 30 V; R _L = 1.2Ω; V _{GS} = 10 V; R _G = 10Ω		35		ns
rise time	t _r			108		ns
turn-off delay time	t _{d(off)}			185		ns
fall time	t _f			100		ns
internal drain inductance	L _d	measured from upper edge of drain mounting base to center of die		2.5		nH
internal source inductance	L _s	measured from source lead to source bond pad		7.5		nH
source-drain (diode forward) voltage	V _{SD}	I _S = 25A; V _{GS} = 0 V		0.85	1.2	V
reverse recovery time	t _{rr}	I _S = 20 A; -di _F /dt = -100 A/μs;		75		ns
recovered charge	Q _r	V _{GS} = -10 V; V _{DS} = 30 V		270		nC