

TrenchPLUS standard level FET

KUK7105-40AIE

■ Features

- Integrated temperature sensor
- Electrostatic discharge protection
- Q101 compliant
- Standard level compatible.

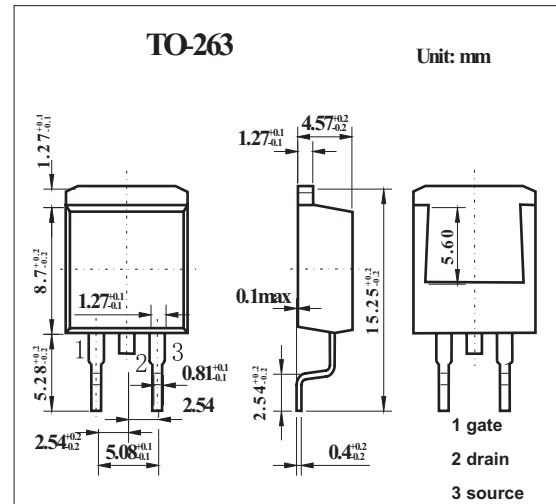

■ Absolute Maximum Ratings $T_a = 25^\circ\text{C}$

Parameter	Symbol	Rating	Unit
Drain-source voltage	V_{DS}	40	V
Drain-gate voltage $R_{GS} = 20\text{ K}\Omega$	V_{DGS}	40	V
Gate-source voltage	V_{GS}	± 20	V
Drain current (DC) $T_{mb} = 25^\circ\text{C}, V_{GS} = 10\text{ V}$	I_D	155	A
Drain current (DC) $T_{mb} = 100^\circ\text{C}, V_{GS} = 10\text{ V}$	I_D	75	A
peak drain current *1	I_{DM}	620	A
Total power dissipation $T_{mb} = 25^\circ\text{C}$	P_{tot}	272	W
gate-source clamping current (continuous)	$I_{GS(CL)}$	10	mA
gate-source clamping current *3		50	mA
Storage & operating temperature	T_{stg}, T_j	-55 to 175	$^\circ\text{C}$
reverse drain current (DC) $T_{mb} = 25^\circ\text{C}$	I_{DR}	155	A
		75	A
pulsed reverse drain current *1	I_{DRM}	620	A
non-repetitive avalanche energy *2	$EDS(AL)S$	1.46	J
Thermal resistance junction to mounting base	$R_{th\ j-mb}$	0.55	K/W
Thermal resistance junction to ambient	$R_{th\ j-a}$	50	K/W

*1 $T_{mb} = 25^\circ\text{C}$; pulsed; $t_p \leq 10\ \mu\text{s}$;

*2 unclamped inductive load; $I_D = 75\text{ A}$; $V_{DS} \leq 40\text{ V}$; $V_{GS} = 10\text{ V}$; $R_{GS} = 50\Omega$; starting $T_j = 25^\circ\text{C}$

*3 $t_p = 5\text{ ms}$; $\delta = 0.01$

KUK7105-40AIE

■ Electrical Characteristics Ta = 25°C

Parameter	Symbol	Testconditions	Min	Typ	Max	Unit
drain-source breakdown voltage	V _{(BR)DSS}	I _D = 0.25 mA; V _{GS} = 0 V; T _J = 25°C	40			V
		I _D = 0.25 mA; V _{GS} = 0 V; T _J = -55°C	36			V
gate-source threshold voltage	V _{GS(th)}	I _D = 1 mA; V _{DS} = V _{GS} ; T _J = 25°C	2	3	4	V
		I _D = 1 mA; V _{DS} = V _{GS} ; T _J = 175°C	1			V
		I _D = 1 mA; V _{DS} = V _{GS} ; T _J = -55°C			4.4	V
Zero gate voltage drain current	I _{DSS}	V _{DS} = 40 V; V _{GS} = 0 V; T _J = 25°C		0.1	10	μA
		V _{DS} = 40 V; V _{GS} = 0 V; T _J = 175°C			250	μA
gate-source breakdown voltage	V _{(BR)GSS}	I _G = ±1 mA; -55°C < T _J < 175°C	20	22		V
gate-source leakage current	I _{GSS}	V _{GS} = ±10 V; V _{DS} = 0 V; T _J = 25°C		22	1000	nA
		V _{GS} = ±10 V; V _{DS} = 0 V; T _J = 175°C			10	μA
drain-source on-state resistance	R _{DS(on)}	V _{GS} = 10 V; I _D = 50 A; T _J = 25°C	.	4.5	5	mΩ
		V _{GS} = 10 V; I _D = 50 A; T _J = 175°C			9.5	mΩ
drain-Isense on-state resistance	R _{D(Is)on}	V _{GS} = 10 V; I _D = 100 mA; T _J = 25°C	0.98	1.08	1.18	Ω
		V _{GS} = 10 V; I _D = 100 mA; T _J = 175°C	1.86	2.05	2.24	Ω
ratio of drain current to sense current	I _D /I _{sense}	V _{GS} > 10 V; -55°C < T _J < 175°C	450	500	550	
total gate charge	Q _{g(tot)}	V _{GS} = 10 V; V _{DD} = 32 V; I _D = 25 A		120	127	nC
gate-to-source charge	Q _{gs}			19	22	nC
gate-to-drain (Miller) charge	Q _{gd}			50	60	nC
input capacitance	C _{iss}	V _{GS} = 0 V; V _{DS} = 25 V; f = 1 MHz		4300	5000	pF
output capacitance	C _{oss}			1400	1670	pF
reverse transfer capacitance	C _{rss}			820	1100	pF
turn-on delay time	t _{d(on)}			35		ns
rise time	t _r	V _{DD} = 30 V; R _L = 1.2Ω; V _{GS} = 10 V; R _G = 10Ω		115		ns
turn-off delay time	t _{d(off)}			155		ns
fall time	t _f			110		ns
internal drain inductance	L _d	measured from upper edge of drain mounting base to center of die		2.5		nH
internal source inductance	L _s	measured from source lead to source bond pad		7.5		nH
source-drain (diode forward) voltage	V _{SD}	I _s = 25A; V _{GS} = 0 V		0.85	1.2	V
reverse recovery time	t _{rr}	I _s = 20 A; diF/dt = -100 A/μs;		96		ns
recovered charge	Q _r	V _{GS} = -10 V; V _{DS} = 30 V		224		nC