

# HEXFET<sup>®</sup> Power MOSFET

## KRF4905S

### ■ Features

- Advanced Process Technology
- Surface Mount
- 175°C Operating Temperature
- Fast Switching
- P-Channel
- Fully Avalanche Rated

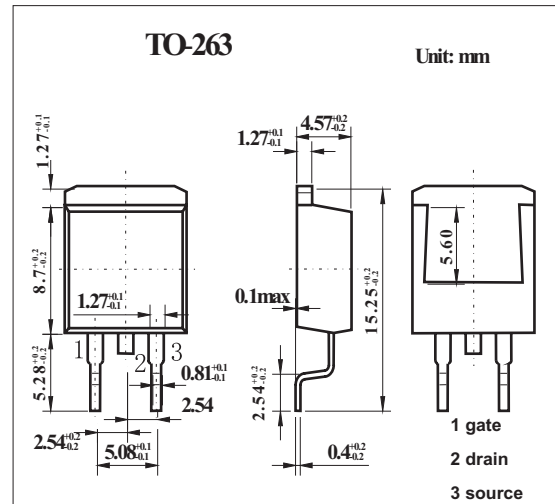
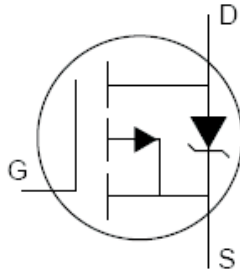

### ■ Absolute Maximum Ratings Ta = 25°C

Parameter	Symbol	Rating	Unit
Continuous Drain Current, V <sub>GS</sub> @ -10V, T <sub>c</sub> = 25°C	I <sub>D</sub>	-74	A
Continuous Drain Current, V <sub>GS</sub> @ -10V, T <sub>c</sub> = 100°C	I <sub>D</sub>	-52	
Pulsed Drain Current*1	I <sub>DM</sub>	-260	
Power Dissipation Ta = 25°C	P <sub>D</sub>	3.8	W
Power Dissipation Tc = 25°C		200	
Linear Derating Factor		1.3	W/°C
Gate-to-Source Voltage	V <sub>GS</sub>	±20	V
Single Pulse Avalanche Energy*4	E <sub>AS</sub>	930	mJ
Avalanche Current *1	I <sub>AR</sub>	-38	A
Repetitive Avalanche Energy	E <sub>AR</sub>	20	mJ
Peak Diode Recovery dv/dt *2	dv/dt	-5	V/ns
Operating Junction and Storage Temperature Range	T <sub>J</sub> , T <sub>STG</sub>	-55 to + 175	°C
Junction-to-Case	R <sub>θJC</sub>	0.75	°C/W
Junction-to-Ambient	R <sub>θJA</sub>	40	°C/W

\*1 Repetitive rating; pulse width limited by max. junction temperature.

\*2 I<sub>SD</sub> ≤ -38A, di/dt ≤ -270A/μs, V<sub>DD</sub> ≤ V<sub>(BR)DSS</sub>, T<sub>J</sub> ≤ 175°C

\*3 When mounted on 1" square PCB

\*4 Starting T<sub>J</sub> = 25°C, L = 1.3mH, R<sub>G</sub> = 25Ω, I<sub>AS</sub> = -38A.

## KRF4905S

## ■ Electrical Characteristics Ta = 25°C

Parameter	Symbol	Testconditions	Min	Typ	Max	Unit
Drain-to-Source Breakdown Voltage	$V_{(BR)DSS}$	$V_{GS} = 0V, I_D = -250 \mu A$	-55			V
Breakdown Voltage Temp. Coefficient	$\Delta V_{(BR)DSS}/\Delta T_J$	$I_D = -1mA, \text{Reference to } 25^\circ C$		-0.05		V/°C
Static Drain-to-Source On-Resistance	$R_{DS(on)}$	$V_{GS} = -10V, I_D = -38A^{*1}$			0.02	mΩ
Gate Threshold Voltage	$V_{GS(th)}$	$V_{DS} = V_{GS}, I_D = -250 \mu A$	-2.0		-4	V
Forward Transconductance	$g_{fs}$	$V_{DS} = -25V, I_D = -38A^{*1}$	21			S
Drain-to-Source Leakage Current	$I_{DSS}$	$V_{DS} = -55V, V_{GS} = 0V$			-25	μA
		$V_{DS} = -44V, V_{GS} = 0V, T_J = 150^\circ C$			-250	
Gate-to-Source Forward Leakage	$I_{GSS}$	$V_{GS} = 20V$			100	nA
Gate-to-Source Reverse Leakage		$V_{GS} = -20V$			-100	
Total Gate Charge	$Q_g$	$I_D = -38A$			180	nC
Gate-to-Source Charge	$Q_{gs}$	$V_{DS} = -44V$			32	
Gate-to-Drain ("Miller") Charge	$Q_{gd}$	$V_{GS} = -10V,^{*1}$			86	
Turn-On Delay Time	$t_{d(on)}$	$V_{DD} = -28V$		18		ns
Rise Time	$t_r$	$I_D = -38A$		99		
Turn-Off Delay Time	$t_{d(off)}$	$R_G = 2.5 \Omega$		61		
Fall Time	$t_f$	$R_D = 0.72 \Omega^{*1}$		96		
Internal Source Inductance	$L_S$	Between lead, and center of die contact		7.5		nH
Input Capacitance	$C_{iss}$	$V_{GS} = 0V$		3400		pF
Output Capacitance	$C_{oss}$	$V_{DS} = -25V$		1400		
Reverse Transfer Capacitance	$C_{rss}$	$f = 1.0MHz$		640		
Continuous Source Current (Body Diode)	$I_S$	MOSFET symbol showing the integral reverse p-n junction diode. 			-74	A
Pulsed Source Current (Body Diode) *2	$I_{SM}$				-260	
Diode Forward Voltage	$V_{SD}$	$T_J = 25^\circ C, I_S = -38A, V_{GS} = 0V^{*1}$			-1.6	V
Reverse Recovery Time	$t_{rr}$	$T_J = 25^\circ C, I_F = -38A$		89	130	ns
Reverse Recovery Charge	$Q_{rr}$	$di/dt = 100A/\mu s^{*1}$		230	350	nC
Forward Turn-On Time	$t_{on}$	Intrinsic turn-on time is negligible (turn-on is dominated by $L_S+L_D$ )				

\*1 Pulse width  $\leq 300 \mu s$ ; duty cycle  $\leq 2\%$ .

\*2 Repetitive rating; pulse width limited by max